

cell-based assays to evaluate 2-(2-Bromophenyl)morpholine activity

Author: BenchChem Technical Support Team. **Date:** May 2026

Compound of Interest

Compound Name: 2-(2-Bromophenyl)morpholine

CAS No.: 1097796-83-2

Cat. No.: B1289296

[Get Quote](#)

An Application Note and Protocols for the Cellular Evaluation of **2-(2-Bromophenyl)morpholine**

Abstract

This document provides a comprehensive guide for researchers, scientists, and drug development professionals on the characterization of **2-(2-Bromophenyl)morpholine** using a suite of robust, cell-based assays. The morpholine scaffold is a privileged structure in medicinal chemistry, frequently associated with neurological activity.^{[1][2][3]} This guide outlines a logical, multi-step experimental workflow designed to first identify the primary molecular targets of the compound and then to characterize its downstream functional consequences and potential cytotoxic effects. We provide detailed, field-proven protocols for monoamine transporter uptake inhibition assays, secondary messenger signaling assays, and general cell viability assessments, grounded in authoritative scientific principles.

Introduction: The Pharmacological Potential of the Morpholine Scaffold

The morpholine ring is a versatile heterocyclic motif present in numerous approved drugs and clinical candidates, known to confer favorable pharmacokinetic properties and potent biological activity.[2][3] Many morpholine derivatives interact with targets in the central nervous system (CNS), including monoamine transporters and G-protein coupled receptors (GPCRs).[1][4] **2-(2-Bromophenyl)morpholine**, a specific analog, warrants systematic investigation to elucidate its mechanism of action and therapeutic potential.

Cell-based assays are indispensable tools in this process, offering a biologically relevant environment to study a compound's effect on specific molecular targets and pathways within a living system.[5] Unlike simpler biochemical assays, they provide integrated data on compound permeability, target engagement, and immediate cellular response. This application note details a strategic approach to systematically deconstruct the pharmacological profile of **2-(2-Bromophenyl)morpholine**.

Hypothesized Mechanism of Action and Strategic Workflow

Based on its structural similarity to known psychoactive agents, the primary hypothesis is that **2-(2-Bromophenyl)morpholine** functions as an inhibitor of monoamine transporters—specifically the dopamine (DAT), norepinephrine (NET), and serotonin (SERT) transporters.[1] These transporters are critical for regulating neurotransmission by clearing their respective neurotransmitters from the synaptic cleft.[6][7][8] Inhibition of this reuptake process increases the concentration and duration of neurotransmitters in the synapse, a mechanism shared by many antidepressants and psychostimulants.[9][10]

Our proposed workflow is designed to test this hypothesis rigorously and build a comprehensive pharmacological profile.

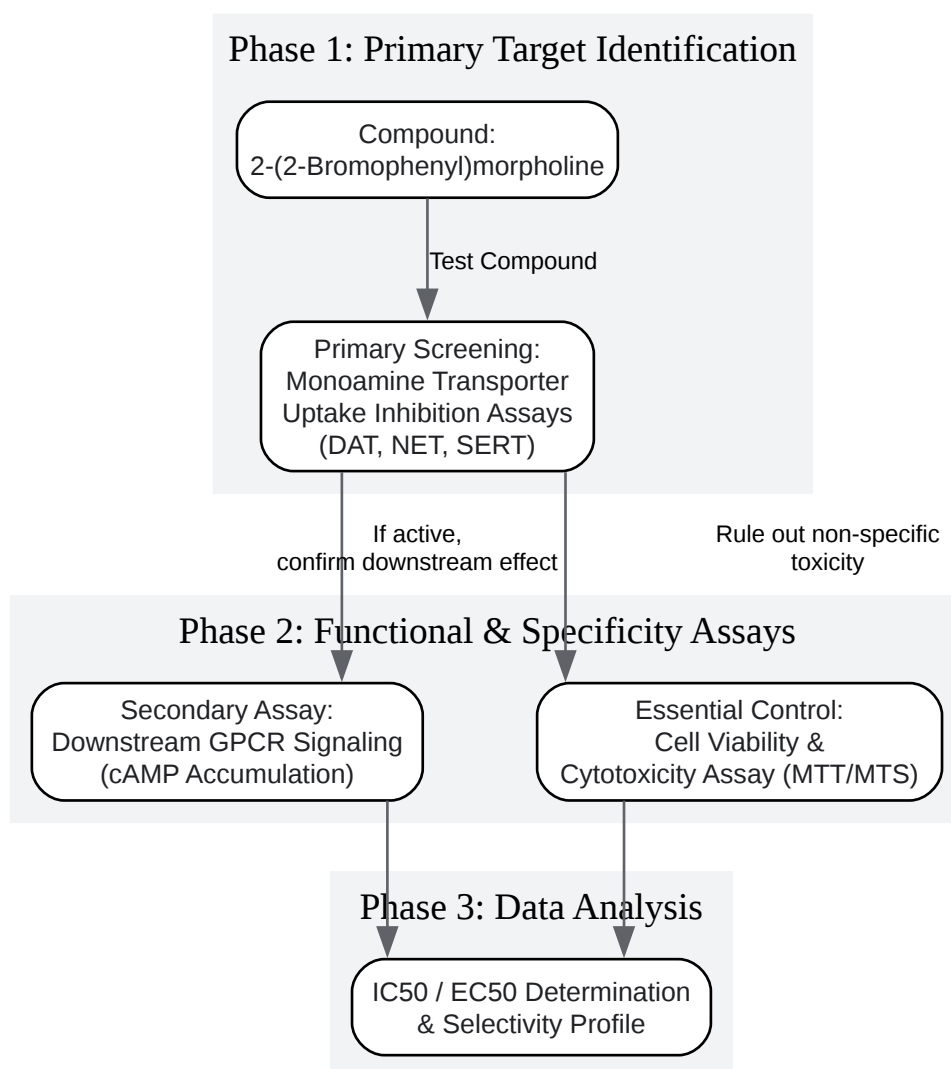

[Click to download full resolution via product page](#)

Caption: Experimental workflow for characterizing **2-(2-Bromophenyl)morpholine**.

Primary Target Identification: Monoamine Transporter Uptake Assays

The foundational experiment is to determine if **2-(2-Bromophenyl)morpholine** inhibits the function of the primary monoamine transporters. This is achieved by measuring the uptake of a labeled substrate (either radioactive or fluorescent) into cells engineered to express a single human transporter type (hDAT, hNET, or hSERT).[5][11] Using single-transporter cell lines, such as HEK293, is critical for unambiguously assigning activity to a specific target.[5]

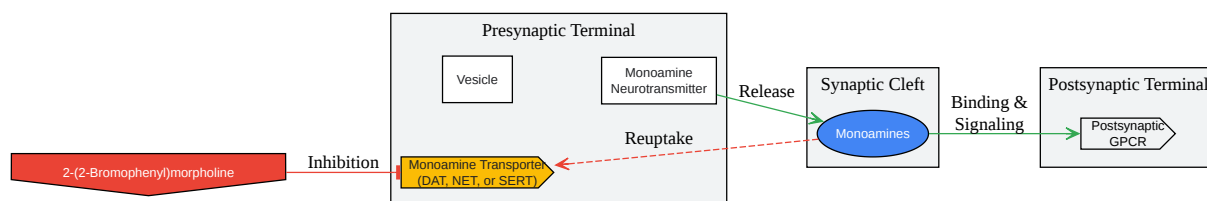

[Click to download full resolution via product page](#)

Caption: Hypothesized inhibition of monoamine reuptake at the synapse.

Protocol 3.1: Neurotransmitter Uptake Inhibition Assay (Fluorescent Method)

This protocol is adapted from methodologies using commercially available kits which employ a fluorescent substrate that mimics biogenic amines.[12][13][14] It offers a non-radioactive, high-throughput alternative for measuring transporter activity.[12]

Materials:

- Cell Lines: HEK293 cells stably expressing hDAT, hNET, or hSERT (e.g., from ATCC or other commercial vendors).
- Culture Medium: DMEM, 10% Fetal Bovine Serum (FBS), 1% Penicillin-Streptomycin, and a selection antibiotic (e.g., G418). Note: Some protocols recommend dialyzed FBS for hSERT cells.[13]
- Assay Plate: Black, clear-bottom 96-well microplates.
- Reagents: Neurotransmitter Transporter Uptake Assay Kit (e.g., from Molecular Devices), containing a fluorescent substrate and a masking dye to quench extracellular fluorescence. [14]

- Test Compound: **2-(2-Bromophenyl)morpholine**, dissolved in DMSO to create a 10 mM stock.
- Control Inhibitors: Nomifensine (for DAT), Nisoxetine or Desipramine (for NET), and Fluoxetine or Imipramine (for SERT).[\[10\]](#)[\[15\]](#)[\[16\]](#)

Procedure:

- Cell Plating:
 - The day before the assay, seed the cells into a 96-well plate at a density of 40,000–60,000 cells per well in 100 μ L of culture medium.[\[13\]](#)
 - Incubate overnight (18-24 hours) at 37°C, 5% CO₂ to allow for the formation of a confluent monolayer.[\[13\]](#)
- Compound Preparation:
 - Prepare serial dilutions of **2-(2-Bromophenyl)morpholine** in assay buffer (provided in the kit or a simple Krebs-Ringer-HEPES buffer). A typical concentration range would be from 10 pM to 100 μ M.
 - Prepare solutions for controls:
 - Maximum Uptake (Vehicle Control): Assay buffer with DMSO, matching the final concentration in the test wells.
 - Positive Control (Known Inhibitor): A concentration of the known inhibitor sufficient to cause >90% inhibition (e.g., 10 μ M Nomifensine for DAT).
 - No-Transporter Control: Use non-transfected HEK293 cells to measure background fluorescence.
- Assay Execution:
 - On the day of the assay, gently remove the culture medium from the wells.
 - Wash the cell monolayer once with 100 μ L of pre-warmed assay buffer.

- Add 50 μ L of the diluted test compound, vehicle, or positive control inhibitor to the appropriate wells.
- Pre-incubate the plate for 10-20 minutes at 37°C.[10][15]
- Prepare the fluorescent substrate working solution according to the kit manufacturer's instructions (typically includes the substrate and a masking dye).
- Initiate the uptake by adding 50 μ L of the substrate working solution to all wells.
- Immediately transfer the plate to a bottom-reading fluorescent plate reader pre-set to 37°C.
- Data Acquisition:
 - Measure the fluorescence intensity over time (kinetic mode) for 10-20 minutes or as a single endpoint reading after a fixed incubation period (e.g., 15 minutes).[10][14] Use excitation/emission wavelengths appropriate for the specific fluorescent substrate.

Data Analysis and Presentation

The rate of substrate uptake is determined from the slope of the kinetic read or the endpoint fluorescence value.

- Normalization: Normalize the data by expressing the fluorescence in each well as a percentage of the vehicle control (100% activity) after subtracting the background (no-transporter control).
- IC₅₀ Calculation: Plot the normalized percent inhibition against the logarithm of the compound concentration. Fit the data using a four-parameter logistic (sigmoidal dose-response) curve to determine the IC₅₀ value.

Table 1: Hypothetical Transporter Inhibition Data for **2-(2-Bromophenyl)morpholine**

Transporter Target	IC ₅₀ (nM)	95% Confidence Interval	n	Positive Control	Positive Control IC ₅₀ (nM)
hDAT	85.2	75.1 - 96.5	3	Nomifensine	4.8
hNET	15.6	12.9 - 18.8	3	Nisoxetine	1.1
hSERT	1250.4	1089.2 - 1435.6	3	Fluoxetine	2.5

This data suggests the compound is a potent and selective inhibitor of the norepinephrine transporter (NET) over DAT and SERT.

Downstream Functional Confirmation: cAMP Signaling Assay

If **2-(2-Bromophenyl)morpholine** inhibits NET, it will increase extracellular norepinephrine. Norepinephrine primarily signals through adrenergic receptors, many of which are GPCRs that modulate the production of the second messenger cyclic AMP (cAMP).^[7] For example, activation of β -adrenergic receptors stimulates adenylyl cyclase via a G_s protein, increasing cAMP levels. A cAMP assay can therefore serve as a functional confirmation of the compound's downstream biological effect.^{[17][18]}

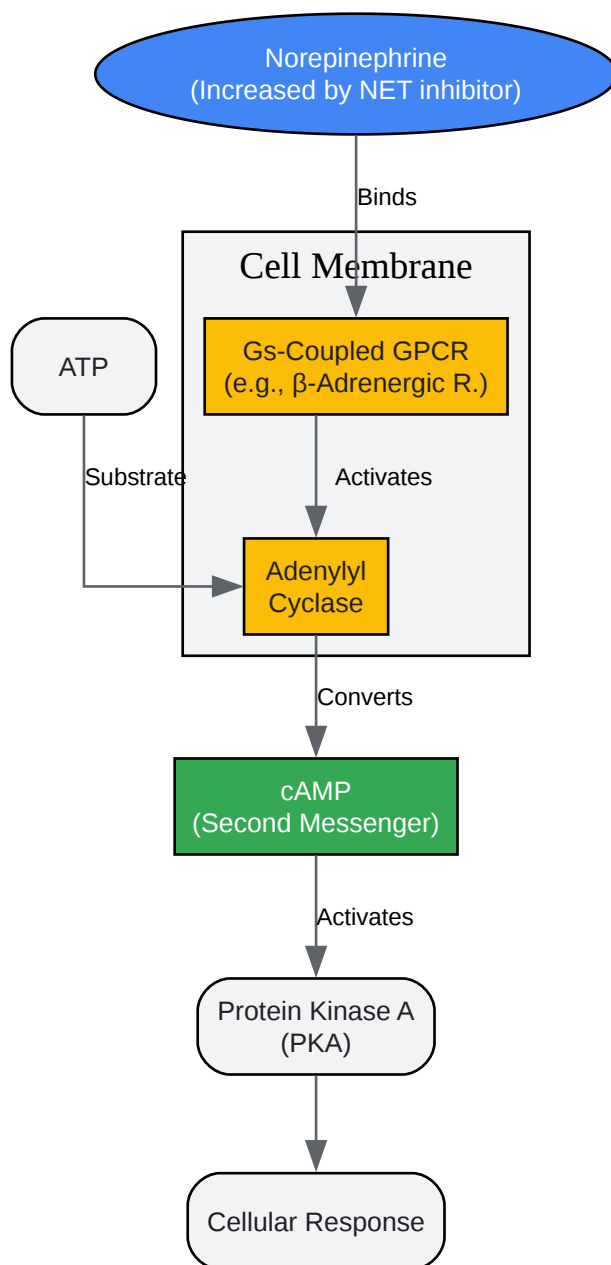

[Click to download full resolution via product page](#)

Caption: Gs-coupled GPCR signaling pathway leading to cAMP production.

Protocol 4.1: Luminescence-Based cAMP Accumulation Assay

This protocol is based on assays that use a luciferase enzyme where light output is inversely proportional to the amount of cAMP produced.[19]

Materials:

- Cell Line: A cell line endogenously expressing a Gs-coupled adrenergic receptor (e.g., CHO-K1 or HEK293).
- Assay Plate: White, opaque 96-well or 384-well microplates suitable for luminescence.
- Reagents: cAMP-Glo™ Assay kit (Promega) or similar.[19]
- Stimulation Buffer: HBSS or other appropriate buffer containing a phosphodiesterase (PDE) inhibitor like IBMX to prevent cAMP degradation.
- Agonist: Isoproterenol (a non-selective β -adrenergic agonist) as a positive control.

Procedure:

- Cell Culture and Induction:
 - Plate cells as described in Protocol 3.1.
 - Prior to the assay, replace the culture medium with 80 μ L of Stimulation Buffer containing the desired concentration of **2-(2-Bromophenyl)morpholine** (or vehicle).
 - Incubate for an appropriate time (e.g., 30 minutes) at 37°C to allow the compound to inhibit NET and for norepinephrine (if using primary neurons or co-cultures) to accumulate and act on receptors. Note: In a simple transfected cell line system, you would add an agonist directly.
- cAMP Detection (as per Promega cAMP-Glo™ protocol):[19]
 - Add 20 μ L of cAMP-Glo™ Lysis Buffer and incubate for 15 minutes at room temperature to lyse the cells and release cAMP.
 - Add 20 μ L of cAMP-Glo™ Detection Solution (containing PKA) and incubate for 20 minutes at room temperature.
 - Add 40 μ L of Kinase-Glo® Reagent to terminate the PKA reaction and initiate the luciferase reaction. Incubate for 10 minutes at room temperature.

- Data Acquisition:
 - Measure luminescence using a plate-reading luminometer. Low luminescence indicates high cAMP levels.

Essential Control: Cell Viability and Cytotoxicity Assay

It is imperative to confirm that the observed effects are due to specific pharmacological activity and not simply because the compound is toxic to the cells.[20] A standard cell viability assay, such as the MTT or MTS assay, measures the metabolic activity of cells, which correlates with the number of viable cells.[21][22]

Protocol 5.1: MTT Cell Viability Assay

This protocol is based on standard, widely published methods.[21][23][24]

Materials:

- Cell Line: The same cell lines used in the primary assays.
- Assay Plate: Standard clear 96-well tissue culture plates.
- Reagents: MTT (3-(4,5-dimethylthiazol-2-yl)-2,5-diphenyltetrazolium bromide) solution (5 mg/mL in PBS), and a solubilization solution (e.g., DMSO or acidic isopropanol).

Procedure:

- Cell Plating and Compound Treatment:
 - Plate cells and treat with the same concentrations of **2-(2-Bromophenyl)morpholine** as used in the primary assays.
 - Incubate for a duration that matches the longest incubation period in the functional assays (e.g., 24 hours to assess general toxicity).
- MTT Incubation:

- Add 10 μL of MTT solution to each 100 μL well.[21]
- Incubate for 2-4 hours at 37°C, allowing viable cells to reduce the yellow MTT to purple formazan crystals.[21]
- Solubilization and Measurement:
 - Carefully remove the medium.
 - Add 100 μL of solubilization solution to each well and mix thoroughly to dissolve the formazan crystals.[21]
 - Measure the absorbance at 570 nm using a microplate reader.

Data Analysis and Presentation

Cell viability is expressed as a percentage of the vehicle-treated control cells. A significant decrease in viability at concentrations where functional activity is observed would confound the interpretation of the results.

Table 2: Hypothetical Cytotoxicity Data for **2-(2-Bromophenyl)morpholine**

Concentration (μM)	% Cell Viability (Mean \pm SD)
0 (Vehicle)	100 \pm 4.5
0.1	98.9 \pm 5.1
1.0	97.2 \pm 4.8
10.0	95.5 \pm 6.2
100.0	88.1 \pm 7.3

This data shows no significant cytotoxicity at concentrations well above the IC_{50} values for NET and DAT, indicating the observed transporter inhibition is not an artifact of cell death.

Conclusion

This application note provides a validated, systematic framework for the initial characterization of **2-(2-Bromophenyl)morpholine**. By following this workflow—from primary screening of monoamine transporters to confirmation of downstream signaling and ruling out cytotoxicity—researchers can build a robust pharmacological profile of the compound. The detailed protocols serve as a reliable starting point for in-depth investigation, enabling confident decision-making in the early stages of drug discovery and development.

References

- Sitte, H. H., & Freissmuth, M. (2015). In vitro assays for the functional characterization of the dopamine transporter (DAT). *Current Protocols in Pharmacology*, 68, 12.15.1-12.15.28. [[Link](#)]
- Murnane, K. S., et al. (2018). Development of serotonin transporter reuptake inhibition assays using JAR cells. *MethodsX*, 5, 268-275. [[Link](#)]
- National Center for Biotechnology Information. (2013). Cell Viability Assays. In *Assay Guidance Manual*. [[Link](#)]
- Molecular Devices. (n.d.). Neurotransmitter Transporter Uptake Assay Kit. [[Link](#)]
- Purohit, D., et al. (2022). An updated review on morpholine derivatives with their pharmacological actions. *International Journal of Health Sciences*, 6(S3), 2218–2243. [[Link](#)]
- Wang, T., et al. (2017). Measurement of cAMP for Gas- and Gai Protein-Coupled Receptors (GPCRs). In *Assay Guidance Manual*. National Center for Biotechnology Information. [[Link](#)]
- Luethi, D., et al. (2020). Cell-Based Radiotracer Binding and Uptake Inhibition Assays: A Comparison of In Vitro Methods to Assess the Potency of Drugs That Target Monoamine Transporters. *Frontiers in Pharmacology*, 11, 674. [[Link](#)]
- Zhang, R., & Xie, X. (2012). Recent progress in assays for GPCR drug discovery. *Acta Pharmacologica Sinica*, 33(3), 372-384. [[Link](#)]
- National Center for Biotechnology Information. (2019). Cytotoxicity Assays: In Vitro Methods to Measure Dead Cells. In *Assay Guidance Manual*. [[Link](#)]

- Molecular Devices. (n.d.). Neurotransmitter Transporter Uptake Assay Kit - Technical Data Sheet. [\[Link\]](#)
- BioIVT. (n.d.). NET (SLC6A2) Transporter Assay. [\[Link\]](#)
- van der Velden, W. J. C., et al. (2022). Setup and Evaluation of the TRACT Assay Principle for the In Vitro Functional Characterization of Modulators of the Serotonin Transporter and the Serotonin 2A Receptor. *Analytical Chemistry*, 94(35), 12089–12097. [\[Link\]](#)
- Eurofins Discovery. (n.d.). DAT Human Dopamine Transporter Functional Antagonist Uptake LeadHunter Assay. [\[Link\]](#)
- Cell Biolabs, Inc. (n.d.). Monoamine Oxidase Assays. [\[Link\]](#)
- Stoeber, M., et al. (2023). Molecular insights into GPCR mechanisms for drugs of abuse. *Journal of Biological Chemistry*, 299(3), 102941. [\[Link\]](#)
- Kumar, P., & Singh, R. K. (2020). Morpholine as ubiquitous pharmacophore in medicinal chemistry: Deep insight into the structure-activity relationship (SAR). *Bioorganic chemistry*, 96, 103578. [\[Link\]](#)
- Arunachalam, K., & Sreeja, P. S. (2025). In Vitro Cytotoxicity Testing of Novel Drug Molecules Using MTT Assay. *ResearchGate*. [\[Link\]](#)
- National Center for Advancing Translational Sciences. (2019). Measurement of cAMP for Gas- and Gai Protein-Coupled Receptors (GPCRs). *Assay Guidance Manual*. [\[Link\]](#)
- Molecular Devices. (n.d.). Neurotransmitter Transporter Uptake Assay Kit Datasheet. [\[Link\]](#)
- Eurofins Discovery. (n.d.). SERT Human Serotonin Transporter Functional Antagonist Uptake LeadHunter Assay. [\[Link\]](#)
- Springer Nature Experiments. (n.d.). Cytotoxicity MTT Assay Protocols and Methods. [\[Link\]](#)
- Rekka, E. A., & Kourounakis, P. N. (2000). Medicinal chemistry of 2,2,4-substituted morpholines. *Current medicinal chemistry*, 7(11), 1077–1093. [\[Link\]](#)
- Evotec. (n.d.). Monoamine Oxidase (MAO) Inhibition Assay. [\[Link\]](#)

- BioIVT. (n.d.). DAT (SLC6A3) Transporter Assay. [\[Link\]](#)
- Eurofins Discovery. (n.d.). GPCR Functional Assays, Understanding On/Off-target Activity. [\[Link\]](#)
- Hahn, M. K., et al. (2003). A Mutation in the Human Norepinephrine Transporter Gene (SLC6A2) Associated with Orthostatic Intolerance Disrupts Surface Expression of Mutant and Wild-Type Transporters. *Journal of Neuroscience*, 23(10), 4220-4228. [\[Link\]](#)
- Adan, A., et al. (2021). Cell Proliferation and Cytotoxicity Assays, The Fundamentals for Drug Discovery. *Molecules*, 26(21), 6430. [\[Link\]](#)
- Sharma, P. K., et al. (2023). Synthesis and SAR of morpholine and its derivatives: A review update. *E3S Web of Conferences*, 391, 01053. [\[Link\]](#)
- Rajagopal, S., et al. (2017). cAMP assays in GPCR drug discovery. *Methods in molecular biology*, 1654, 1-17. [\[Link\]](#)
- Georgieva, M., et al. (2021). Monoamine Oxidase Inhibitors in Drug Discovery Against Parkinson's Disease: An Update. *International journal of molecular sciences*, 22(16), 8774. [\[Link\]](#)
- Purohit, D., et al. (2022). An updated review on morpholine derivatives with their pharmacological actions. *International Journal of Health Sciences*. [\[Link\]](#)
- Samuvel, D. J., et al. (2008). Real-time, Spatially Resolved Analysis of Serotonin Transporter Activity and Regulation Using the Fluorescent Substrate, ASP+. *Neuroscience*, 154(3), 933-943. [\[Link\]](#)
- Creative BioMart. (n.d.). cAMP Accumulation Assay. [\[Link\]](#)
- Zhang, R., & Xie, X. (2022). Recent progress in assays for GPCR drug discovery. *American journal of physiology. Cell physiology*, 323(2), C419–C431. [\[Link\]](#)
- Pramod, A. B., et al. (2013). Model Systems for Analysis of Dopamine Transporter Function and Regulation. *ACS chemical neuroscience*, 4(1), 85–97. [\[Link\]](#)

- de Witte, W. E. A., et al. (2021). Label-free high-throughput screening assay for the identification of norepinephrine transporter (NET/SLC6A2) inhibitors. *Scientific reports*, 11(1), 12275. [[Link](#)]
- Creative Biolabs. (n.d.). Monoamine Oxidase B (MAO-B) Inhibitor Screening Kit (Fluorometric). [[Link](#)]
- Eurofins Discovery. (n.d.). SERT Human Serotonin Transporter Functional Antagonist Uptake LeadHunter Assay - FR. [[Link](#)]

Need Custom Synthesis?

BenchChem offers custom synthesis for rare earth carbides and specific isotopic labeling.

Email: info@benchchem.com or [Request Quote Online](#).

Sources

1. [researchgate.net](https://www.researchgate.net) [[researchgate.net](https://www.researchgate.net)]
2. Morpholine as ubiquitous pharmacophore in medicinal chemistry: Deep insight into the structure-activity relationship (SAR) - PubMed [pubmed.ncbi.nlm.nih.gov]
3. [e3s-conferences.org](https://www.e3s-conferences.org) [[e3s-conferences.org](https://www.e3s-conferences.org)]
4. [sciencescholar.us](https://www.sciencescholar.us) [[sciencescholar.us](https://www.sciencescholar.us)]
5. Cell-Based Radiotracer Binding and Uptake Inhibition Assays: A Comparison of In Vitro Methods to Assess the Potency of Drugs That Target Monoamine Transporters - PMC [[pmc.ncbi.nlm.nih.gov](https://pubmed.ncbi.nlm.nih.gov)]
6. In vitro assays for the functional characterization of the dopamine transporter (DAT) - PMC [[pmc.ncbi.nlm.nih.gov](https://pubmed.ncbi.nlm.nih.gov)]
7. [bioivt.com](https://www.bioivt.com) [[bioivt.com](https://www.bioivt.com)]
8. [emea.eurofindiscovery.com](https://www.emea.eurofindiscovery.com) [[emea.eurofindiscovery.com](https://www.emea.eurofindiscovery.com)]
9. Molecular insights into GPCR mechanisms for drugs of abuse - PMC [[pmc.ncbi.nlm.nih.gov](https://pubmed.ncbi.nlm.nih.gov)]
10. [apac.eurofindiscovery.com](https://www.apac.eurofindiscovery.com) [[apac.eurofindiscovery.com](https://www.apac.eurofindiscovery.com)]
11. Model Systems for Analysis of Dopamine Transporter Function and Regulation - PMC [[pmc.ncbi.nlm.nih.gov](https://pubmed.ncbi.nlm.nih.gov)]

- [12. Neurotransmitter Transporter Assay Kit | Molecular Devices \[moleculardevices.com\]](#)
- [13. moleculardevices.com \[moleculardevices.com\]](#)
- [14. moleculardevices.com \[moleculardevices.com\]](#)
- [15. eurofindiscovery.com \[eurofindiscovery.com\]](#)
- [16. Label-free high-throughput screening assay for the identification of norepinephrine transporter \(NET/SLC6A2\) inhibitors - PubMed \[pubmed.ncbi.nlm.nih.gov\]](#)
- [17. cAMP assays in GPCR drug discovery - PubMed \[pubmed.ncbi.nlm.nih.gov\]](#)
- [18. cAMP Accumulation Assay - Creative BioMart \[creativebiomart.net\]](#)
- [19. cAMP-Glo™ Assay \[promega.jp\]](#)
- [20. MTT assay overview | Abcam \[abcam.com\]](#)
- [21. Cell Viability Assays - Assay Guidance Manual - NCBI Bookshelf \[ncbi.nlm.nih.gov\]](#)
- [22. Cell viability assays | Abcam \[abcam.com\]](#)
- [23. researchgate.net \[researchgate.net\]](#)
- [24. atcc.org \[atcc.org\]](#)
- To cite this document: BenchChem. [cell-based assays to evaluate 2-(2-Bromophenyl)morpholine activity]. BenchChem, [2026]. [Online PDF]. Available at: [\[https://www.benchchem.com/product/b1289296/docs#cell-based-assays-to-evaluate-2-2-bromophenyl-morpholine-activity\]](https://www.benchchem.com/product/b1289296/docs#cell-based-assays-to-evaluate-2-2-bromophenyl-morpholine-activity)

Disclaimer & Data Validity:

The information provided in this document is for Research Use Only (RUO) and is strictly not intended for diagnostic or therapeutic procedures. While BenchChem strives to provide accurate protocols, we make no warranties, express or implied, regarding the fitness of this product for every specific experimental setup.

Technical Support: The protocols provided are for reference purposes. Unsure if this reagent suits your experiment?

Need Industrial/Bulk Grade? [Request Custom Synthesis Quote](#)

BenchChem

Our mission is to be the trusted global source of essential and advanced chemicals, empowering scientists and researchers to drive progress in science and industry.

Contact

Address: 3281 E Guasti Rd

Ontario, CA 91761, United States

Phone: (601) 213-4426

Email: info@benchchem.com

[Contact our Ph.D. Support Team for a compatibility check](#)