

The Alchemist's Catalyst: A Modern Guide to Microwave-Assisted Indole Synthesis

Author: BenchChem Technical Support Team. **Date:** May 2026

Compound of Interest

Compound Name:	<i>1-benzyl-1H-indole-6-carboxylic acid</i>
CAS No.:	1030423-79-0
Cat. No.:	B1289464

[Get Quote](#)

For researchers, medicinal chemists, and professionals in drug development, the indole scaffold represents a "privileged" structure, forming the backbone of a multitude of natural products and pharmaceuticals.^[1] However, classical synthetic routes to these vital heterocycles are often plagued by long reaction times, harsh conditions, and modest yields.^[1] ^[2] This guide delves into the transformative power of Microwave-Assisted Organic Synthesis (MAOS), a technology that has revolutionized the construction of indole derivatives, offering a faster, more efficient, and greener path to these valuable molecules.^{[1][2]}

The Microwave Advantage: More Than Just a Kitchen Appliance

At its core, microwave chemistry utilizes the ability of polar molecules and ions to absorb microwave energy and convert it into heat.^[3] This dielectric heating is fundamentally different from conventional heating methods that rely on conduction and convection. The result is rapid, uniform, and efficient heating of the reaction mixture, leading to dramatic accelerations in reaction rates.^{[1][3]} Reactions that once took hours or even days can often be completed in a matter of minutes.^[1] This efficiency not only accelerates research and development but also

aligns with the principles of green chemistry by reducing energy consumption and often allowing for the use of less solvent.^{[2][4]}

Foundational Indole Syntheses Accelerated by Microwave Irradiation

The Fischer Indole Synthesis: A Classic Reimagined

The Fischer indole synthesis, a cornerstone of heterocyclic chemistry, involves the acid-catalyzed cyclization of an arylhydrazone. While robust, this method traditionally requires prolonged heating.^[1] Microwave irradiation has been shown to dramatically reduce reaction times and improve yields, as demonstrated in the synthesis of 2-phenylindole.

Comparative Analysis: Fischer Indole Synthesis

Reactants	Heating Method	Catalyst / Reagent	Solvent	Time	Temperature	Yield (%)	Reference
Phenylhydrazine, Propiophenone	Conventional	Acetic Acid	Acetic Acid	8 hours	Reflux	75	[5]
Phenylhydrazine, Propiophenone	Microwave	Eaton's Reagent	-	10 min	170°C	92	[1][5]
Phenylhydrazine, Cyclohexanone	Conventional	Zinc Chloride	-	-	-	76	[5]

Protocol: Microwave-Assisted Fischer Indole Synthesis of 2-Phenylindole^[6]

- Materials:

- Phenylhydrazine (1.0 mmol, 108 mg)
- Propiophenone (1.0 mmol, 134 mg)
- Eaton's Reagent (Phosphorus pentoxide in methanesulfonic acid, 1:10 w/w, 2 mL)
- 10 mL microwave vial with a magnetic stir bar
- Microwave reactor
- Procedure:
 - In a 10 mL microwave vial equipped with a magnetic stir bar, combine phenylhydrazine (1.0 mmol) and propiophenone (1.0 mmol).
 - Carefully add Eaton's Reagent (2 mL) to the vial.
 - Seal the vial and place it in the microwave reactor.
 - Irradiate the reaction mixture at 170°C for 10 minutes with stirring.
 - After the reaction is complete, allow the vial to cool to room temperature.
 - Carefully quench the reaction mixture by pouring it onto crushed ice.
 - Neutralize the solution with a saturated aqueous solution of sodium bicarbonate.
 - Extract the product with an appropriate organic solvent (e.g., ethyl acetate), dry the organic layer over anhydrous sodium sulfate, and concentrate under reduced pressure to obtain the crude product.
 - Purify the crude product by column chromatography if necessary.

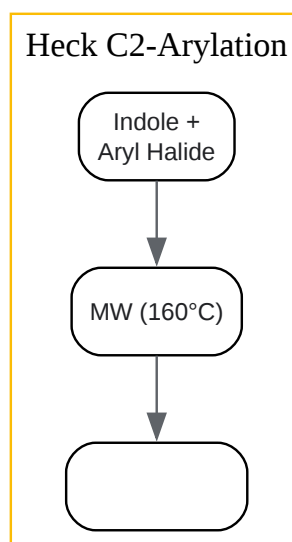
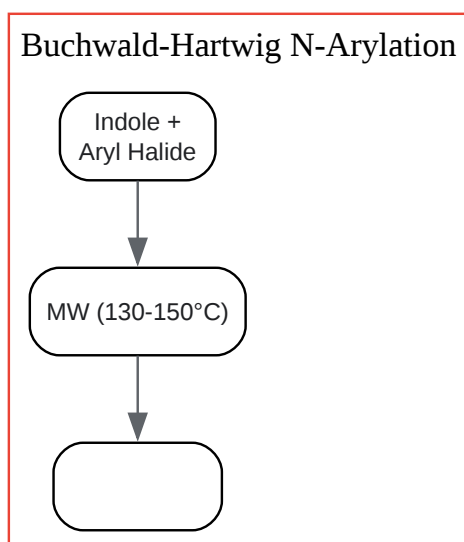
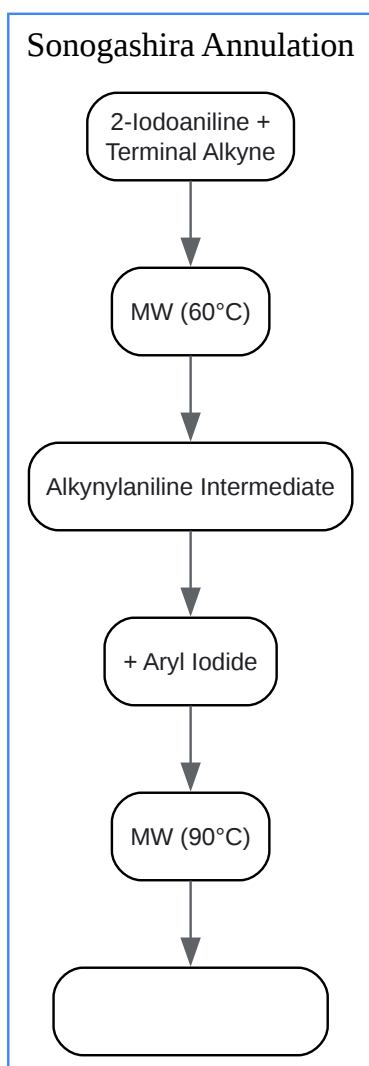
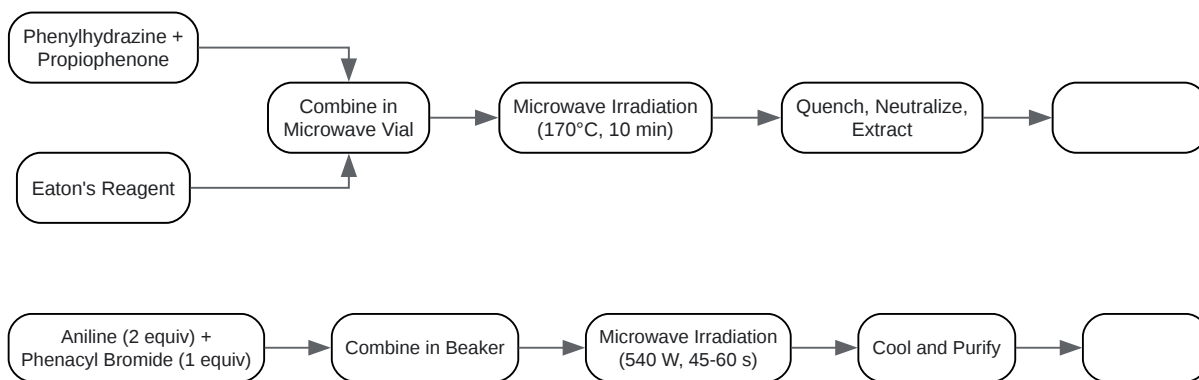

[Click to download full resolution via product page](#)

Need Custom Synthesis?

BenchChem offers custom synthesis for rare earth carbides and specific isotopic labeling.

Email: info@benchchem.com or [Request Quote Online](#).

Sources

- [1. ijrpr.com](http://ijrpr.com) [ijrpr.com]
- [2. tandfonline.com](http://tandfonline.com) [tandfonline.com]
- [3. Microwave assisted synthesis of five membered nitrogen heterocycles - PMC](http://pmc.ncbi.nlm.nih.gov) [pmc.ncbi.nlm.nih.gov]
- [4. Microwave assisted synthesis of five membered nitrogen heterocycles - RSC Advances \(RSC Publishing\)](http://pubs.rsc.org) [pubs.rsc.org]
- [5. pdf.benchchem.com](http://pdf.benchchem.com) [pdf.benchchem.com]
- [6. pdf.benchchem.com](http://pdf.benchchem.com) [pdf.benchchem.com]
- To cite this document: BenchChem. [The Alchemist's Catalyst: A Modern Guide to Microwave-Assisted Indole Synthesis]. BenchChem, [2026]. [Online PDF]. Available at: [<https://www.benchchem.com/product/b1289464/docs#the-chemist-s-catalyst-a-modern-guide-to-microwave-assisted-indole-synthesis>]

Disclaimer & Data Validity:

The information provided in this document is for Research Use Only (RUO) and is strictly not intended for diagnostic or therapeutic procedures. While BenchChem strives to provide accurate protocols, we make no warranties, express or implied, regarding the fitness of this product for every specific experimental setup.

Technical Support: The protocols provided are for reference purposes. Unsure if this reagent suits your experiment?

Need Industrial/Bulk Grade? [Request Custom Synthesis Quote](#)

BenchChem

Our mission is to be the trusted global source of essential and advanced chemicals, empowering scientists and researchers to drive progress in science and industry.

Contact

Address: 3281 E Guasti Rd
Ontario, CA 91761, United States
Phone: (601) 213-4426
Email: info@benchchem.com

[Contact our Ph.D. Support Team for a compatibility check](#)