

Technical Support Center: Improving Coupling Reaction Yields with Hindered Amino Acids

Author: BenchChem Technical Support Team. **Date:** May 2026

Compound of Interest

Compound Name: (3-Bromophenyl)[(tert-butoxycarbonyl)amino]acetic acid

CAS No.: 446305-66-4

Cat. No.: B1288552

[Get Quote](#)

Welcome to the technical support center dedicated to addressing one of the most persistent challenges in solid-phase peptide synthesis (SPPS): the efficient coupling of sterically hindered amino acids. This guide provides in-depth troubleshooting advice, detailed protocols, and answers to frequently asked questions to help researchers, chemists, and drug development professionals overcome low-yield reactions and achieve higher purity of their target peptides.

Introduction: The Challenge of Steric Hindrance

Peptide synthesis is the stepwise formation of amide bonds between amino acids.[1][2] The success of this process relies on the efficient reaction between the activated carboxylic acid of one amino acid and the N-terminal amine of the growing peptide chain.[3] Sterically hindered amino acids, such as those with bulky side chains (e.g., Val, Ile), α,α -disubstituted amino acids (e.g., Aib), or N-methylated amino acids, present a significant physical barrier to this reaction.[4][5] This obstruction slows down the reaction rate and can lead to incomplete or failed couplings, resulting in deletion sequences and difficult purifications.[5][6]

Furthermore, sequences containing multiple hydrophobic or β -branched amino acids are prone to forming secondary structures (e.g., β -sheets) on the solid support.[7][8] This aggregation can render the N-terminal amine inaccessible, effectively stopping the synthesis.[6][8] This guide will walk you through the causes of these issues and provide field-proven solutions.

Troubleshooting Guide: Overcoming Low Coupling Efficiency

This section is designed as a direct response to the common observation of a failed or low-yield coupling reaction involving a hindered amino acid.

Issue: My coupling reaction has failed or is showing very low yield.

This is the most frequent problem encountered when working with hindered residues. The cause can typically be traced to one of four main areas: the coupling reagent, the reaction conditions, the solvent system, or a combination thereof.

Potential Cause 1: Inefficient Coupling Reagent

Why it happens: Standard carbodiimide reagents like Dicyclohexylcarbodiimide (DCC) or Diisopropylcarbodiimide (DIC), even with additives like HOBt, are often not potent enough to overcome the high activation energy required for sterically demanding couplings.[4][5] Their activated intermediates are not reactive enough to couple efficiently to a hindered N-terminus or from a hindered carboxylic acid.

Solution: Employ a High-Potency Activating Reagent.

Switching to a more powerful in-situ activating reagent is the most critical first step. These reagents form highly reactive esters that can overcome the steric barrier.

- **Aminium/Uronium Salts:** Reagents like HATU, HBTU, and HCTU are significantly more effective.[2] HATU, in the presence of a base, forms a highly reactive OAt-ester, which is superior for difficult couplings due to the anchimeric assistance provided by the pyridine nitrogen in the HOAt leaving group.[2]

- Phosphonium Salts: Reagents like PyBOP and PyAOP are also excellent choices for hindered couplings.[2]
- COMU: This uronium salt incorporates the non-explosive Oxyma Pure leaving group, offering coupling efficiencies comparable to HATU with enhanced safety and solubility.[9][10]
- For Extreme Cases (e.g., Aib-Aib coupling): Converting the carboxylic acid to an acyl fluoride using reagents like TFFH is a highly effective strategy.[9] Amino acid fluorides are among the most reactive species used in SPPS and are particularly suited for coupling sterically demanding α,α -disubstituted amino acids.[9]

Reagent	Class	Activated Intermediate	Key Advantages
HATU	Aminium	OAt-Ester	High reactivity, well-established for difficult couplings.[2]
HCTU	Aminium	O-6-CIBt Ester	More cost-effective than HATU, high reactivity.[2][11]
PyAOP	Phosphonium	OAt-Ester	High reactivity, avoids guanidinium side products.[4]
COMU	Aminium	Oxyma-Ester	High reactivity, safer (non-explosive), good solubility.[9][10]
TOTT	Thiuronium	Thiuronium Salt	Good results with N-methylated amino acids, lower racemization reported.[9]
TFFH	Formamidinium	Acyl Fluoride	Excellent for extremely hindered couplings (e.g., Aib).[9]

Potential Cause 2: Insufficient Reaction Time or Temperature

Why it happens: Steric hindrance dramatically slows down the kinetics of the coupling reaction. A standard reaction time of 1-2 hours may be insufficient for the reaction to reach completion.

[5]

Solutions:

- **Increase Reaction Time:** Extend the coupling time significantly. For particularly difficult couplings, allowing the reaction to proceed overnight can be beneficial.[5]
- **Double Coupling:** Perform the coupling reaction twice. After the first coupling, wash the resin and then add a fresh solution of the activated amino acid to couple any remaining free amines.[3][6] This is a very common and effective strategy.
- **Elevated Temperature:** Gently heating the reaction vessel (e.g., to 35-50°C) can help overcome the activation energy barrier.[3] However, this must be done cautiously as excessive heat can increase the risk of racemization.[9]
- **Microwave-Assisted SPPS (MA-SPPS):** This is a highly effective method for driving difficult couplings to completion.[12] Microwave energy efficiently heats the reaction, dramatically shortening the required time (e.g., from hours to minutes) while often minimizing side reactions like racemization.[5][12]

Potential Cause 3: Poor Solvation and On-Resin Aggregation

Why it happens: The growing peptide chain, especially if it's hydrophobic, can fold and aggregate on the resin support, physically blocking the N-terminal amine from reacting.[6][8]

The solvent must be able to properly swell the resin and solvate the peptide chains to prevent this.

Solutions:

- **Optimize Your Solvent:** While Dimethylformamide (DMF) is the most common solvent, N-methylpyrrolidone (NMP) often has superior solvating properties and is a better choice for difficult or hydrophobic sequences.[5][6]

- Use Solvent Mixtures: For exceptionally difficult sequences, a mixture of solvents such as DCM/DMF/NMP (1:1:1) can disrupt secondary structures and improve solvation.^[5]
- Employ "Chaotropic" Salts: Adding a low concentration of a salt like LiCl (e.g., 0.5 M) to the coupling reaction can help disrupt hydrogen bonding and break up aggregates, improving reaction efficiency.

Troubleshooting Workflow Diagram

The following diagram outlines a logical workflow for diagnosing and solving low-yield coupling reactions with hindered amino acids.

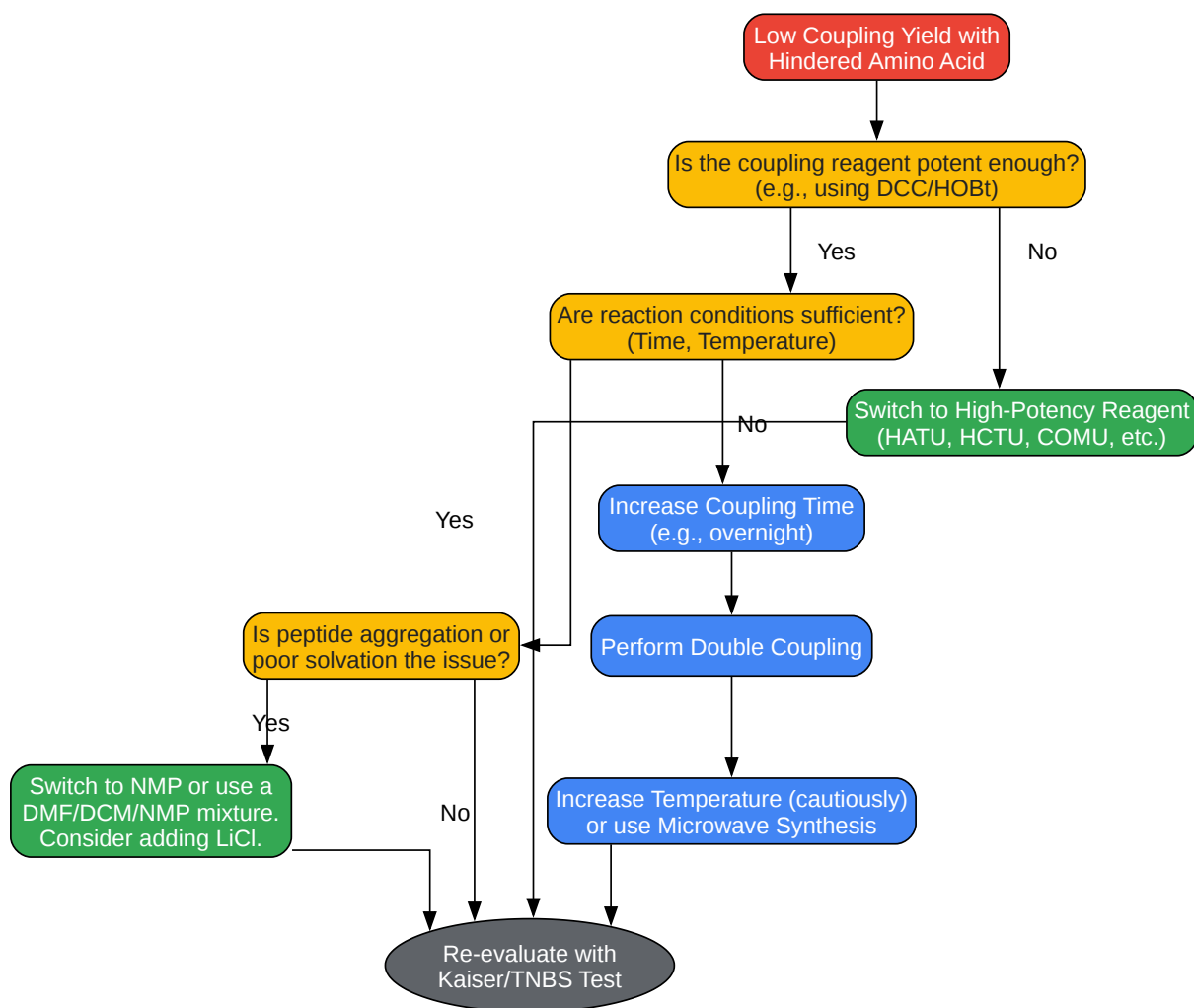

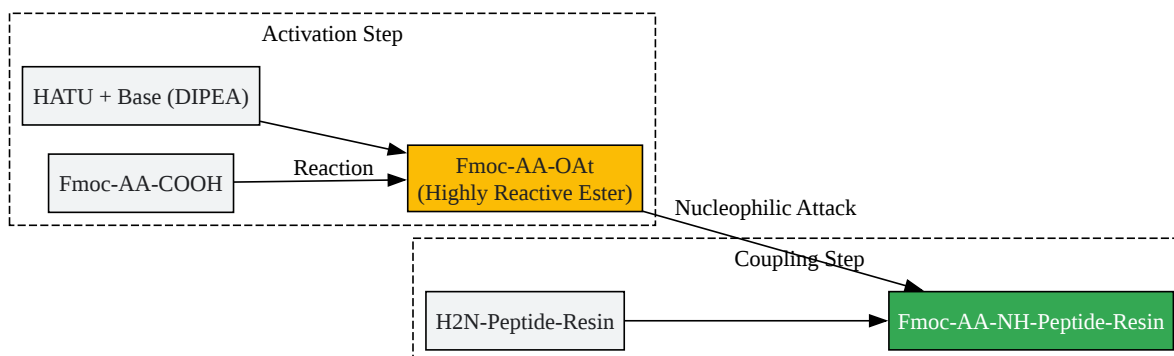

[Click to download full resolution via product page](#)

Caption: Simplified mechanism of uronium salt activation.

Key Experimental Protocols

Note: Equivalents (eq) are relative to the substitution loading of the solid-phase resin. Always use high-quality, anhydrous solvents.

Protocol 1: High-Efficiency Double Coupling with HATU

This protocol is a robust starting point for a difficult coupling.

- Resin Preparation: Swell the resin in DMF for 30-60 minutes. Perform the standard Fmoc-deprotection of the N-terminal amine and wash thoroughly with DMF.
- First Coupling Activation: In a separate vessel, dissolve the hindered Fmoc-amino acid (4 eq), HATU (3.9 eq), and DIPEA (8 eq) in DMF.
- Pre-activation: Allow the activation mixture to stand for 1-5 minutes.
- First Coupling Reaction: Add the activated amino acid solution to the deprotected peptidyl-resin. Agitate the reaction for 2 hours at room temperature.

- Wash: Filter the reaction solution and wash the resin thoroughly with DMF (3-5 times).
- Second Coupling: Repeat steps 2-4 with a fresh solution of activated amino acid. Agitate for another 2 hours.
- Final Wash: Wash the resin thoroughly with DMF, then DCM, and dry for the next step.
- Verification: Take a small sample of resin beads and perform a Kaiser or TNBS test to confirm the absence of free amines. [8]

Protocol 2: Acyl Fluoride Formation for Extremely Hindered Couplings

This protocol is for cases where even potent uronium reagents fail, such as coupling two Aib residues.

- Acyl Fluoride Formation: In a dry reaction vessel, dissolve the hindered Fmoc-amino acid (4 eq) in anhydrous DCM. Cool the solution to 0°C. Add TFFH (3.9 eq) and DIPEA (8 eq). Stir the reaction at 0°C for 15-20 minutes. The Fmoc-amino acid fluoride is formed in situ.
- Resin Preparation: Ensure the peptidyl-resin is deprotected and washed as described in Protocol 1.
- Coupling Reaction: Add the solution containing the pre-formed acyl fluoride to the resin. Allow the reaction to proceed for 4-6 hours, or overnight if necessary, at room temperature.
- Wash and Verify: Wash the resin as described in Protocol 1 and verify the completion of the reaction with a Kaiser test.

References

- Challenges and Achievements of Peptide Synthesis in Aqueous and Micellar Media. ChemBioChem. [Link]
- Efficient Peptide Coupling Involving Sterically Hindered Amino Acids. ResearchGate. [Link]
- Challenges and Perspectives in Chemical Synthesis of Highly Hydrophobic Peptides. Frontiers in Bioengineering and Biotechnology. [Link]

- Peptide Synthesis Using Unprotected Amino Acids. ChemRxiv. [\[Link\]](#)
- Procedures to Improve Difficult Couplings. ResearchGate. [\[Link\]](#)
- Sustainability Challenges in Peptide Synthesis and Purification: From R&D to Production. The Journal of Organic Chemistry. [\[Link\]](#)
- What do you do when your peptide synthesis fails?. Biotage. [\[Link\]](#)
- Efficient Peptide Coupling Involving Sterically Hindered Amino Acids. ACS Publications. [\[Link\]](#)
- Peptide Coupling Reagents, More than a Letter Soup. Chemical Reviews. [\[Link\]](#)

Need Custom Synthesis?

BenchChem offers custom synthesis for rare earth carbides and specific isotopic labeling.

Email: info@benchchem.com or [Request Quote Online](#).

Sources

- 1. chemrxiv.org [chemrxiv.org]
- 2. [Peptide Coupling Reagents Guide](https://www.sigmaaldrich.com) [[sigmaaldrich.com](https://www.sigmaaldrich.com)]
- 3. [researchgate.net](https://www.researchgate.net) [[researchgate.net](https://www.researchgate.net)]
- 4. [researchgate.net](https://www.researchgate.net) [[researchgate.net](https://www.researchgate.net)]
- 5. pdf.benchchem.com [pdf.benchchem.com]
- 6. [biotage.com](https://www.biotage.com) [[biotage.com](https://www.biotage.com)]
- 7. [Challenges and Perspectives in Chemical Synthesis of Highly Hydrophobic Peptides - PMC](https://pubmed.ncbi.nlm.nih.gov) [[pmc.ncbi.nlm.nih.gov](https://pubmed.ncbi.nlm.nih.gov)]
- 8. [Overcoming Aggregation in Solid-phase Peptide Synthesis](https://www.sigmaaldrich.com) [[sigmaaldrich.com](https://www.sigmaaldrich.com)]
- 9. [bachem.com](https://www.bachem.com) [[bachem.com](https://www.bachem.com)]
- 10. pubs.acs.org [pubs.acs.org]
- 11. people.uniurb.it [people.uniurb.it]

- [12. Challenges and Achievements of Peptide Synthesis in Aqueous and Micellar Media - PMC \[pmc.ncbi.nlm.nih.gov\]](#)
- To cite this document: BenchChem. [Technical Support Center: Improving Coupling Reaction Yields with Hindered Amino Acids]. BenchChem, [2026]. [Online PDF]. Available at: [\[https://www.benchchem.com/product/b1288552/docs#technical-support-center-improving-coupling-reaction-yields-with-hindered-amino-acids\]](https://www.benchchem.com/product/b1288552/docs#technical-support-center-improving-coupling-reaction-yields-with-hindered-amino-acids)

Disclaimer & Data Validity:

The information provided in this document is for Research Use Only (RUO) and is strictly not intended for diagnostic or therapeutic procedures. While BenchChem strives to provide accurate protocols, we make no warranties, express or implied, regarding the fitness of this product for every specific experimental setup.

Technical Support: The protocols provided are for reference purposes. Unsure if this reagent suits your experiment?

Need Industrial/Bulk Grade? [Request Custom Synthesis Quote](#)

BenchChem

Our mission is to be the trusted global source of essential and advanced chemicals, empowering scientists and researchers to drive progress in science and industry.

Contact

Address: 3281 E Guasti Rd
Ontario, CA 91761, United States
Phone: (601) 213-4426
Email: info@benchchem.com

[Contact our Ph.D. Support Team for a compatibility check](#)