

Comparative Study of Leaving Group Potential in Phenethyl Halides

Author: BenchChem Technical Support Team. **Date:** May 2026

Compound of Interest

Compound Name: 1-(2-Bromoethyl)-2,3,4-trifluorobenzene

CAS No.: 887586-25-6

Cat. No.: B1288316

[Get Quote](#)

Executive Summary

This guide provides a technical analysis of the nucleofugality (leaving group ability) of phenethyl halides (2-phenylethyl halides, Ph-CH₂-CH₂-X). Unlike simple alkyl halides, phenethyl substrates exhibit a unique reactivity profile due to the

-phenyl ring, which can influence reaction pathways via steric hindrance, inductive effects, and anchimeric assistance (the "phenethyl effect"). This comparative study analyzes the kinetic performance of Fluoride (F), Chloride (Cl), Bromide (Br), and Iodide (I) to aid researchers in optimizing synthetic routes and understanding metabolic stability in drug development.

Mechanistic Landscape

The reactivity of phenethyl halides is governed by the competition between direct nucleophilic substitution (

), elimination (

), and aryl-assisted ionization (

).

The Phenethyl Effect

In solvolytic conditions, the

-phenyl ring can act as an intramolecular nucleophile, displacing the leaving group to form a bridged phenonium ion intermediate. This pathway (

) competes with direct solvent attack (

).

- Leaving Group Impact: Better leaving groups (I, Br) facilitate ionization, making the pathway more accessible in low-nucleophilicity solvents. Poor leaving groups (F) rarely undergo this pathway without significant acid catalysis.

vs. Competition

Phenethyl halides are particularly prone to

elimination to form styrene. The acidity of the benzylic protons (at the

-position) combined with the conjugation of the resulting alkene lowers the transition state energy for elimination.

- Trend: The ratio of Elimination to Substitution () generally increases with the basicity of the leaving group and the hardness of the nucleophile.

Visualization: Reaction Pathways

The following diagram illustrates the competing pathways for a generic phenethyl halide.

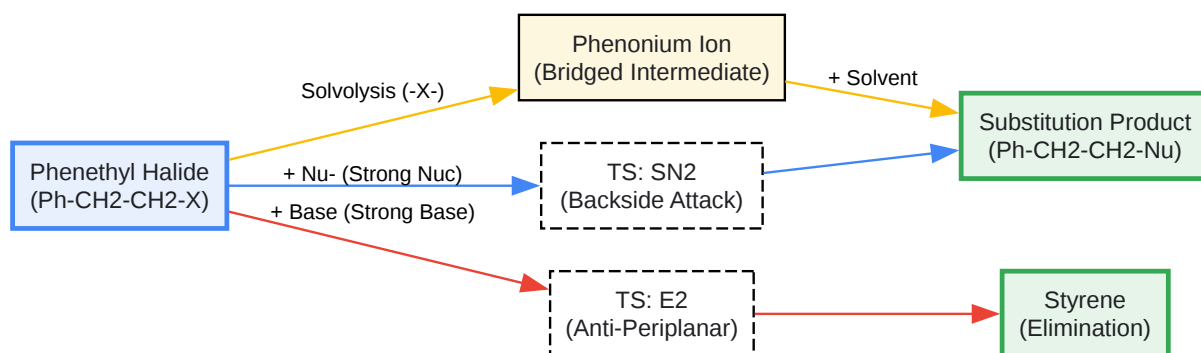

[Click to download full resolution via product page](#)

Figure 1: Competing reaction manifolds for phenethyl halides. Blue path:

; Red path:

; Yellow path: Aryl-assisted ionization (

).

Comparative Kinetic Analysis

The leaving group ability is fundamentally linked to the C-X bond dissociation energy (BDE) and the

of the conjugate acid (HX).

Quantitative Comparison Matrix

Halide (X)	C-X BDE (kcal/mol)	of HX	Relative Rate () ()*	Primary Utility
Iodide (I)	~53	-10	30,000	Highly reactive alkylating agent; Finkelstein product.
Bromide (Br)	~68	-9	10,000	Standard balance of stability and reactivity.
Chloride (Cl)	~81	-7	200	Stable precursor; requires activation (KI) or strong nucleophiles.
Fluoride (F)	~108	+3.2	1	Metabolic blocker; PET radiotracer (¹⁸ F); Inert leaving group.

*Note:

values are approximate for standard methanolic solvolysis/substitution and can vary by solvent system.

Detailed Halide Profiles

Phenethyl Iodide (The "Hot" Electrophile)

- Performance: Exhibits the highest reaction rates due to the weak C-I bond and the high polarizability of the iodide anion (soft base).

- Risk: Prone to rapid degradation and light sensitivity. In drug synthesis, it is often generated in situ (Finkelstein conditions) rather than isolated.
- Experimental Insight: Use immediately upon synthesis.

Phenethyl Bromide (The Workhorse)

- Performance: The standard compromise. The C-Br bond is stable enough for storage but reactive enough for direct alkylation of amines and thiols.
- E2 Liability: Phenethyl bromide is 350-fold more reactive in E2 elimination than ethyl bromide due to the phenyl ring's stabilization of the transition state [1].

Phenethyl Chloride (The Stable Precursor)

- Performance: significantly slower kinetics. Often requires elevated temperatures or iodide catalysis (Finkelstein conditions) to proceed.
- Utility: Preferred for scale-up when reaction conditions allow for longer times, due to lower cost and higher atom economy compared to bromide/iodide.

Phenethyl Fluoride (The Metabolic Shield)

- Performance: Essentially inert to substitution under standard conditions. The C-F bond strength renders it a poor leaving group.[1]
- Application: Used in medicinal chemistry to block metabolic "soft spots" (preventing oxidation at the -carbon) or as a target for ^{18}F -PET imaging, where the fluoride is the nucleophile introduced, not the leaving group.

Experimental Protocols

Protocol A: Kinetic Determination via Conductometry (Solvolysis)

This protocol measures the rate of halide release (

) in a solvolytic environment.

Objective: Determine the first-order rate constant for phenethyl halide solvolysis. Reagents: Phenethyl halide (0.01 M), Ethanol/Water (80:20 v/v).

- Setup: Thermostat a reaction vessel containing 50 mL of 80% EtOH at $25.0\text{ }^{\circ}\text{C} \pm 0.1\text{ }^{\circ}\text{C}$.
- Initiation: Inject phenethyl halide to reach a concentration of 0.01 M. Start timer ().
- Monitoring: Immerse a conductivity cell. The conductivity () will increase as HX is generated.
- Data Acquisition: Record conductance () at 30-second intervals until .
- Calculation:
 - Measure infinite conductance () after 24 hours or by heating a sample to completion.
 - Plot vs. time ().
 - The slope of the line is .

Protocol B: Finkelstein Conversion (Cl/Br I)

Objective: Convert Phenethyl Bromide to Phenethyl Iodide to enhance electrophilicity. Principle: Solubility differential. NaI is soluble in acetone; NaBr is not.

- Dissolution: Dissolve Sodium Iodide (1.5 eq) in dry Acetone (0.5 M).
- Addition: Add Phenethyl Bromide (1.0 eq) slowly at room temperature.
- Reaction: A white precipitate (NaBr) will form immediately. Stir for 1-2 hours.
- Workup: Filter off the NaBr solid. Concentrate the filtrate.
- Validation: Analyze via ^1H NMR. The -methylene triplet shifts upfield (from ~ 3.6 ppm for Br to ~ 3.3 ppm for I).

Decision Matrix for Researchers

Use the following logic flow to select the appropriate phenethyl halide for your application.

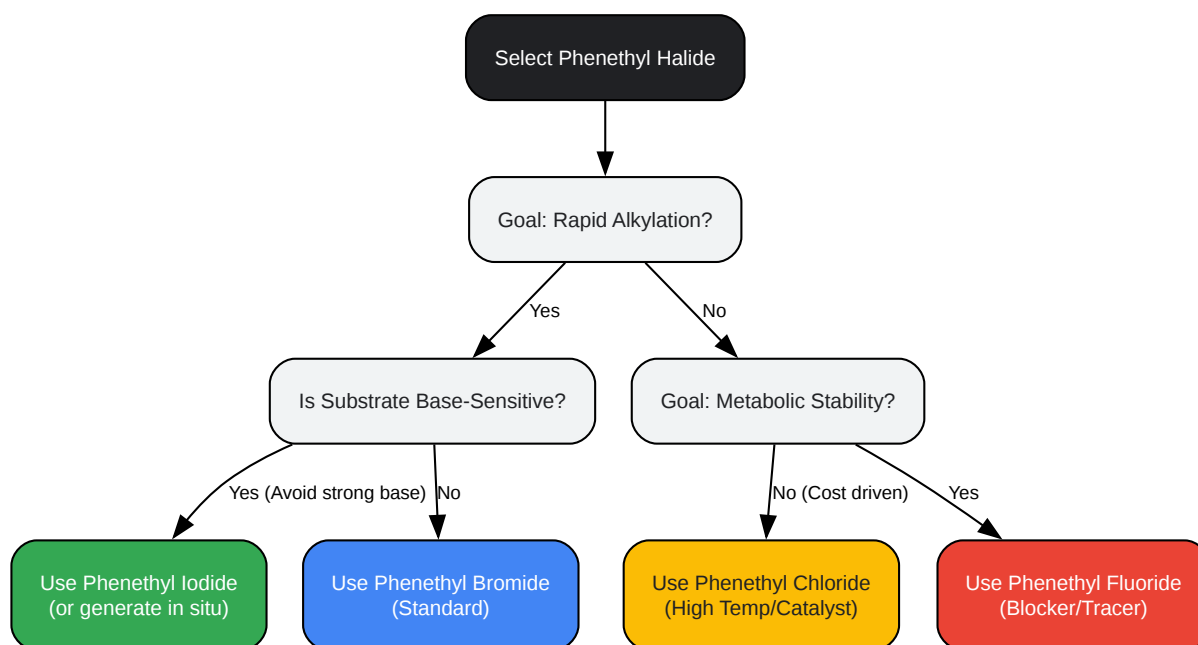

[Click to download full resolution via product page](#)

Figure 2: Selection logic for phenethyl halide substrates in synthesis.

References

- DePuy, C. H., & Bishop, C. A. (1960). Electronic Effects in Elimination Reactions. *Journal of the American Chemical Society*, 82(10), 2532–2535. [\[Link\]](#)
- Winstein, S., et al. (1952). Neighboring Carbon and Hydrogen.^[2] *Journal of the American Chemical Society*, 74(5), 1113–1120. [\[Link\]](#)
- Streitwieser, A. (1962). *Solvolytic Displacement Reactions*. McGraw-Hill.^[3] (Foundational text on solvolysis rates).
- Smith, M. B. (2013). *March's Advanced Organic Chemistry: Reactions, Mechanisms, and Structure*. Wiley. [\[Link\]](#)

Need Custom Synthesis?

BenchChem offers custom synthesis for rare earth carbides and specific isotopic labeling.

Email: info@benchchem.com or [Request Quote Online](#).

Sources

- [1. 8.3. Factors affecting rate of nucleophilic substitution reactions | Organic Chemistry 1: An open textbook \[courses.lumenlearning.com\]](#)
- [2. orgosolver.com \[orgosolver.com\]](#)
- [3. m.youtube.com \[m.youtube.com\]](#)
- To cite this document: BenchChem. [Comparative Study of Leaving Group Potential in Phenethyl Halides]. BenchChem, [2026]. [Online PDF]. Available at: [\[https://www.benchchem.com/product/b1288316/docs#comparative-study-of-leaving-group-potential-in-phenethyl-halides\]](https://www.benchchem.com/product/b1288316/docs#comparative-study-of-leaving-group-potential-in-phenethyl-halides)

Disclaimer & Data Validity:

The information provided in this document is for Research Use Only (RUO) and is strictly not intended for diagnostic or therapeutic procedures. While BenchChem strives to provide

accurate protocols, we make no warranties, express or implied, regarding the fitness of this product for every specific experimental setup.

Technical Support: The protocols provided are for reference purposes. Unsure if this reagent suits your experiment?

Need Industrial/Bulk Grade? [Request Custom Synthesis Quote](#)

BenchChem

Our mission is to be the trusted global source of essential and advanced chemicals, empowering scientists and researchers to drive progress in science and industry.

Contact

Address: 3281 E Guasti Rd

Ontario, CA 91761, United States

Phone: (601) 213-4426

Email: info@benchchem.com

[Contact our Ph.D. Support Team for a compatibility check](#)