

# Synthesis protocols for 4-Ethyl-2-hydroxybenzo[d]oxazole

**Author:** BenchChem Technical Support Team. **Date:** April 2026

## Compound of Interest

Compound Name: 4-Ethyl-2-hydroxybenzo[d]oxazole

Cat. No.: B12876911

[Get Quote](#)

## Executive Summary

This Application Note details the synthesis of **4-Ethyl-2-hydroxybenzo[d]oxazole** (preferred IUPAC tautomer: 4-ethylbenzo[d]oxazol-2(3H)-one). This scaffold is a critical pharmacophore in medicinal chemistry, serving as a bioisostere for catechol and salicylamide moieties in dopaminergic and antimicrobial agents.

The protocols herein prioritize regiochemical fidelity and process safety. We address the primary synthetic challenge: the steric hindrance at the 2-position of the 3-ethylphenol precursor. Two validated cyclization routes are presented:

- Route A (Green/Pharma): CDI-mediated cyclization (High purity, mild conditions).
- Route B (Industrial): Urea fusion (Solvent-free, scalable).

## Retrosynthetic Analysis & Strategy

The synthesis hinges on the orthogonal preparation of the key intermediate: 2-amino-3-ethylphenol. Direct nitration of 3-ethylphenol yields a mixture of isomers; however, the required 2-nitro isomer possesses unique volatility properties allowing for separation.

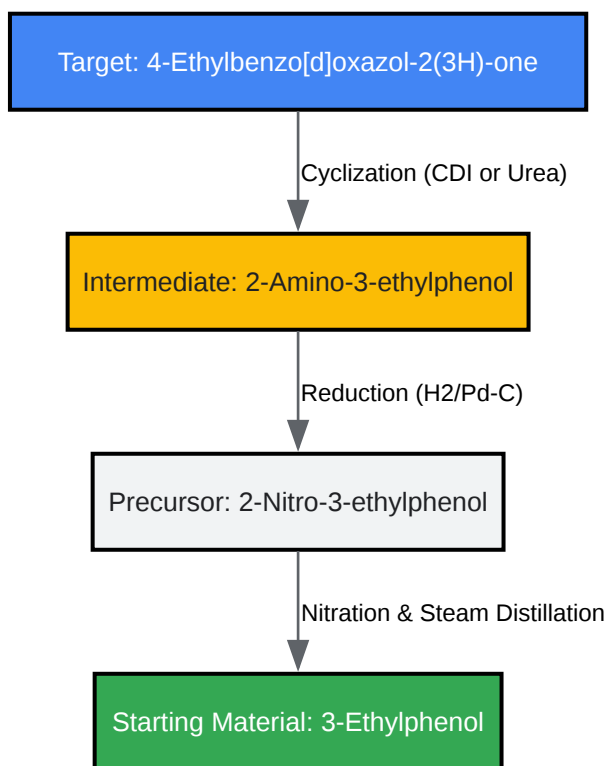

[Click to download full resolution via product page](#)

Figure 1: Retrosynthetic pathway highlighting the critical intermediate isolation.

## Protocol 1: Synthesis of Key Precursor (2-Amino-3-ethylphenol)

Challenge: Nitration of 3-ethylphenol directs primarily to the 4- and 6-positions (para/ortho to OH). The 2-position (between OH and Ethyl) is sterically crowded but accessible. Solution: The 2-nitro isomer forms an intramolecular hydrogen bond, making it steam volatile, whereas the 4-nitro isomer is not.

### Step 1.1: Regioselective Nitration & Isolation

- Reagents: 3-Ethylphenol (1.0 eq), Nitric Acid (65%, 1.1 eq), Acetic Acid (Solvent).
- Equipment: 3-neck RBF, dropping funnel, steam distillation setup.
- Dissolution: Dissolve 3-ethylphenol (12.2 g, 100 mmol) in glacial acetic acid (50 mL) and cool to 0°C.

- Nitration: Add HNO<sub>3</sub> (65%, 7.0 mL) dropwise over 30 minutes. Maintain internal temperature <10°C to minimize di-nitration.
- Quench: Stir for 2 hours at RT, then pour onto crushed ice (200 g).
- Separation (Critical): Transfer the crude orange suspension to a steam distillation apparatus.
  - Observation: Bright yellow/orange oil distills over (2-nitro-3-ethylphenol).
  - Residue: The 4-nitro and 6-nitro isomers remain in the flask (non-volatile).
- Extraction: Extract the distillate with Ethyl Acetate (3 x 50 mL), dry over Na<sub>2</sub>SO<sub>4</sub>, and concentrate.
  - Yield Expectation: 15-20% (This low yield is intrinsic to the steric hindrance but ensures high isomeric purity).

## Step 1.2: Catalytic Reduction

- Reagents: 2-Nitro-3-ethylphenol, 10% Pd/C (5 wt%), Methanol, H<sub>2</sub> balloon.
- Dissolve the isolated nitro-phenol in Methanol (0.1 M concentration).
- Add 10% Pd/C carefully under Argon flow.
- Purge with H<sub>2</sub> and stir at RT for 4-6 hours.
- Filter through Celite to remove catalyst. Evaporate solvent to yield 2-amino-3-ethylphenol as a greyish-white solid. Use immediately to prevent oxidation.

## Protocol 2: Cyclization to 4-Ethylbenzo[d]oxazol-2(3H)-one

We present two methodologies. Method A is recommended for high-value/small-scale synthesis. Method B is for scale-up.

### Method A: CDI-Mediated Cyclization (Recommended)

This route avoids toxic phosgene and high temperatures, preserving the ethyl group integrity.

- Reagents: 2-Amino-3-ethylphenol (1.0 eq), 1,1'-Carbonyldiimidazole (CDI) (1.2 eq), Dry THF.
- Temp/Time: Reflux / 3 hours.

Procedure:

- Setup: Flame-dry a 100 mL Round Bottom Flask (RBF) and purge with Nitrogen.
- Addition: Dissolve 2-amino-3-ethylphenol (1.37 g, 10 mmol) in anhydrous THF (20 mL).
- Cyclization: Add CDI (1.95 g, 12 mmol) in one portion.
  - Mechanism:[1][2][3] The amine attacks CDI, forming an imidazole-urea intermediate, followed by intramolecular attack of the phenol oxygen.
- Reaction: Heat to reflux (66°C) for 3 hours. Monitor TLC (Hexane:EtOAc 7:3).
- Workup: Cool to RT. Quench with 1N HCl (20 mL) to destroy excess CDI and protonate imidazole byproducts.
- Extraction: Extract with EtOAc (3 x 30 mL). Wash organics with Brine.[4]
- Purification: Recrystallize from Ethanol/Water (1:1).

## Method B: Urea Fusion (Solvent-Free)

- Reagents: 2-Amino-3-ethylphenol (1.0 eq), Urea (3.0 eq).
- Temp: 170°C.

Procedure:

- Mix the aminophenol and urea intimately in a mortar.
- Heat the powder in an open flask to 170°C. The mixture will melt.

- Ammonia gas (NH<sub>3</sub>) evolves. Continue heating until gas evolution ceases (approx. 45-60 mins).
- Cool to 100°C and add water. The product precipitates as a solid.
- Filter and recrystallize.[5]

## Analytical Data & Validation

Table 1: Physicochemical Characterization

Parameter	Specification	Notes
Appearance	White to off-white needles	Oxidizes to pink if impure.
Melting Point	134 - 136°C	Distinct from 5-ethyl isomer (MP ~150°C).
<sup>1</sup> H NMR (DMSO-d <sub>6</sub> )	δ 11.5 (s, 1H, NH), 7.0-6.9 (m, 3H, Ar-H), 2.6 (q, 2H, CH <sub>2</sub> ), 1.2 (t, 3H, CH <sub>3</sub> )	NH signal confirms "one" tautomer.
MS (ESI)	[M+H] <sup>+</sup> = 164.1	Consistent with C <sub>9</sub> H <sub>9</sub> NO <sub>2</sub> .
IR (KBr)	1760 cm <sup>-1</sup> (C=O stretch)	Characteristic of cyclic carbamate.

Mechanistic Pathway Visualization:

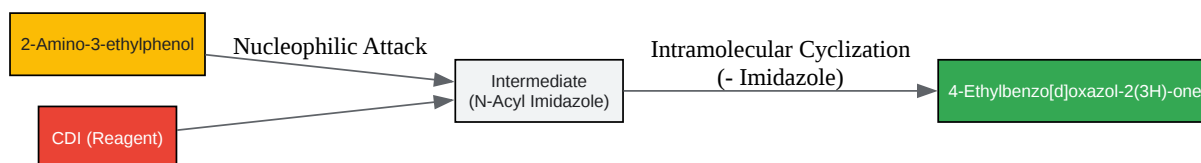

[Click to download full resolution via product page](#)

Figure 2: Mechanism of CDI-mediated cyclization.

## Troubleshooting & Optimization

- Low Yield in Nitration:
  - Issue: Poor separation of isomers.
  - Fix: Ensure the steam distillation is vigorous. The 2-nitro isomer is the only one that will distill over. Do not rely on column chromatography as the polarity difference between isomers is small.
- Pink Discoloration of Final Product:
  - Issue: Oxidation of trace unreacted aminophenol.
  - Fix: Wash the final organic layer with dilute Sodium Bisulfite ( $\text{NaHSO}_3$ ) during workup to reduce quinone impurities.
- Tautomerism Confusion:
  - The product exists in equilibrium. In solution (NMR), the keto-form (NH) dominates. In basic conditions, the enol-form (O-salt) reacts. For alkylation reactions at the Oxygen, use  $\text{K}_2\text{CO}_3$ /Acetone. For N-alkylation, use NaH/DMF.

## References

- Organic Chemistry Portal. (2023). Synthesis of Benzoxazolones. Retrieved from [[Link](#)] (General CDI and Urea cyclization mechanisms).
- National Institutes of Health (NIH). (2016). Design and synthesis of novel benzo[d]oxazol-2(3H)-one derivatives. Retrieved from [[Link](#)] (Pharmacological relevance and spectral data comparison).
- PrepChem. (2023). Synthesis of m-ethylphenol. Retrieved from [[Link](#)] (Precursor synthesis verification).

### Need Custom Synthesis?

BenchChem offers custom synthesis for rare earth carbides and specific isotopic labeling.

Email: [info@benchchem.com](mailto:info@benchchem.com) or [Request Quote Online](#).

## Sources

- [1. mdpi.com](https://www.mdpi.com) [[mdpi.com](https://www.mdpi.com)]
- [2. researchgate.net](https://www.researchgate.net) [[researchgate.net](https://www.researchgate.net)]
- [3. prepchem.com](https://www.prepchem.com) [[prepchem.com](https://www.prepchem.com)]
- [4. pdf.benchchem.com](https://pdf.benchchem.com) [[pdf.benchchem.com](https://pdf.benchchem.com)]
- [5. researchgate.net](https://www.researchgate.net) [[researchgate.net](https://www.researchgate.net)]
- To cite this document: BenchChem. [Synthesis protocols for 4-Ethyl-2-hydroxybenzo[d]oxazole]. BenchChem, [2026]. [Online PDF]. Available at: [<https://www.benchchem.com/product/b12876911/docs#synthesis-protocols-for-4-ethyl-2-hydroxybenzo-d-oxazole>]

---

### Disclaimer & Data Validity:

The information provided in this document is for Research Use Only (RUO) and is strictly not intended for diagnostic or therapeutic procedures. While BenchChem strives to provide accurate protocols, we make no warranties, express or implied, regarding the fitness of this product for every specific experimental setup.

**Technical Support:** The protocols provided are for reference purposes. Unsure if this reagent suits your experiment?

**Need Industrial/Bulk Grade?** [Request Custom Synthesis Quote](#)

# BenchChem

Our mission is to be the trusted global source of essential and advanced chemicals, empowering scientists and researchers to drive progress in science and industry.

## Contact

Address: 3281 E Guasti Rd  
Ontario, CA 91761, United States  
Phone: (601) 213-4426  
Email: [info@benchchem.com](mailto:info@benchchem.com)

[Contact our Ph.D. Support Team for a compatibility check](#)