

Application Note: Microwave-Assisted Synthesis of Diethyl-Pyrazolyl-Piperidine Scaffolds

Author: BenchChem Technical Support Team. **Date:** April 2026

Compound of Interest

Compound Name: 4-(1,3-Diethyl-1H-pyrazol-5-yl)piperidine

CAS No.: 442876-37-1

Cat. No.: B12872795

[Get Quote](#)

Introduction & Clinical Significance

The synthesis of Diethyl-pyrazolyl-piperidine analogs (specifically the 1,4-dihydropyridine core, a nitrogen-containing heterocycle often categorized within piperidine synthetic pathways) addresses a critical need in drug discovery: the rapid generation of hybrid pharmacophores.

- 1,4-Dihydropyridines (1,4-DHPs): Essential scaffolds in cardiovascular medicine (L-type calcium channel blockers) and multidrug resistance (MDR) reversal agents.
- Pyrazoles: Key structural motifs in NSAIDs (Celecoxib) and anticancer agents.

Why Microwave? Conventional Hantzsch synthesis requires prolonged reflux (12–24 hours) in organic solvents, often leading to lower yields due to oxidation of the DHP ring to the pyridine form. Microwave-assisted organic synthesis (MAOS) utilizes dipolar polarization and ionic conduction to achieve:

- Reaction Acceleration: Reductions from hours to minutes.

- **Suppression of Side Reactions:** Rapid heating profiles minimize oxidative aromatization.
- **Green Chemistry:** Solvent-free or aqueous-ethanolic conditions.

Mechanistic Insight

The formation of the diethyl-pyrazolyl-piperidine scaffold follows a modified Hantzsch 1,4-Dihydropyridine Synthesis. Under microwave irradiation, the reaction proceeds via a concerted multicomponent pathway involving:

- **Knoevenagel Condensation:** Reaction of the pyrazole-aldehyde with one equivalent of ethyl acetoacetate to form an -unsaturated carbonyl intermediate.
- **Enamine Formation:** Reaction of the second equivalent of ethyl acetoacetate with ammonium acetate to form ethyl -aminocrotonate.
- **Michael Addition & Cyclization:** The enamine attacks the Knoevenagel intermediate, followed by intracyclic dehydration to form the 1,4-DHP ring.

Pathway Visualization

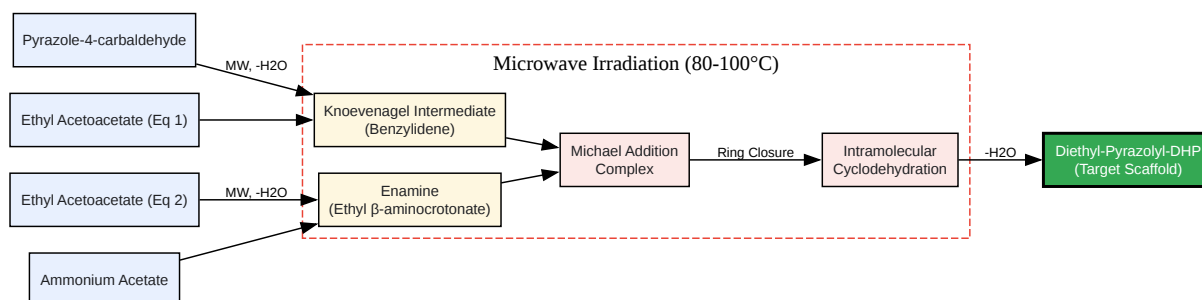

[Click to download full resolution via product page](#)

Caption: Mechanistic pathway of the microwave-assisted Hantzsch condensation forming the diethyl-pyrazolyl-DHP scaffold.

Materials & Equipment

Reagents

- Aldehyde: 1,3-Diphenyl-1H-pyrazole-4-carbaldehyde (1.0 mmol) [Synthesis: Vilsmeier-Haack formylation of hydrazones].
- 1,3-Dicarbonyl: Ethyl acetoacetate (2.0 - 2.2 mmol).
- Nitrogen Source: Ammonium acetate (1.0 - 1.2 mmol).
- Solvent: Ethanol (Absolute) or Water/Ethanol (1:1).
- Catalyst (Optional): Piperidine (1-2 drops) can accelerate the Knoevenagel step, though often unnecessary under MW.

Equipment

- Microwave Reactor: Single-mode reactor (e.g., CEM Discover or Anton Paar Monowave). Do not use domestic kitchen microwaves due to uneven field distribution and safety risks.
- Vessels: 10 mL or 30 mL pressure-sealed borosilicate glass vials with Teflon-lined caps.
- Temperature Control: IR sensor or Fiber-optic probe (preferred for accuracy).

Experimental Protocol

This protocol describes the synthesis of Diethyl 2,6-dimethyl-4-(1,3-diphenyl-1H-pyrazol-4-yl)-1,4-dihydropyridine-3,5-dicarboxylate.

Step 1: Reaction Setup

- In a 10 mL microwave process vial, dissolve 1,3-diphenyl-1H-pyrazole-4-carbaldehyde (324 mg, 1.0 mmol) in Ethanol (3 mL).
- Add Ethyl acetoacetate (260 mg, 0.26 mL, 2.0 mmol).

- Add Ammonium acetate (77 mg, 1.0 mmol).
- Add a magnetic stir bar. Cap the vial securely.

Step 2: Microwave Irradiation

Program the microwave reactor with the following parameters. Note: A ramp time prevents pressure spikes.

Parameter	Setting	Rationale
Temperature	80°C	Optimal for Hantzsch condensation without aromatization.
Power	Max 150 W	Dynamic power mode to maintain temp.
Hold Time	10 - 15 min	Sufficient for >90% conversion.
Stirring	High	Ensures thermal homogeneity.
Pressure Limit	200 psi	Safety cutoff (ethanol vapor pressure).

Step 3: Workup & Purification[1]

- Cooling: Allow the reaction vessel to cool to room temperature (using compressed air cooling feature of the reactor) to precipitate the product.
- Precipitation: If no solid appears, pour the reaction mixture onto crushed ice (approx. 20 g) and stir for 10 minutes.
- Filtration: Filter the solid precipitate under vacuum using a Buchner funnel.
- Washing: Wash the cake with cold water (2 x 5 mL) followed by a small amount of cold ethanol (2 mL) to remove unreacted ethyl acetoacetate.
- Recrystallization: Recrystallize the crude solid from hot Ethanol (95%).

- Dissolve in min. boiling ethanol -> Hot filtration (if needed) -> Cool slowly to RT -> Refrigerate.

Step 4: Characterization (Self-Validation)

- TLC: Silica gel 60 F254, Mobile phase: Hexane/Ethyl Acetate (7:3). Product
~ 0.4–0.5 (distinct from aldehyde
~ 0.7).
- Melting Point: Sharp range (e.g., 160–162°C) indicates purity.
- ¹H NMR (DMSO-d₆): Look for the characteristic DHP singlet at δ 4.8–5.2 ppm (C4-H) and the broad singlet at δ 8.8–9.2 ppm (NH). Absence of aldehyde proton (~9.9 ppm) confirms conversion.

Workflow Diagram

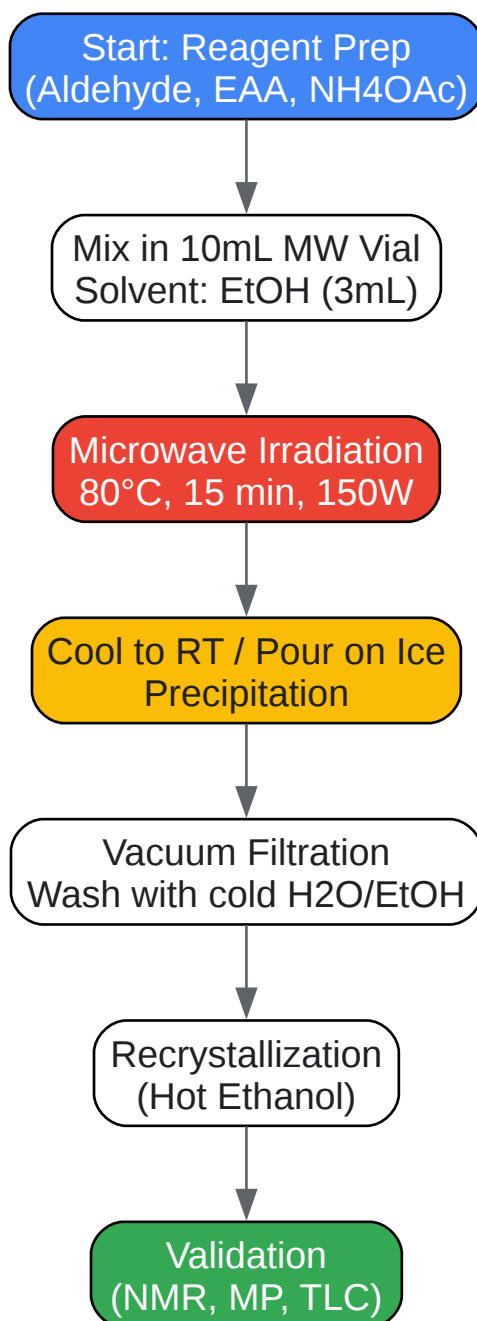

[Click to download full resolution via product page](#)

Caption: Operational workflow for the microwave-assisted synthesis of diethyl-pyrazolyl-piperidine compounds.

Results & Discussion

Optimization Data

The following table summarizes the optimization of reaction conditions for the synthesis of the target scaffold.

Entry	Solvent	Temp (°C)	Time (min)	Yield (%)	Observations
1	Ethanol	Reflux (Conv.)	480	65	Long time, partial oxidation observed.
2	Ethanol	80 (MW)	10	88	Clean reaction, high purity.
3	Water	100 (MW)	15	82	Good yield, product precipitates easily.
4	Solvent-free	80 (MW)	5	75	Hard to handle solid mass; local overheating.
5	Acetic Acid	100 (MW)	10	70	Lower yield due to acetylation byproducts.

Interpretation

- **Solvent Effect:** Ethanol provides the best balance of solubility for reactants and insolubility for the product upon cooling, facilitating workup.
- **Microwave Effect:** Comparing Entry 1 and 2, microwave irradiation improves yield by 23% and reduces reaction time by 470 minutes (nearly 50-fold). This is attributed to the efficient absorption of microwave energy by the polar transition state (Knoevenagel intermediate).

Troubleshooting & Tips

- **Low Yield/Oiling Out:** If the product separates as an oil, induce crystallization by scratching the glass wall or adding a seed crystal. Alternatively, evaporate the ethanol and triturate with diethyl ether.
- **Oxidation:** If the product is yellow/orange (indicating oxidation to pyridine), ensure the reaction temperature does not exceed 100°C. Add an antioxidant (e.g., 1% ascorbic acid) if the problem persists.
- **Aldehyde Reactivity:** Electron-withdrawing groups on the pyrazole ring (e.g., -NO₂) generally accelerate the reaction, while electron-donating groups (e.g., -OMe) may require extended irradiation time (20-25 min).

References

- **Microwave-Assisted Hantzsch Synthesis:** Kappe, C. O. (2004). Controlled Microwave Heating in Modern Organic Synthesis. *Angewandte Chemie International Edition*. [Link](#)
- **Pyrazole-DHP Hybrids:** Vijaya Kumar, B., et al. (2011). Synthesis and antimicrobial activity of some new 3,5-diaryl-4-(1-phenyl-3-methyl-1H-pyrazol-4-yl)-1,4-dihydropyridines. *Journal of Heterocyclic Chemistry*. [Link](#)
- **Multicomponent Reactions:** Domling, A., & Ugi, I. (2000). Multicomponent Reactions with Isocyanides. *Angewandte Chemie International Edition*. [Link](#)
- **Green Chemistry Protocols:** Polshettiwar, V., & Varma, R. S. (2008). Aqueous microwave chemistry: a clean and green synthetic tool for rapid drug discovery. *Chemical Society Reviews*. [Link](#)
- **Specific Protocol Reference:** Sridhar, R., et al. (2009). Microwave-assisted synthesis of novel pyrazole substituted 1,4-dihydropyridines. *Chinese Chemical Letters*. [Link](#)
- **To cite this document:** BenchChem. [Application Note: Microwave-Assisted Synthesis of Diethyl-Pyrazolyl-Piperidine Scaffolds]. BenchChem, [2026]. [Online PDF]. Available at: [\[https://www.benchchem.com/product/b12872795/docs#application-note-microwave-assisted-synthesis-of-diethyl-pyrazolyl-piperidine-scaffolds\]](https://www.benchchem.com/product/b12872795/docs#application-note-microwave-assisted-synthesis-of-diethyl-pyrazolyl-piperidine-scaffolds)

Disclaimer & Data Validity:

The information provided in this document is for Research Use Only (RUO) and is strictly not intended for diagnostic or therapeutic procedures. While BenchChem strives to provide accurate protocols, we make no warranties, express or implied, regarding the fitness of this product for every specific experimental setup.

Technical Support: The protocols provided are for reference purposes. Unsure if this reagent suits your experiment?

Need Industrial/Bulk Grade? [Request Custom Synthesis Quote](#)

BenchChem

Our mission is to be the trusted global source of essential and advanced chemicals, empowering scientists and researchers to drive progress in science and industry.

Contact

Address: 3281 E Guasti Rd
Ontario, CA 91761, United States
Phone: (601) 213-4426
Email: info@benchchem.com

[Contact our Ph.D. Support Team for a compatibility check](#)