

electronic structure of fluorene-based hole transport materials

Author: BenchChem Technical Support Team. **Date:** May 2026

Compound of Interest

Compound Name: *N-([1,1'-Biphenyl]-4-yl)-9,9-dimethyl-9H-fluoren-2-amine*

CAS No.: 897671-69-1

Cat. No.: B1287010

[Get Quote](#)

An In-depth Technical Guide to the Electronic Structure of Fluorene-Based Hole Transport Materials

Introduction

Fluorene-based compounds have emerged as a highly promising class of organic semiconductors, particularly for their application as hole transport materials (HTMs) in advanced electronic devices such as perovskite solar cells (PSCs) and organic light-emitting diodes (OLEDs). Their rigid, planar, and highly conjugated structure provides a robust molecular core that facilitates efficient charge transport. The C9 position of the fluorene unit can be readily functionalized, typically with alkyl chains, to enhance solubility and prevent intermolecular aggregation, which is crucial for forming high-quality, amorphous thin films.^[1]

The performance of these devices is intrinsically linked to the electronic properties of the HTM. Key parameters include the energy levels of the Highest Occupied Molecular Orbital (HOMO) and Lowest Unoccupied Molecular Orbital (LUMO), charge carrier mobility, and thermal stability. These properties dictate the efficiency of hole injection from the active layer (e.g.,

perovskite) to the HTM, the subsequent transport of these holes to the electrode, and the overall longevity of the device.[2][3] This guide provides a detailed overview of the core electronic structure of fluorene-based HTMs, the experimental methods used for their characterization, and a summary of key performance data.

Core Electronic Properties and Their Significance

The electronic structure of an HTM governs its function within an optoelectronic device. The primary role of the HTM is to efficiently extract photogenerated holes from the light-absorbing layer and transport them to the anode, while simultaneously blocking electron passage, thereby minimizing charge recombination.

- **HOMO and LUMO Energy Levels:** The HOMO level is of paramount importance as it determines the energy barrier for hole extraction from the adjacent active layer. For efficient hole transfer, the HOMO level of the HTM should be slightly shallower than (i.e., higher in energy than) the valence band maximum of the perovskite or the HOMO of the emissive material in an OLED.[1][2] The LUMO level is also critical; it should be sufficiently high to create a large energy barrier for electrons, effectively blocking them from reaching the anode and causing recombination losses.[1] The energy difference between the HOMO and LUMO levels defines the material's electrochemical band gap.
- **Charge Carrier Mobility:** High hole mobility is essential for rapid and efficient charge transport through the HTM layer. A higher mobility reduces the transit time of holes, decreasing the probability of them recombining with electrons before being collected at the electrode. This directly contributes to higher short-circuit currents and overall device efficiency.[2][4] Fluorene-based materials can exhibit hole mobilities in the range of 10^{-5} to 10^{-3} $\text{cm}^2 \text{V}^{-1} \text{s}^{-1}$. [4][5][6]
- **Thermal Stability:** The operational stability and lifetime of organic electronic devices are heavily dependent on the thermal properties of the constituent materials. A high glass transition temperature (T_g) and decomposition temperature (T_{dec}) are indicative of a morphologically and chemically stable material that can withstand the operating temperatures and fabrication processes without degradation.[1][7]

Data Presentation: Electronic Properties of Fluorene-Based HTMs

The following table summarizes key electronic and thermal properties for a selection of fluorene-based hole transport materials discussed in the literature.

Material Abbreviation	HOMO (eV)	LUMO (eV)	Hole Mobility (μ) ($\text{cm}^2 \text{V}^{-1} \text{s}^{-1}$)	Tg ($^{\circ}\text{C}$)	Tdec ($^{\circ}\text{C}$)	Reference
Spiro-OMeTAD (Reference)	-5.17 to -5.22	-2.05 to -2.28	1×10^{-4} to 5×10^{-5}	121	410	[6][8]
X55	-5.21	-2.05	1.9×10^{-4}	191	450	[9]
V1498	-5.35	-2.15	1.8×10^{-5} (cross-linked)	104	395	[7]
V1499	-5.39	-2.24	2.5×10^{-5} (cross-linked)	125	410	[7]
DDF	-5.25	-2.15	2.35×10^{-4}	N/A	319	[1]
2M-DDF	-5.19	-2.09	4.65×10^{-4}	N/A	329	[1][6]
4M-DDF	-5.12	-2.02	1.55×10^{-4}	N/A	327	[1]
spiro-CZ	-5.51	-2.43	N/A	165	400	[10]
spiro-TPA	-5.39	-2.41	N/A	162	416	[10]
V1	-5.14	-2.15	N/A	N/A	N/A	[3]
V2	-5.26	-2.19	N/A	N/A	N/A	[3]

Note: Values can vary slightly between different reports due to variations in measurement conditions and techniques.

Experimental Protocols

Accurate determination of the electronic properties of HTMs is crucial for predicting their performance and for rational material design. The following are standard experimental protocols for key characterization techniques.

Cyclic Voltammetry (CV) for HOMO/LUMO Level Estimation

Cyclic voltammetry is an electrochemical technique used to probe the redox properties of a material, from which the HOMO and LUMO energy levels can be estimated.^[11]

- Principle: The material is dissolved in a solution and subjected to a linearly swept potential. The potential at which the material is oxidized corresponds to the removal of an electron from its HOMO, and the potential at which it is reduced corresponds to the addition of an electron to its LUMO. By referencing these potentials to a known standard, typically the ferrocene/ferrocenium (Fc/Fc⁺) redox couple, the absolute energy levels can be calculated.^{[12][13]}
- Experimental Setup:
 - Three-Electrode Cell: A standard three-electrode electrochemical cell is used, containing a working electrode (e.g., glassy carbon or platinum), a reference electrode (e.g., Ag/AgCl or a silver wire pseudo-reference), and a counter electrode (e.g., platinum wire).^[14]
 - Electrolyte Solution: The fluorene-based HTM is dissolved at a low concentration (e.g., 1 mM) in an appropriate solvent (e.g., dichloromethane, acetonitrile) containing a supporting electrolyte (e.g., 0.1 M tetrabutylammonium hexafluorophosphate, TBAPF₆). The solution must be deoxygenated by bubbling with an inert gas like nitrogen or argon.
 - Measurement: The potential is swept, and the resulting current is measured. After the measurement of the sample, a small amount of ferrocene is added to the solution, and the measurement is repeated to determine the E_{1/2} of the Fc/Fc⁺ couple under the same conditions.

- Data Analysis:
 - The onset oxidation potential ($E_{\text{onset,ox}}$) and onset reduction potential ($E_{\text{onset,red}}$) are determined from the voltammogram.
 - The HOMO and LUMO energy levels are calculated using the following empirical formulas:[12]
 - $E_{\text{HOMO}} \text{ (eV)} = -[E_{\text{onset,ox}} \text{ (vs Fc/Fc}^+) + E_{\text{ref}}]$
 - $E_{\text{LUMO}} \text{ (eV)} = -[E_{\text{onset,red}} \text{ (vs Fc/Fc}^+) + E_{\text{ref}}]$
 - Where E_{ref} is the absolute energy level of the Fc/Fc⁺ reference, commonly taken as 4.8 eV or 5.1 eV below the vacuum level.[13]

Ultraviolet Photoelectron Spectroscopy (UPS) for Ionization Potential (HOMO) Measurement

UPS is a surface-sensitive technique that directly measures the electronic density of states of a material's valence band, providing a precise value for the ionization potential, which corresponds to the HOMO level.[15][16]

- Principle: The material, prepared as a thin film on a conductive substrate, is irradiated with a monochromatic source of ultraviolet photons (typically He I at 21.22 eV). The photons cause the ejection of valence electrons (photoelectric effect). By measuring the kinetic energy (E_{k}) of these emitted electrons, their binding energy (E_{b}) relative to the Fermi level can be determined using the equation: $E_{\text{b}} = h\nu - E_{\text{k}} - W_{\text{sp}}$, where $h\nu$ is the photon energy and W_{sp} is the spectrometer work function.
- Experimental Setup:
 - UHV System: The experiment is conducted in an ultra-high vacuum (UHV) chamber (pressure $< 10^{-9}$ Torr) to prevent surface contamination and scattering of electrons.
 - Sample Preparation: A thin film of the fluorene-based material is deposited on a conductive substrate (e.g., indium tin oxide (ITO) or gold).

- Instrumentation: The setup consists of a UV photon source (e.g., a helium discharge lamp) and a hemispherical electron energy analyzer to measure the kinetic energy distribution of the photoemitted electrons. A bias is applied to the sample to separate the sample and analyzer secondary electron cutoffs.
- Data Analysis:
 - HOMO Level: The HOMO level is determined from the intersection of the tangent of the leading edge of the valence band spectrum with the background signal. This value represents the energy of the highest occupied states relative to the Fermi level.
 - Work Function (Φ): The sample's work function is determined from the secondary electron cutoff (SEC) region of the spectrum using the equation: $\Phi = h\nu - (E_{k,cutoff} - E_{k,Fermi})$.

Time-of-Flight (TOF) for Hole Mobility Measurement

The TOF technique is a direct method for measuring the charge carrier mobility in a semiconductor.^{[4][17]}

- Principle: A thin film of the material is sandwiched between two electrodes. A short, intense pulse of light with energy greater than the material's band gap creates a sheet of electron-hole pairs near one of the electrodes. An applied electric field separates these charges, and one type of carrier (holes, in this case) drifts across the sample's thickness (d) to the collecting electrode. The time it takes for the carriers to traverse the sample (the transit time, t_T) is measured from the resulting photocurrent transient.
- Experimental Setup:
 - Sample Structure: A "sandwich" device is fabricated, typically with the structure ITO / HTM / Al. The thickness of the HTM layer (d) must be accurately known (typically several micrometers).
 - Instrumentation: The sample is placed in a cryostat under vacuum. A pulsed nitrogen laser (e.g., 337 nm) is used to generate the charge carriers. A DC voltage source applies a bias (V) across the device, and a fast oscilloscope records the transient photocurrent.
- Data Analysis:

- The photocurrent transient is plotted. For non-dispersive transport, the transient will show an initial spike followed by a plateau and then a drop-off. The transit time (t_T) is identified as the "knee" in a linear plot or the inflection point in a log-log plot of current vs. time.
- The hole mobility (μ) is calculated using the formula:
 - $\mu = d^2 / (V * t_T)$
- Measurements are typically performed at various applied fields and temperatures to study the field and temperature dependence of the mobility.

Mandatory Visualizations

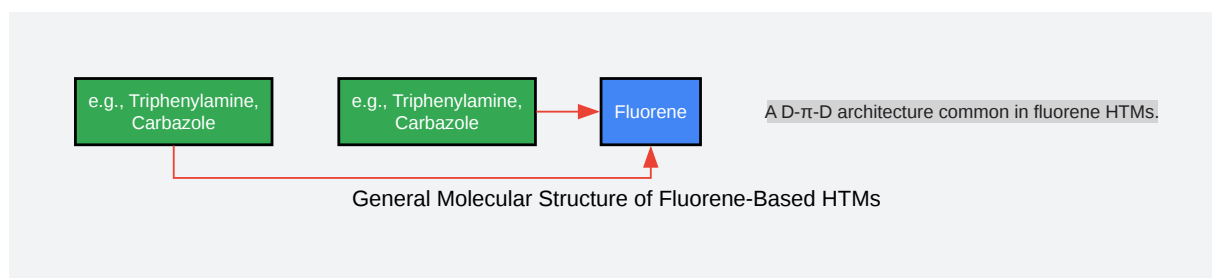

[Click to download full resolution via product page](#)

Caption: A D- π -D architecture common in fluorene HTMs.

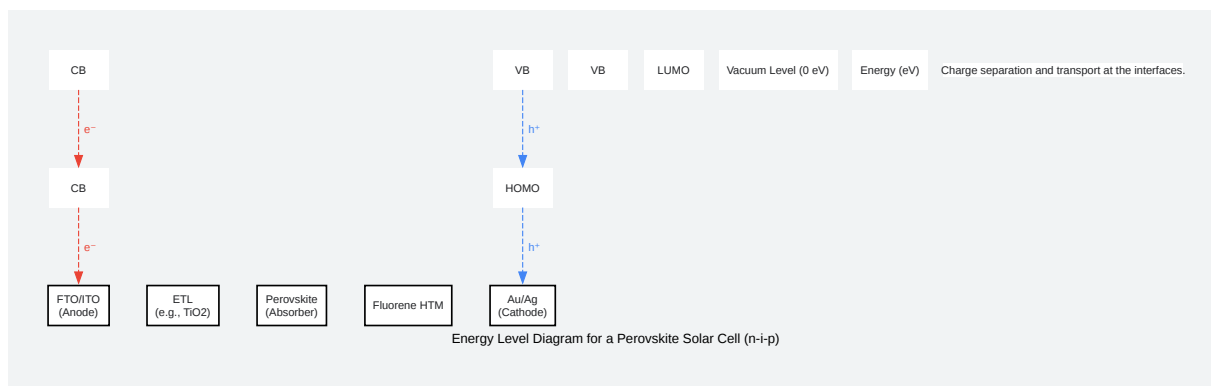

[Click to download full resolution via product page](#)

Caption: Charge separation and transport at the interfaces.

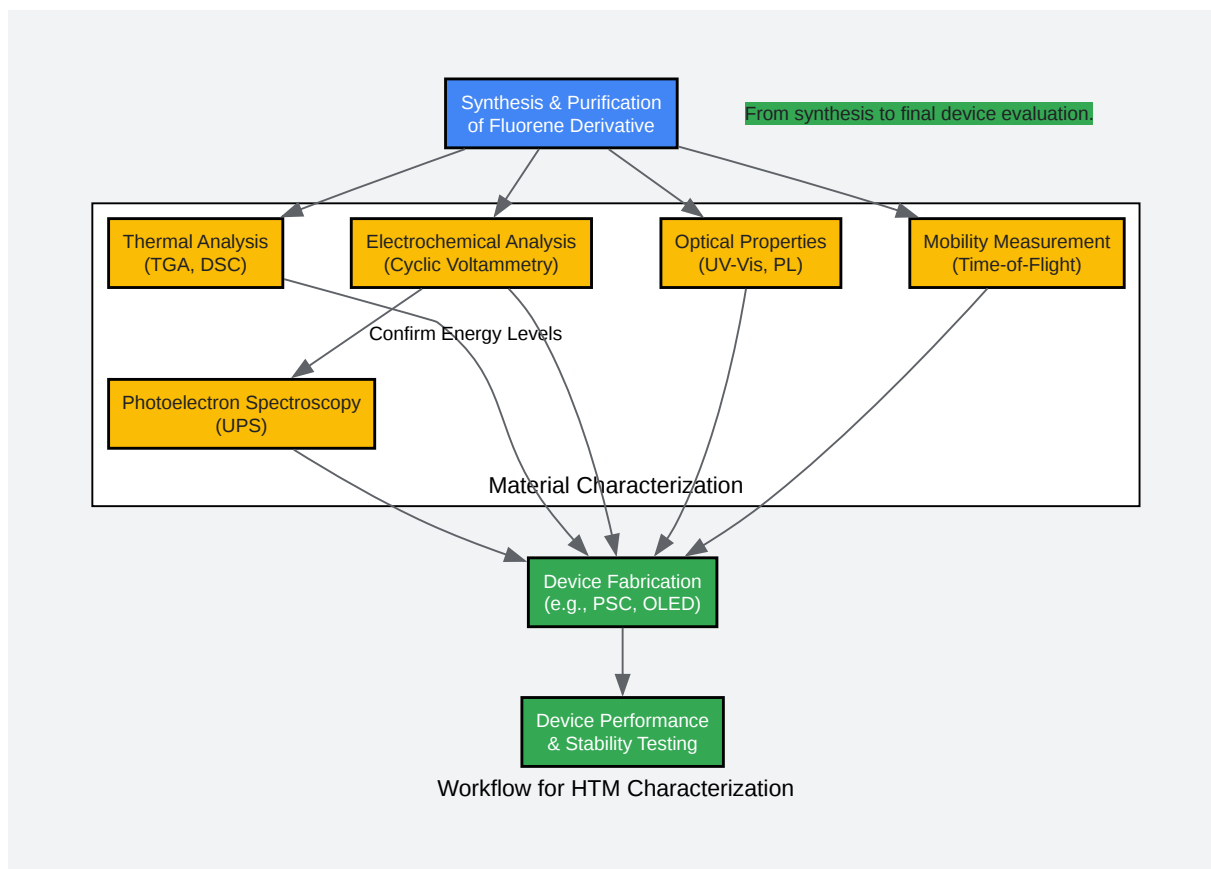

[Click to download full resolution via product page](#)

Caption: From synthesis to final device evaluation.

Conclusion

The electronic structure of fluorene-based hole transport materials is a critical determinant of their performance in optoelectronic devices. The strategic design of these molecules, often following a D- π -D architecture, allows for the fine-tuning of HOMO/LUMO energy levels to ensure efficient hole extraction and electron blocking.[3] Techniques such as cyclic voltammetry and ultraviolet photoelectron spectroscopy are indispensable for accurately determining these

energy levels, while the time-of-flight method provides direct measurement of charge carrier mobility. By understanding and controlling these fundamental electronic properties through rational molecular design and verifying them with robust experimental protocols, researchers can develop next-generation fluorene-based HTMs that push the efficiency and stability of perovskite solar cells, OLEDs, and other organic electronic technologies to new heights.

Need Custom Synthesis?

BenchChem offers custom synthesis for rare earth carbides and specific isotopic labeling.

Email: info@benchchem.com or [Request Quote Online](#).

References

- [1. mdpi.com \[mdpi.com\]](https://www.mdpi.com)
- [2. pubs.acs.org \[pubs.acs.org\]](https://pubs.acs.org)
- [3. Dopant-free hydrophobic fluorene-based hole transport materials: impact of methoxy-substituted triphenylamine and carbazole peripheral groups on the performance of perovskite solar cells - Sustainable Energy & Fuels \(RSC Publishing\) \[pubs.rsc.org\]](#)
- [4. New fluorene-based bipolar charge transporting materials - PMC \[pmc.ncbi.nlm.nih.gov\]](#)
- [5. researchgate.net \[researchgate.net\]](https://www.researchgate.net)
- [6. Hole-Transporting Materials Based on a Fluorene Unit for Efficient Optoelectronic Devices - PMC \[pmc.ncbi.nlm.nih.gov\]](#)
- [7. Thermally cross-linkable fluorene-based hole transporting materials: synthesis, characterization, and application in perovskite solar cells - PMC \[pmc.ncbi.nlm.nih.gov\]](#)
- [8. researchgate.net \[researchgate.net\]](https://www.researchgate.net)
- [9. researchgate.net \[researchgate.net\]](https://www.researchgate.net)
- [10. Facile fluorene-based hole-transporting materials and their dual application toward inverted and regular perovskite solar cells - Sustainable Energy & Fuels \(RSC Publishing\) \[pubs.rsc.org\]](#)
- [11. researchgate.net \[researchgate.net\]](https://www.researchgate.net)
- [12. prezi.com \[prezi.com\]](https://prezi.com)
- [13. researchgate.net \[researchgate.net\]](https://www.researchgate.net)

- [14. CN102928480A - Method for determining LUMO value and HOMO value of semiconductor nano-crystals through utilizing cyclic voltammetry - Google Patents \[patents.google.com\]](#)
- [15. researchgate.net \[researchgate.net\]](#)
- [16. Ultraviolet Photoelectron Spectroscopy | Materials Research Institute \[mri.psu.edu\]](#)
- [17. researchgate.net \[researchgate.net\]](#)
- To cite this document: BenchChem. [electronic structure of fluorene-based hole transport materials]. BenchChem, [2026]. [Online PDF]. Available at: [\[https://www.benchchem.com/product/b1287010/docs#electronic-structure-of-fluorene-based-hole-transport-materials\]](https://www.benchchem.com/product/b1287010/docs#electronic-structure-of-fluorene-based-hole-transport-materials)

Disclaimer & Data Validity:

The information provided in this document is for Research Use Only (RUO) and is strictly not intended for diagnostic or therapeutic procedures. While BenchChem strives to provide accurate protocols, we make no warranties, express or implied, regarding the fitness of this product for every specific experimental setup.

Technical Support: The protocols provided are for reference purposes. Unsure if this reagent suits your experiment?

Need Industrial/Bulk Grade? [Request Custom Synthesis Quote](#)

BenchChem

Our mission is to be the trusted global source of essential and advanced chemicals, empowering scientists and researchers to drive progress in science and industry.

Contact

Address: 3281 E Guasti Rd
Ontario, CA 91761, United States
Phone: (601) 213-4426
Email: info@benchchem.com

Contact our Ph.D. Support Team for a compatibility check