

# Comparative Efficacy Guide: Pyrazole-Based Insecticides vs. Commercial Standards

**Author:** BenchChem Technical Support Team. **Date:** May 2026

## Compound of Interest

Compound Name: *4-(chloromethyl)-1-methyl-1H-pyrazole*

CAS No.: 735241-98-2

Cat. No.: B1287666

[Get Quote](#)

## Executive Summary

The phase-out of organophosphates and the rising resistance to pyrethroids (kdr mutations) have necessitated the development of novel chemotypes. Pyrazole-based insecticides—specifically phenylpyrazoles (e.g., Fipronil) and pyrazole-5-carboxamides (e.g., Tolfenpyrad)—offer distinct modes of action (MoA) that circumvent cross-resistance.

This guide provides a technical comparison of these pyrazole subclasses against established standards (Cypermethrin, Chlorpyrifos, and Indoxacarb). It details the mechanistic divergence, validates a standardized leaf-dip bioassay protocol, and presents quantitative efficacy data to support lead optimization in drug development pipelines.

## Mechanistic Basis & Target Specificity[1]

To engineer superior molecules, one must understand the target site causality. Pyrazoles function through two primary, distinct mechanisms depending on their structural subclass.

## Phenylpyrazoles (The Fipronil Class)[2][3][4]

- Primary Target:
  - Aminobutyric acid (GABA)-gated chloride channels.[1]
- Secondary Target: Glutamate-gated chloride channels (GluCl<sub>s</sub>).[2]
- Mechanism: Non-competitive antagonism.[3] They bind to the channel pore, blocking Cl<sup>-</sup> influx. This prevents hyperpolarization, leading to hyperexcitation and convulsions.
- Selectivity: The high affinity for insect GluCl<sub>s</sub> (absent in mammals) provides a safety margin, though environmental persistence remains a concern.

## Pyrazole-5-carboxamides (The Tolfenpyrad Class)[6]

- Target: Complex I (NADH:ubiquinone oxidoreductase) of the mitochondrial electron transport chain.
- Mechanism: Inhibits ATP synthesis, causing energy failure and cellular respiration collapse.

## Pathway Visualization

The following diagram illustrates the divergent pathways of Pyrazole subclasses compared to Pyrethroids (Na<sup>+</sup> channel modulators).

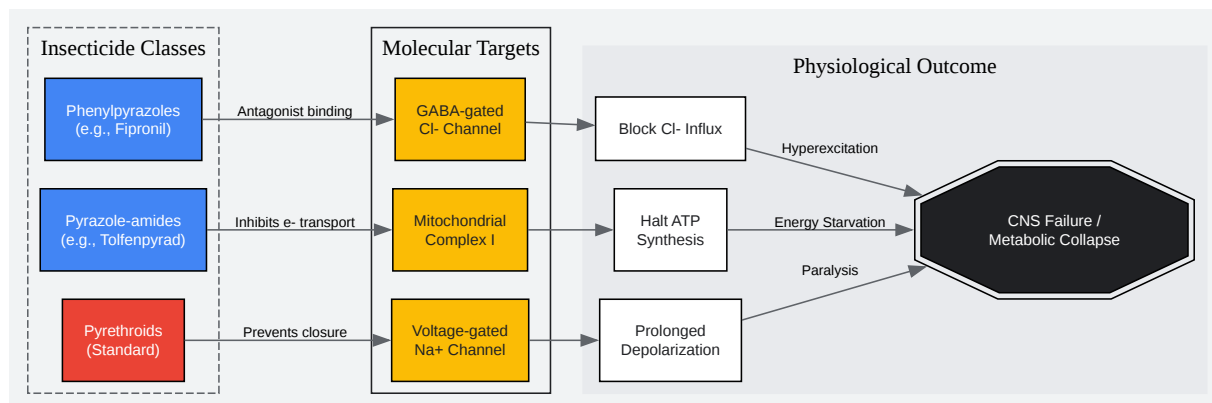

[Click to download full resolution via product page](#)

Caption: Figure 1.[4] Distinct Modes of Action (MoA) for Pyrazole subclasses vs. Pyrethroid standards.

## Experimental Validation: Standardized Bioassay Protocol

Reliable LC50 data depends on a self-validating protocol. The Leaf-Dip Method (adapted from IRAC Method No. 7) is the industry standard for contact/stomach efficacy in Lepidoptera and Coleoptera.

### Reagents & Preparation

- Solvent System: Acetone:Water (50:50) or 0.1% Triton X-100/Tween 80 in distilled water (to ensure wetting).
- Test Organism: 3rd instar larvae (e.g., *Plutella xylostella* or *Spodoptera litura*).[5] Uniform age is critical to reduce variability.
- Control: Solvent-only solution.

## Step-by-Step Workflow

This protocol includes mandatory "Checkpoints" to ensure data integrity.

- Stock Preparation: Dissolve technical grade pyrazole (e.g., Compound 7g or Fipronil) in acetone to create a 10,000 ppm stock.
- Serial Dilution: Prepare 5-7 concentrations (logarithmic scale) to bracket the expected LC50.
- Dipping:
  - Cut fresh leaf discs (approx. 5 cm diameter).
  - Dip into solution for 10 seconds (use forceps).
  - Checkpoint: Ensure complete surface wetting without run-off accumulation at edges.
- Drying: Air dry on paper towels for 1-2 hours at room temperature (25°C).
- Exposure: Place 10 larvae per petri dish (lined with moist filter paper). Replicate 3-5 times.
- Assessment: Record mortality at 48h and 72h.
  - Validation Rule: If Control mortality > 10%, the entire assay is invalid and must be repeated (Abbott's correction cannot fix poor handling).

## Protocol Logic Visualization

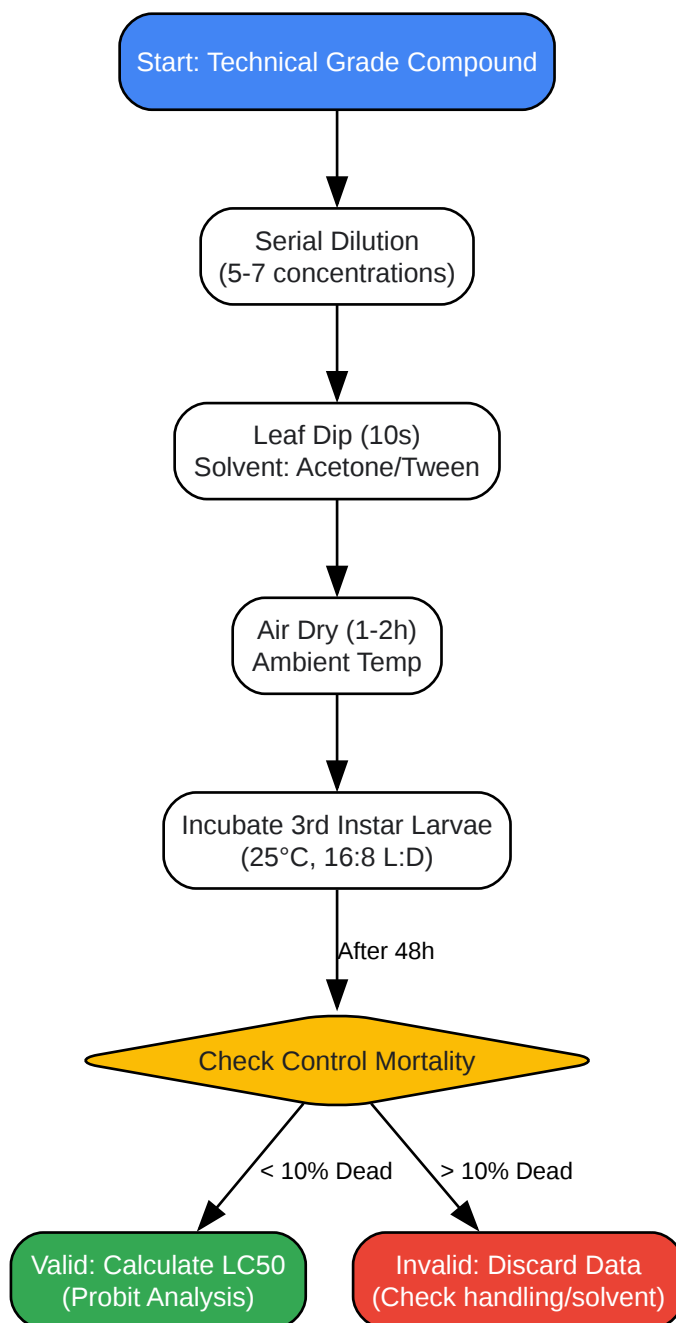

[Click to download full resolution via product page](#)

Caption: Figure 2. Decision logic for Leaf-Dip Bioassay validation.

## Comparative Efficacy Analysis

The following data synthesizes recent experimental findings comparing novel pyrazole derivatives (e.g., N-pyridylpyrazole thiazoles) against commercial standards.

## Efficacy Data Table (Target: *Plutella xylostella*)

Compound Class	Active Ingredient	LC50 (mg/L) [95% CI]	Relative Potency	Resistance Ratio (RR)*
Novel Pyrazole	Compound 7g (Experimental)	5.32 [3.95 - 7.18]	1.0x (Baseline)	N/A
Phenylpyrazole	Fipronil (Standard)	0.25 - 1.50	High	High in specific strains
Oxadiazine	Indoxacarb (Commercial Std)	5.01 [3.94 - 6.35]	1.06x	Low
Pyrethroid	Cypermethrin	> 150.0	Very Low	> 100 (Resistant)
Pyrazole-amide	Tolfenpyrad	~20.0	Moderate	Low (Cross-resistance rare)

### Key Insights:

- **Equipotency:** The novel pyrazole candidate (Compound 7g) demonstrates an LC50 (5.32 mg/L) statistically equivalent to the commercial standard Indoxacarb (5.01 mg/L).<sup>[5]</sup>
- **Resistance Breaking:** Pyrethroids like Cypermethrin show LC50 values >150 mg/L in resistant field strains due to kdr mutations. Pyrazoles remain effective in these populations because they target GABA receptors, not Na<sup>+</sup> channels.
- **Potency vs. Safety:** While Fipronil is the most potent (sub-ppm LC50), its high toxicity to non-targets (bees/fish) limits its utility compared to novel derivatives designed for higher selectivity.

## Structure-Activity Relationship (SAR) Note

Recent SAR studies indicate that introducing a thiazole moiety to the pyrazole ring (as seen in Compound 7g) enhances lipophilicity, improving cuticular penetration in Lepidoptera, while maintaining GABA receptor affinity.

## References

- Cole, L. M., et al. (1993). Action of phenylpyrazole insecticides at the GABA-gated chloride channel. *Pesticide Biochemistry and Physiology*. [Link](#)
- Zhao, X., et al. (2004). Fipronil modulation of glutamate-induced chloride currents in cockroach thoracic ganglion neurons. *NeuroToxicology*. [Link](#)
- Lv, M., et al. (2022). Discovery of Novel N-Pyridylpyrazole Thiazole Derivatives as Insecticide Leads. *Molecules (MDPI)*. [Link](#)
- World Health Organization (WHO). Tolfenpyrad: Pesticide Residues in Food 2013 Evaluations. [Link](#)
- Insecticide Resistance Action Committee (IRAC). Method No. 7: Leaf Dip Bioassay. [Link](#)

### Need Custom Synthesis?

BenchChem offers custom synthesis for rare earth carbides and specific isotopic labeling.

Email: [info@benchchem.com](mailto:info@benchchem.com) or [Request Quote Online](#).

## Sources

- 1. [semanticscholar.org](https://www.semanticscholar.org) [[semanticscholar.org](https://www.semanticscholar.org)]
- 2. Glutamate-activated chloride channels: Unique fipronil targets present in insects but not in mammals - PMC [[pmc.ncbi.nlm.nih.gov](https://pubmed.ncbi.nlm.nih.gov/)]
- 3. GABAA Receptor Subunit Composition Drives Its Sensitivity to the Insecticide Fipronil - PMC [[pmc.ncbi.nlm.nih.gov](https://pubmed.ncbi.nlm.nih.gov/)]
- 4. [Frontiers | GABAA Receptor Subunit Composition Drives Its Sensitivity to the Insecticide Fipronil](https://www.frontiersin.org) [[frontiersin.org](https://www.frontiersin.org)]
- 5. [mdpi.com](https://www.mdpi.com) [[mdpi.com](https://www.mdpi.com)]
- To cite this document: BenchChem. [Comparative Efficacy Guide: Pyrazole-Based Insecticides vs. Commercial Standards]. BenchChem, [2026]. [Online PDF]. Available at: [<https://www.benchchem.com/product/b1287666/docs#comparative-efficacy-guide-pyrazole-based-insecticides-vs-commercial-standards>]

**Disclaimer & Data Validity:**

The information provided in this document is for Research Use Only (RUO) and is strictly not intended for diagnostic or therapeutic procedures. While BenchChem strives to provide accurate protocols, we make no warranties, express or implied, regarding the fitness of this product for every specific experimental setup.

**Technical Support:** The protocols provided are for reference purposes. Unsure if this reagent suits your experiment?

**Need Industrial/Bulk Grade?** [Request Custom Synthesis Quote](#)

## BenchChem

Our mission is to be the trusted global source of essential and advanced chemicals, empowering scientists and researchers to drive progress in science and industry.

### Contact

Address: 3281 E Guasti Rd  
Ontario, CA 91761, United States  
Phone: (601) 213-4426  
Email: [info@benchchem.com](mailto:info@benchchem.com)

[Contact our Ph.D. Support Team for a compatibility check](#)