

Application Note: Experimental Setup for 4-Fluoropicolinic Acid Reactions

Author: BenchChem Technical Support Team. **Date:** May 2026

Compound of Interest

Compound Name: 4-Fluoropicolinic acid

CAS No.: 886371-78-4

Cat. No.: B1287997

[Get Quote](#)

Part 1: Molecule Profile & Strategic Overview

4-Fluoropicolinic acid (4-FPA) is a bifunctional pyridine building block.^{[1][2]} Unlike its isomer 2-fluoroisonicotinic acid, 4-FPA possesses a unique electronic push-pull system defined by the ortho-located carboxylic acid (the "Anchor") and the para-located fluorine (the "Handle") relative to the pyridine nitrogen.^[1]

Physicochemical Data Table

Property	Value	Notes
IUPAC Name	4-Fluoro-2-pyridinecarboxylic acid	
CAS Number	886371-78-4	Critical:[1][3] Do not confuse with 2-fluoro-4-pyridinecarboxylic acid (CAS 402-65-3).[1]
Molecular Weight	141.10 g/mol	
Acidity ()	-5.2 (Predicted)	Slightly more acidic than picolinic acid (5.4) due to F-inductive effect. [1]
Solubility	DMSO, DMF, MeOH	Poor solubility in non-polar solvents (, Hexanes).
Stability	Thermal Sensitivity	Risk of Decarboxylation at .

Reactivity Map (Graphviz)[1]

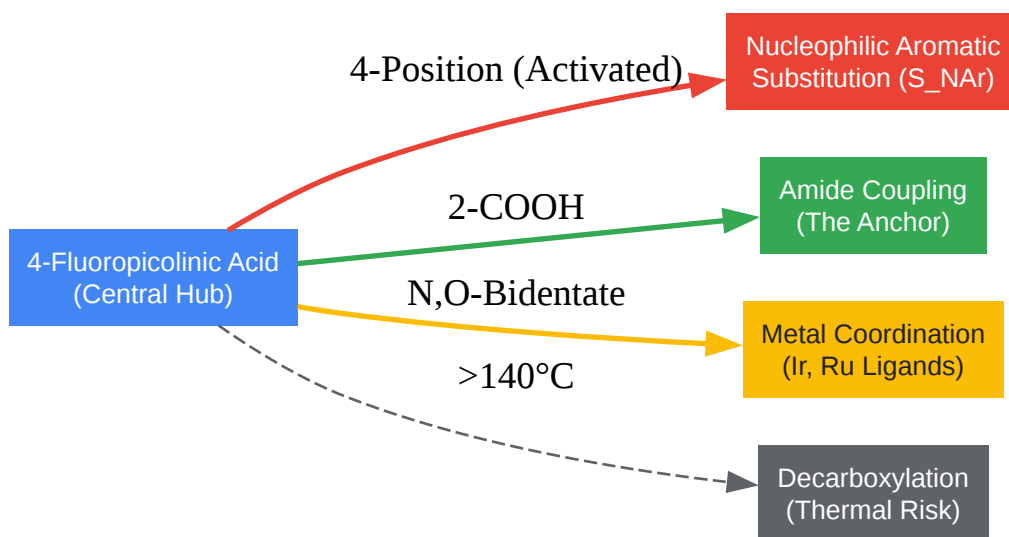

[Click to download full resolution via product page](#)

Caption: Reactivity landscape of **4-Fluoropicolinic acid**. The 4-fluoro position is highly activated for substitution, while the 2-COOH serves as a stable anchor for coupling or coordination.[1]

Part 2: Core Protocols

Protocol A: Site-Selective Functionalization

Objective: Displacement of the 4-Fluorine atom with amines or alkoxides.[1] Mechanism: The 4-position is activated by the pyridine nitrogen (para-effect) and the electron-withdrawing carboxyl group (meta-effect).[1] The nitrogen effect dominates, making this position highly electrophilic.

Reagents:

- Substrate: **4-Fluoropicolinic acid** (1.0 equiv)[1]
- Nucleophile: Primary/Secondary Amine (1.2 – 1.5 equiv)[1]
- Base:
(2.0 equiv) or DIPEA (3.0 equiv)[1]
- Solvent: DMSO (preferred) or DMF. Avoid protic solvents if using alkoxides.

Step-by-Step Methodology:

- Preparation: Dissolve 4-FPA in DMSO (0.2 M concentration).
- Addition: Add the base followed by the amine nucleophile.
 - Note: If the amine is a hydrochloride salt, increase base equivalents by 1.0.
- Reaction: Heat the mixture to 80–100°C for 4–12 hours.
 - Monitoring: Monitor by LCMS. The product will show a mass shift corresponding to

(loss of F).

- Checkpoint: If reaction is sluggish, increase temp to 120°C, but do not exceed 140°C to prevent decarboxylation.
- Workup (Acidic Precipitate):
 - Cool to room temperature.[4]
 - Dilute carefully with water (5x volume).
 - Adjust pH to ~3–4 using 1N HCl. The amino-picolinic acid product often precipitates as a zwitterion.
 - Filter and wash with cold water/ether.

Troubleshooting:

- Hydrolysis: If OH⁻ replaces F (formation of 4-hydroxypicolinic acid), ensure reagents are dry and reduce water content in the solvent.[1]

Protocol B: Amide Coupling (Linker Synthesis)

Objective: Coupling the 2-COOH to an amine without disturbing the 4-F handle.[1] Challenge: Picolinic acids can suffer from slow activation due to the proximity of the pyridine nitrogen (sterics/electronics) and potential N-oxide formation if using wrong oxidants.

Reagents:

- Coupling Agent: HATU (1.1 equiv) or T3P (50% in EtOAc, 1.5 equiv).
- Base: DIPEA (3.0 equiv).
- Solvent: DMF or DCM.

Step-by-Step Methodology:

- Activation: Dissolve 4-FPA (1.0 equiv) and DIPEA (3.0 equiv) in DMF. Stir for 5 mins.

- Reagent Addition: Add HATU (1.1 equiv). Stir for 15 mins to form the active ester (yellowing often observed).
- Coupling: Add the amine partner (1.0–1.1 equiv).
- Incubation: Stir at Room Temperature (RT) for 2–16 hours.
 - Note: Heating is rarely required and should be avoided to preserve the 4-F group for later stages.
- Workup:
 - Dilute with EtOAc. Wash with sat.^[5]
, water, and brine.
 - Caution: Do not use strong acid washes (1N HCl) if the product contains basic nitrogens, as it will extract into the aqueous layer.

Protocol C: Iridium(III) Complex Synthesis

Objective: Synthesis of Heteroleptic Ir(III) complexes for OLEDs using 4-FPA as an ancillary ligand. Context: Picolinates are excellent ancillary ligands that tune the emission spectrum (blue-shift relative to acac).^[1]

Workflow Diagram (Graphviz)

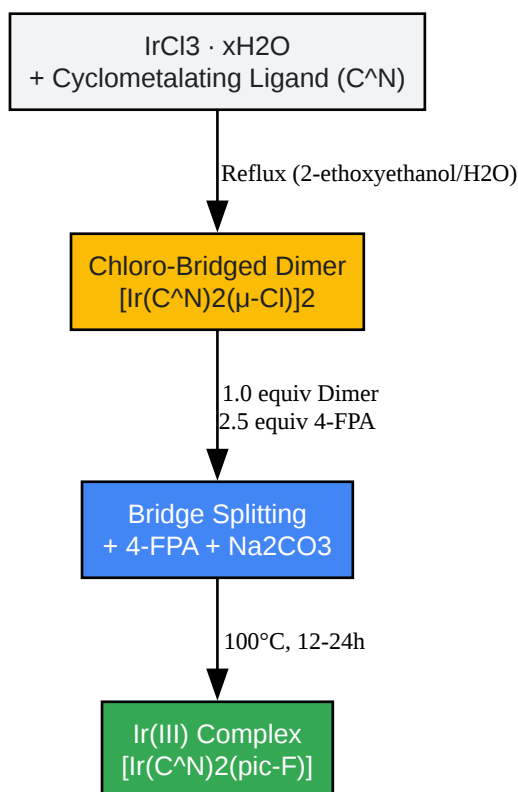

[Click to download full resolution via product page](#)

Caption: Standard "Nonoyama" route for synthesizing Iridium-Picolinate complexes.

Step-by-Step Methodology:

- Dimer Formation: React with the main ligand (e.g., ppy,) in 2-ethoxyethanol/water (3:1) at 110°C for 24h. Isolate the precipitate (Dimer).
- Bridge Splitting:
 - Suspend the Dimer (1.0 equiv) and **4-Fluoropicolinic acid** (2.5 equiv) in 2-ethoxyethanol.
 - Add (10 equiv) to deprotonate the acid and scavenge chloride.
- Complexation: Heat to 100°C under inert atmosphere (

) for 12–16 hours.

- Purification:
 - Cool to RT. The product often precipitates or can be precipitated by adding water.
 - Filter and wash with water/methanol.
 - Recrystallize from DCM/Hexanes or purify via silica column (DCM:MeOH gradient).

Part 3: Safety & Handling Guide

Decarboxylation Hazard

Picolinic acids are thermodynamically unstable relative to pyridine.

- Trigger: Temperatures
or strong acidic conditions at high heat.
- Prevention: Keep reaction temperatures below 120°C. If high-temp workup is needed (e.g., distillation), ensure the mixture is neutral or slightly basic.^[1]

Fluoride Release

While the C-F bond is stable, harsh nucleophilic conditions (e.g., using hydroxide or methoxide at high temp) can release fluoride ions (

).[1]

- Glassware: Standard borosilicate is generally safe unless using highly concentrated strong bases at reflux.
- Waste: Segregate waste streams if significant defluorination is suspected (rare in standard protocols).

Storage

- Store at 2–8°C (Refrigerated).

- Keep container tightly sealed; picolinic acids can be hygroscopic.

References

- Chemical Identity & Properties
 - Source: PubChem Compound Summary for CID 11378949 (Derivative ref) and commercial catalog data for CAS 886371-78-4.[1]
 - Link: (General reference for class properties).[1]
- Synthesis of 4-Fluoropicolinates
 - Source: Patent WO2019040102A1 (Therapeutic heterocyclic compounds).
 - Link:[1]
- Iridium Complex Synthesis (General Protocol)
 - Source: Synthesis and Characterization of Iridium(III) Complexes, PMC 107504. Describes the bridge-splitting mechanism with picolinic acids.[1]
 - Link:[1]
- Decarboxylation Kinetics
 - Source: Kinetics and mechanism of decarboxylation of some pyridinecarboxylic acids. Canadian Journal of Chemistry.
 - Link:[1]

Need Custom Synthesis?

BenchChem offers custom synthesis for rare earth carbides and specific isotopic labeling.

Email: info@benchchem.com or [Request Quote Online](#).

Sources

- [1. patentimages.storage.googleapis.com](https://patentimages.storage.googleapis.com) [patentimages.storage.googleapis.com]
- [2. lookchem.com](https://lookchem.com) [lookchem.com]
- [3. Product Category-AccelaChem|AccelaChemBio|Accela design, synthesis, manufacture and market advanced R&D chemicals;韶远科技（上海）有限公司](#) [accelachem.com]
- [4. 4-Fluorobenzoic acid | 456-22-4](https://chemicalbook.com) [chemicalbook.com]
- [5. researchgate.net](https://researchgate.net) [researchgate.net]
- To cite this document: BenchChem. [Application Note: Experimental Setup for 4-Fluoropicolinic Acid Reactions]. BenchChem, [2026]. [Online PDF]. Available at: [<https://www.benchchem.com/product/b1287997/docs#application-note-experimental-setup-for-4-fluoropicolinic-acid-reactions>]

Disclaimer & Data Validity:

The information provided in this document is for Research Use Only (RUO) and is strictly not intended for diagnostic or therapeutic procedures. While BenchChem strives to provide accurate protocols, we make no warranties, express or implied, regarding the fitness of this product for every specific experimental setup.

Technical Support: The protocols provided are for reference purposes. Unsure if this reagent suits your experiment?

Need Industrial/Bulk Grade? [Request Custom Synthesis Quote](#)

BenchChem

Our mission is to be the trusted global source of essential and advanced chemicals, empowering scientists and researchers to drive progress in science and industry.

Contact

Address: 3281 E Guasti Rd

Ontario, CA 91761, United States

Phone: (601) 213-4426

Email: info@benchchem.com

Contact our Ph.D. Support Team for a compatibility check