

# Application Note: Antifungal Development of Substituted Indole-3-Carbaldehydes

**Author:** BenchChem Technical Support Team. **Date:** April 2026

## Compound of Interest

**Compound Name:** 5-Bromo-7-methyl-1H-indole-3-carbaldehyde

**CAS No.:** 16076-86-1

**Cat. No.:** B1287213

[Get Quote](#)

## Executive Summary

The emergence of multidrug-resistant fungal pathogens (e.g., *Candida auris*, azole-resistant *Aspergillus fumigatus*) necessitates the development of novel antifungal pharmacophores.<sup>[1]</sup> Indole-3-carbaldehyde (I3A) derivatives represent a privileged scaffold due to their dual ability to disrupt fungal cell membranes and induce oxidative stress. This application note provides a comprehensive technical guide for the synthesis, biological evaluation, and mechanistic validation of substituted indole-3-carbaldehydes, specifically focusing on Schiff base and thiosemicarbazone derivatives.

## Chemical Background & Structure-Activity Relationships (SAR)

The indole moiety mimics the side chain of tryptophan, allowing these derivatives to intercalate into biological systems effectively. For antifungal applications, the C-3 formyl group serves as a versatile handle for functionalization.

## Key Structural Modifications

- Schiff Base Formation (Azomethines): Condensation of I3A with substituted anilines or hydrazides creates a linkage. This linker is critical for binding to fungal enzymes (e.g., CYP51).
  - SAR Insight: Electron-withdrawing groups (EWGs) like , , or on the phenyl ring of the Schiff base significantly enhance lipophilicity and antifungal potency [1].
- Thiosemicarbazones: Reaction with thiosemicarbazide yields ligands capable of chelating metal ions (Fe, Cu) essential for fungal metabolism.
  - SAR Insight: The sulfur atom acts as a soft donor, increasing affinity for metal cofactors in fungal metalloenzymes [2].
- Halogenation of the Indole Ring:
  - SAR Insight: Halogenation at C5 or C6 (e.g., 5-bromo, 6-chloro) increases the compound's acidity and ability to penetrate the fungal cell wall [3].

## Visualization: Synthesis & SAR Logic

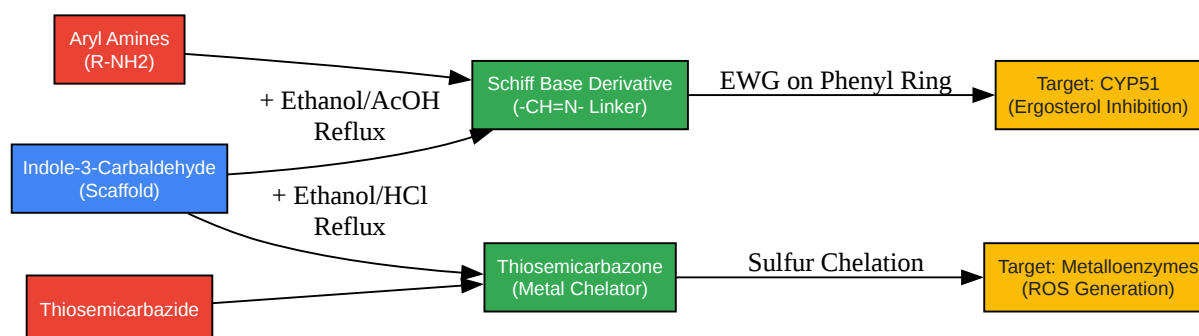

[Click to download full resolution via product page](#)

Figure 1: Synthetic pathways and resulting pharmacological targets for indole-3-carbaldehyde derivatives.

## Mechanism of Action (MOA)

Unlike conventional azoles that primarily target lanosterol 14

-demethylase, I3A derivatives often exhibit a multi-target mechanism, reducing the likelihood of resistance development.

- Ergosterol Biosynthesis Inhibition: The nitrogen lone pairs in the indole or Schiff base linkage coordinate with the heme iron of CYP51, blocking ergosterol synthesis and leading to membrane accumulation of toxic methylated sterols [4].
- ROS-Mediated Apoptosis: Certain derivatives, particularly halogenated ones, disrupt the mitochondrial electron transport chain (ETC). This leakage of electrons reacts with oxygen to form superoxide anions and hydroxyl radicals, triggering oxidative stress and DNA damage [5].
- Cell Wall Disruption: Interference with chitin synthase enzymes weakens the cell wall, leading to osmotic lysis.

## Visualization: Multi-Target Signaling

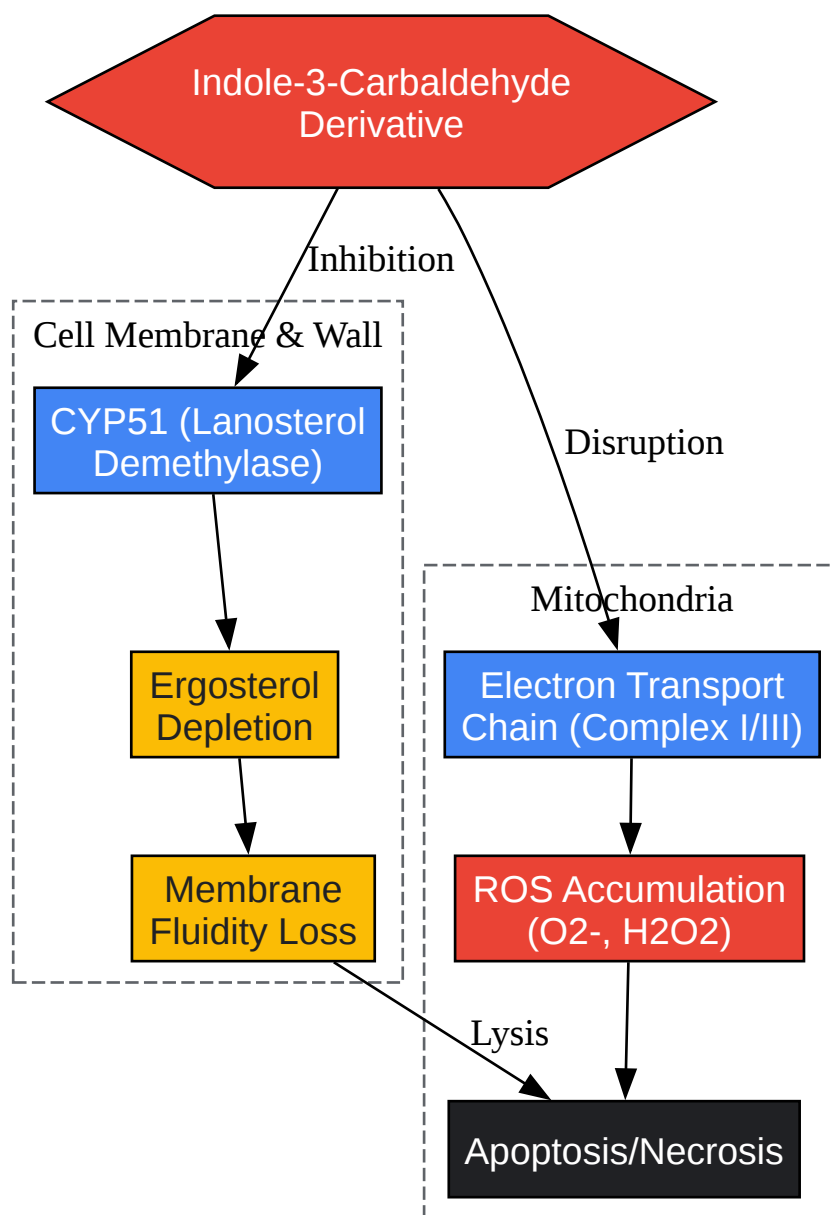

[Click to download full resolution via product page](#)

Figure 2: Dual-action mechanism involving ergosterol depletion and mitochondrial oxidative stress.

## Experimental Protocols

### Protocol A: Synthesis of Indole-3-Carbaldehyde Schiff Bases

Rationale: Acid-catalyzed condensation is the standard for generating the imine bond. Anhydrous conditions favor the equilibrium towards the product.

Materials:

- Indole-3-carbaldehyde (10 mmol)
- Substituted Aniline (e.g., 4-nitroaniline) (10 mmol)
- Absolute Ethanol (20 mL)
- Glacial Acetic Acid (3-4 drops)

Procedure:

- Dissolution: In a 50 mL round-bottom flask, dissolve 1.45 g (10 mmol) of indole-3-carbaldehyde in 20 mL of absolute ethanol.
- Addition: Add 10 mmol of the substituted aniline.
- Catalysis: Add 3-4 drops of glacial acetic acid.
- Reflux: Attach a reflux condenser and heat the mixture at 70-80°C for 4–6 hours. Monitor progress via TLC (Solvent system: Hexane:Ethyl Acetate 7:3).
- Precipitation: Pour the reaction mixture into 100 mL of ice-cold water. A solid precipitate should form immediately.
- Purification: Filter the solid under vacuum. Wash with cold water (3x) and cold ethanol (1x). Recrystallize from hot ethanol to yield pure crystals.
- Validation: Confirm structure via FTIR (look for stretch at  $\sim 1600\text{--}1620\text{ cm}^{-1}$ ) and  $^1\text{H}$  NMR (azomethine proton singlet at 8.0–9.0 ppm).

## Protocol B: Antifungal Susceptibility Testing (MIC)

Standard: CLSI M27-A3 (Yeasts) or M38-A2 (Filamentous Fungi).

Procedure:

- Inoculum Prep: Adjust *Candida albicans* or *Aspergillus niger* suspension to to CFU/mL (0.5 McFarland standard). Dilute 1:1000 in RPMI 1640 medium.
- Plate Setup: Use a 96-well microtiter plate. Dispense 100  $\mu$ L of RPMI 1640 into all wells.
- Compound Dilution: Add 100  $\mu$ L of the indole derivative (stock in DMSO) to column 1. Perform serial 2-fold dilutions across the plate. Final concentration range: 0.5 – 256  $\mu$ g/mL.
- Inoculation: Add 100  $\mu$ L of the diluted fungal inoculum to each well.
- Controls:
  - Positive Control: Fluconazole or Amphotericin B.
  - Growth Control: Media + Inoculum + DMSO (solvent).[2]
  - Sterility Control: Media only.
- Incubation: Incubate at 35°C for 24h (*Candida*) or 48h (*Aspergillus*).
- Readout: The MIC is the lowest concentration showing 100% inhibition of visible growth (optically clear).

## Protocol C: Mechanism Validation (Sorbitol Protection Assay)

Rationale: If the compound acts on the cell wall, sorbitol will act as an osmotic protectant, raising the MIC value compared to sorbitol-free media.

Procedure:

- Duplicate Setup: Prepare two sets of MIC plates (as in Protocol B).

- Set A: Standard RPMI 1640.
- Set B: RPMI 1640 supplemented with 0.8 M Sorbitol.
- Execution: Run the MIC assay simultaneously for the test compound and a control (e.g., Caspofungin - cell wall active).
- Analysis:
  - If MIC (Set A)  $\ll$  MIC (Set B) (e.g., 4-fold increase), the compound targets the cell wall.
  - If MIC (Set A) MIC (Set B), the mechanism is likely membrane or intracellular (e.g., ergosterol or DNA).

## Data Presentation & Analysis

### Representative Activity Data

The following table illustrates typical MIC ranges for optimized derivatives compared to standards.

Compound Class	R-Substituent	Organism	MIC ( $\mu\text{g/mL}$ )	Activity Level
Schiff Base	4-Nitro-phenyl	C. albicans	8 - 16	High
Schiff Base	4-Methoxy-phenyl	C. albicans	64 - 128	Low
Thiosemicarbazone	H (Unsubstituted)	A. niger	12 - 25	Moderate
Standard	Fluconazole	C. albicans	2 - 4	Reference

### Screening Workflow Diagram

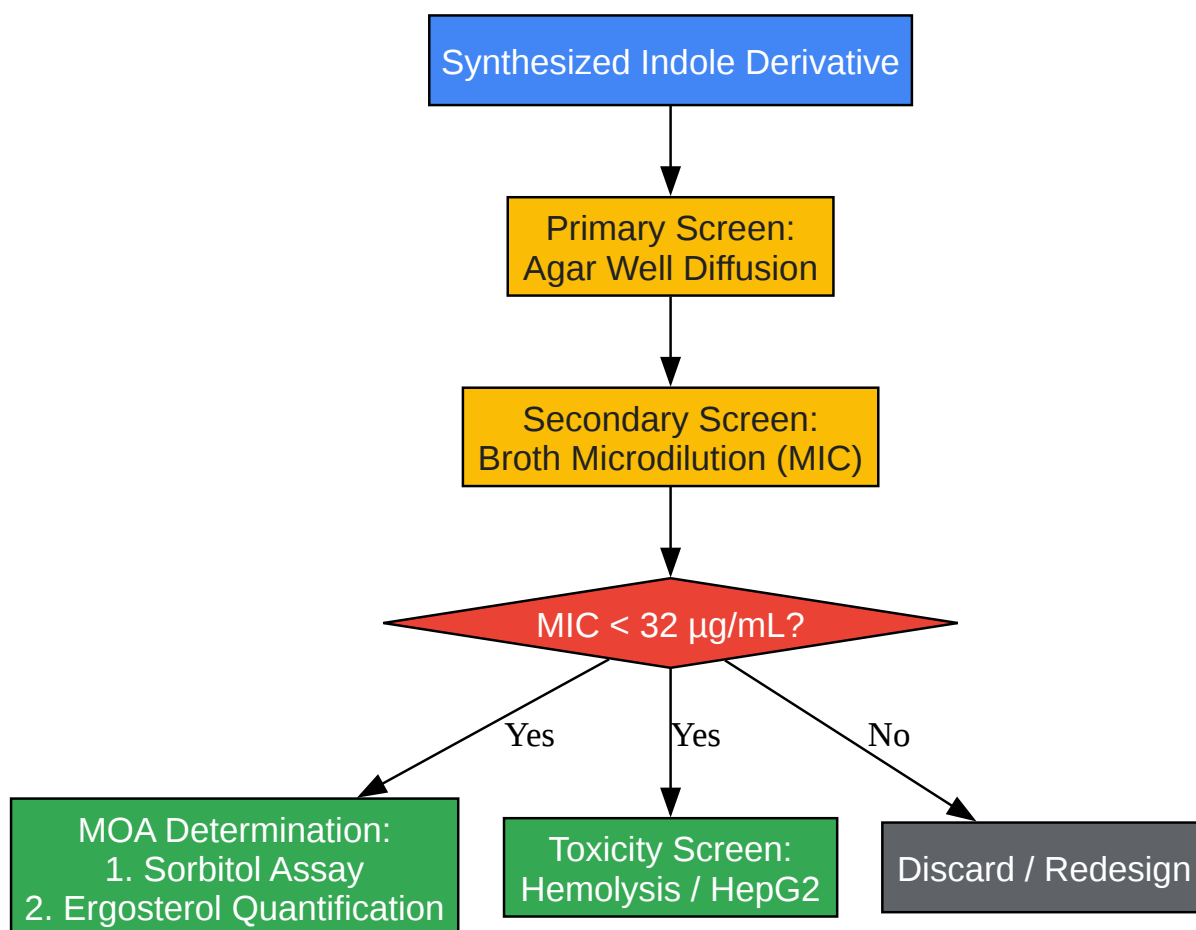

[Click to download full resolution via product page](#)

Figure 3: Decision tree for evaluating novel indole antifungal candidates.

## References

- Schiff Bases of Indole-3-Carbaldehyde: Synthesis and Evaluation as Antimicrobial Agents. *Journal of Advanced Chemical Sciences*. [3](#)[1][4][5][2][6][7][8][9][3][10]
- Synthesis, characterization and antiameobic activity of new indole-3-carboxaldehyde thiosemicarbazones and their Pd(II) complexes. *European Journal of Medicinal Chemistry*. [5](#)[1][7][9]
- Antifungal Activities of Multi-Halogenated Indoles Against Drug-Resistant *Candida* Species. *MDPI Pharmaceuticals*. [1](#)[1][5][7][9]

- Synthesis, structure-activity relationship and biological evaluation of indole derivatives as anti-Candida albicans agents. *Bioorganic Chemistry*.11[1][7][9]
- Effects and Inhibition Mechanism of Indole-3-Carboxaldehyde in Controlling Scutellaria baicalensis Root Rot. *MDPI Microorganisms*.9[1][7][9]

### Need Custom Synthesis?

BenchChem offers custom synthesis for rare earth carbides and specific isotopic labeling.

Email: [info@benchchem.com](mailto:info@benchchem.com) or [Request Quote Online](#).

## Sources

- 1. [mdpi.com](https://www.mdpi.com) [[mdpi.com](https://www.mdpi.com)]
- 2. [ajol.info](https://www.ajol.info) [[ajol.info](https://www.ajol.info)]
- 3. [researchgate.net](https://www.researchgate.net) [[researchgate.net](https://www.researchgate.net)]
- 4. [repositorio.ulima.edu.pe](https://repositorio.ulima.edu.pe) [[repositorio.ulima.edu.pe](https://repositorio.ulima.edu.pe)]
- 5. Synthesis, characterization and antiameobic activity of new indole-3-carboxaldehyde thiosemicarbazones and their Pd(II) complexes - PubMed [[pubmed.ncbi.nlm.nih.gov](https://pubmed.ncbi.nlm.nih.gov)]
- 6. [iipseries.org](https://www.iipseries.org) [[iipseries.org](https://www.iipseries.org)]
- 7. [researchgate.net](https://www.researchgate.net) [[researchgate.net](https://www.researchgate.net)]
- 8. [researchgate.net](https://www.researchgate.net) [[researchgate.net](https://www.researchgate.net)]
- 9. Effects and Inhibition Mechanism of Indole-3-Carboxaldehyde in Controlling Scutellaria baicalensis Root Rot | MDPI [[mdpi.com](https://www.mdpi.com)]
- 10. Indole-3-carbaldehyde - Wikipedia [[en.wikipedia.org](https://en.wikipedia.org)]
- 11. Synthesis, structure-activity relationship and biological evaluation of indole derivatives as anti-Candida albicans agents - PubMed [[pubmed.ncbi.nlm.nih.gov](https://pubmed.ncbi.nlm.nih.gov)]
- To cite this document: BenchChem. [Application Note: Antifungal Development of Substituted Indole-3-Carbaldehydes]. BenchChem, [2026]. [Online PDF]. Available at: [<https://www.benchchem.com/product/b1287213/docs#application-note-antifungal-development-of-substituted-indole-3-carbaldehydes>]

---

### Disclaimer & Data Validity:

The information provided in this document is for Research Use Only (RUO) and is strictly not intended for diagnostic or therapeutic procedures. While BenchChem strives to provide accurate protocols, we make no warranties, express or implied, regarding the fitness of this product for every specific experimental setup.

**Technical Support:** The protocols provided are for reference purposes. Unsure if this reagent suits your experiment?

**Need Industrial/Bulk Grade?** [Request Custom Synthesis Quote](#)

## BenchChem

Our mission is to be the trusted global source of essential and advanced chemicals, empowering scientists and researchers to drive progress in science and industry.

### Contact

Address: 3281 E Guasti Rd  
Ontario, CA 91761, United States  
Phone: (601) 213-4426  
Email: [info@benchchem.com](mailto:info@benchchem.com)

[Contact our Ph.D. Support Team for a compatibility check](#)