

Application Notes and Protocols: Strategic Protection of the Aniline Moiety

Author: BenchChem Technical Support Team. **Date:** April 2026

Compound of Interest

Compound Name: *2-Iodo-5-methyl-3-(trifluoromethyl)aniline*

Cat. No.: *B12852020*

[Get Quote](#)

Authored by: Gemini, Senior Application Scientist

Introduction

The aniline moiety is a cornerstone of many pharmaceuticals, agrochemicals, and functional materials. However, the inherent nucleophilicity and basicity of the amino group ($-NH_2$) can interfere with a wide range of synthetic transformations. Direct modification of other parts of an aniline-containing molecule is often challenging, as the amino group can react with electrophiles, act as a base, or be oxidized. To circumvent these issues, the temporary "masking" of the amino group with a protecting group is a critical and widely employed strategy in multi-step organic synthesis.[1]

This guide provides an in-depth overview of common protecting group strategies for the aniline moiety, focusing on the causality behind experimental choices and providing detailed, field-proven protocols. We will explore the chemistry of carbamate, amide, and sulfonamide-based protecting groups, offering insights into their installation, stability, and selective removal.

The Logic of Protection: Why and When to Mask an Aniline

The decision to protect an aniline is driven by the need to prevent unwanted side reactions.

Key scenarios demanding protection include:

- Reactions involving strong electrophiles: Acylations, alkylations, and sulfonations intended for other parts of the molecule can readily occur at the nitrogen atom of an unprotected aniline.
- Conditions employing strong bases: The slightly acidic N-H proton can be abstracted by strong bases, leading to undesired reactivity.
- Oxidative transformations: The electron-rich nature of the aniline ring and the amino group makes them susceptible to oxidation.
- Directed ortho-metalation: Protection can be used to direct lithiation to the position ortho to the protected amino group.

An ideal protecting group should be:

- Easily and selectively introduced in high yield.
- Stable to a wide range of reaction conditions.
- Selectively removable in high yield under mild conditions that do not affect other functional groups.^[1]

The concept of orthogonality is paramount in complex syntheses. Orthogonal protecting groups can be removed under distinct sets of conditions, allowing for the selective deprotection of one functional group while others remain intact.^{[1][2][3]} For example, an acid-labile Boc group and a hydrogenation-labile Cbz group are orthogonal.^[3]

Carbamate Protecting Groups: The Workhorses of Amine Protection

Carbamates are among the most popular choices for protecting amines due to their ease of installation, general stability, and versatile removal options.[3]

tert-Butoxycarbonyl (Boc) Group

The Boc group is a cornerstone of modern organic synthesis, prized for its stability to a wide range of non-acidic conditions and its straightforward removal with acid.[4][5]

Causality of Use: The bulky tert-butyl group sterically hinders the nitrogen lone pair, reducing its nucleophilicity. The carbamate structure delocalizes the lone pair, further attenuating its reactivity.[1] The Boc group is stable to bases, nucleophiles, and catalytic hydrogenation, making it an excellent choice for a variety of subsequent transformations.[4]

Protection & Deprotection Workflow

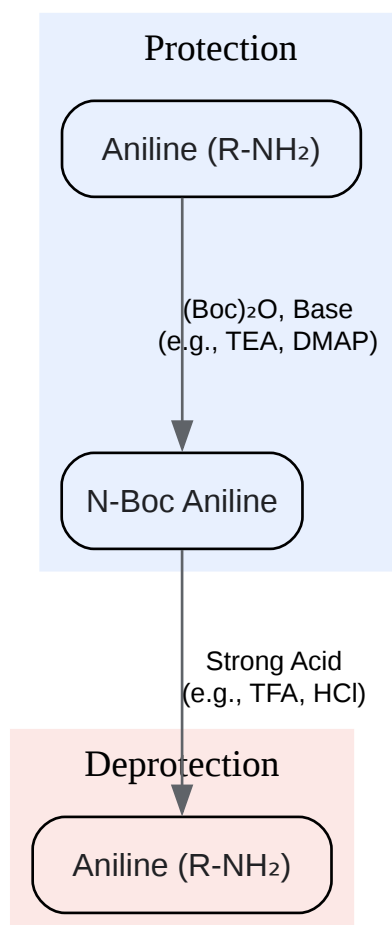

[Click to download full resolution via product page](#)

Caption: General workflow for Boc protection and deprotection of anilines.

Experimental Protocols

Protocol 1: N-Boc Protection of Aniline^{[6][7][8]}

- Materials: Aniline (1.0 eq.), Di-tert-butyl dicarbonate ((Boc)₂O, 1.1 eq.), Triethylamine (TEA, 1.5 eq.) or 4-(Dimethylamino)pyridine (DMAP, 0.1 eq.), Dichloromethane (DCM) or Tetrahydrofuran (THF).
- Procedure:
 - Dissolve the aniline in DCM in a round-bottom flask equipped with a magnetic stir bar.
 - Add TEA or DMAP to the solution.
 - Add (Boc)₂O to the mixture in one portion. For more reactive anilines, cooling the reaction to 0 °C is recommended to control the exotherm.
 - Stir the reaction mixture at room temperature. Monitor the reaction progress by Thin Layer Chromatography (TLC) until the starting aniline is consumed (typically 1-4 hours).
 - Upon completion, dilute the reaction mixture with DCM and wash with 1M HCl (to remove excess base), followed by saturated NaHCO₃ solution, and finally brine.
 - Dry the organic layer over anhydrous Na₂SO₄ or MgSO₄, filter, and concentrate under reduced pressure to yield the N-Boc protected aniline, which can often be used without further purification.

Protocol 2: N-Boc Deprotection using Trifluoroacetic Acid (TFA)^{[7][8]}

- Materials: N-Boc protected aniline, Trifluoroacetic acid (TFA), Dichloromethane (DCM).
- Procedure:
 - Dissolve the N-Boc protected aniline in DCM (a typical concentration is 0.1-0.5 M).

- Add an equal volume of TFA to the solution (e.g., 5 mL of DCM and 5 mL of TFA). The reaction is often accompanied by gas (isobutylene) evolution.
- Stir the mixture at room temperature. Monitor the deprotection by TLC (usually complete within 30-60 minutes).
- Once the reaction is complete, remove the solvent and excess TFA under reduced pressure.
- To obtain the free amine, dissolve the resulting TFA salt in DCM and wash with a saturated NaHCO_3 or NaOH solution until the aqueous layer is basic.
- Separate the organic layer, dry over anhydrous Na_2SO_4 , filter, and concentrate to yield the deprotected aniline.

Benzyloxycarbonyl (Cbz or Z) Group

The Cbz group is another widely used carbamate protecting group, notable for its stability to both acidic and basic conditions.^[9] Its key feature is its lability towards catalytic hydrogenation.^{[3][9]}

Causality of Use: The Cbz group is electronically similar to the Boc group in terms of deactivating the amine. Its primary advantage is its orthogonality to the Boc group. It is the protecting group of choice when acid-labile functionalities must be preserved in the molecule.^[8] The removal mechanism via hydrogenolysis is mild and clean, producing toluene and carbon dioxide as byproducts.^[9]

Protection & Deprotection Workflow

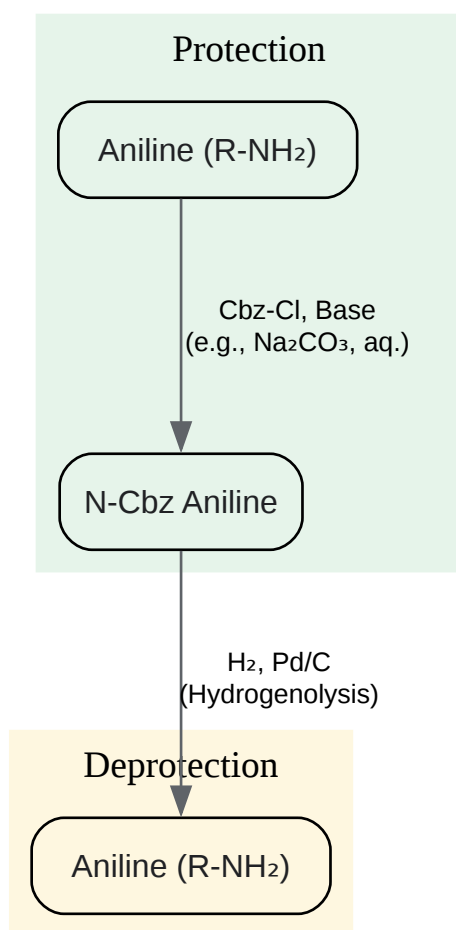

[Click to download full resolution via product page](#)

Caption: General workflow for Cbz protection and deprotection of anilines.

Experimental Protocols

Protocol 3: N-Cbz Protection of Aniline (Schotten-Baumann conditions)^{[9][10]}

- Materials: Aniline (1.0 eq.), Benzyl chloroformate (Cbz-Cl, 1.1 eq.), Sodium carbonate (Na_2CO_3 , 2.0 eq.), Dioxane or THF, Water.
- Procedure:
 - Dissolve the aniline in dioxane or THF in a flask.
 - In a separate flask, dissolve Na_2CO_3 in water.

- Cool the aniline solution to 0 °C in an ice bath.
- Add the Na₂CO₃ solution to the aniline solution with vigorous stirring.
- Add Cbz-Cl dropwise to the biphasic mixture.
- Allow the reaction to warm to room temperature and stir for 2-4 hours, monitoring by TLC.
- Extract the mixture with ethyl acetate or DCM.
- Wash the combined organic layers with water and brine.
- Dry the organic layer over anhydrous Na₂SO₄, filter, and concentrate under reduced pressure. Purify by column chromatography if necessary.

Protocol 4: N-Cbz Deprotection via Catalytic Hydrogenolysis[8][9]

- Materials: N-Cbz protected aniline, Palladium on carbon (Pd/C, 5-10 wt%), Methanol (MeOH) or Ethyl Acetate (EtOAc), Hydrogen (H₂) gas source (balloon or Parr shaker).
- Procedure:
 - Dissolve the N-Cbz protected aniline in MeOH or EtOAc in a flask suitable for hydrogenation.
 - Carefully add Pd/C to the solution under an inert atmosphere (e.g., nitrogen or argon). Caution: Pd/C can be pyrophoric.
 - Evacuate the flask and backfill with H₂ gas (repeat 3 times).
 - Stir the reaction mixture vigorously under a positive pressure of H₂ (a balloon is sufficient for most small-scale reactions) at room temperature.
 - Monitor the reaction by TLC. The reaction is typically complete within 2-16 hours.
 - Once complete, carefully filter the reaction mixture through a pad of Celite® to remove the Pd/C catalyst. Caution: Do not allow the Celite pad with the catalyst to dry completely, as it can ignite in air. Wash the pad with the reaction solvent.

- Concentrate the filtrate under reduced pressure to yield the deprotected aniline.

Amide Protecting Groups: The Acetyl (Ac) Group

The acetyl group is a simple, inexpensive, and robust protecting group. It is typically introduced by treating the aniline with acetic anhydride or acetyl chloride.^[11]

Causality of Use: Acetamide formation significantly reduces the basicity and nucleophilicity of the aniline nitrogen. Acetanilides are stable to a wide range of synthetic conditions, including many oxidative and reductive methods. However, their removal requires harsh conditions, typically strong acid or base hydrolysis, which can limit their applicability in the synthesis of complex molecules with sensitive functional groups.^{[11][12]}

Experimental Protocols

Protocol 5: Acetyl Protection of Aniline

- Materials: Aniline (1.0 eq.), Acetic anhydride (1.2 eq.), Pyridine (optional, as catalyst or solvent).
- Procedure:
 - Dissolve the aniline in a suitable solvent like DCM or use pyridine as the solvent.
 - Slowly add acetic anhydride to the solution at room temperature. The reaction is often exothermic.
 - Stir for 1-2 hours until TLC analysis indicates complete consumption of the aniline.
 - Pour the reaction mixture into water and extract with ethyl acetate.
 - Wash the organic layer sequentially with 1M HCl, saturated NaHCO₃, and brine.
 - Dry over anhydrous Na₂SO₄, filter, and concentrate to yield the acetanilide, which can often be purified by recrystallization.

Protocol 6: Hydrolysis (Deprotection) of Acetanilide^{[12][13][14]}

- Materials: Acetanilide, Concentrated Hydrochloric Acid (HCl) or Sodium Hydroxide (NaOH) solution.
- Procedure (Acidic Hydrolysis):
 - Suspend the acetanilide in 6M HCl.
 - Heat the mixture to reflux. The solid will gradually dissolve as the hydrolysis proceeds.
 - Monitor the reaction by TLC (typically several hours).
 - After completion, cool the reaction mixture to room temperature.
 - Neutralize the solution by the slow addition of a strong base (e.g., 10M NaOH) until the pH is >10.
 - Extract the liberated aniline with a suitable organic solvent (e.g., ethyl acetate).
 - Dry the organic extract and concentrate under reduced pressure to obtain the aniline.

Sulfonamide Protecting Groups: Robustness and Tunable Lability

Sulfonamides are among the most robust amine protecting groups, stable to a wide range of acidic and oxidative conditions.^{[15][16]} This stability, however, can make their removal challenging.^[17]

p-Toluenesulfonyl (Tosyl, Ts) Group

The tosyl group is a classic sulfonamide protecting group known for its high stability.^[17]

Causality of Use: The powerful electron-withdrawing nature of the sulfonyl group renders the nitrogen lone pair non-basic and non-nucleophilic.^[18] Tosylamides are exceptionally stable, withstanding strongly acidic and basic conditions, as well as many oxidizing and reducing agents. This robustness is also its main drawback, as cleavage often requires harsh conditions like sodium in liquid ammonia or strong acids at high temperatures.^{[17][18]}

Protocol 7: Tosylation of Aniline^[15]

- Materials: Aniline (1.0 eq.), p-Toluenesulfonyl chloride (TsCl, 1.1 eq.), Pyridine.
- Procedure:
 - Dissolve the aniline in pyridine at 0 °C.
 - Slowly add TsCl to the solution.
 - Allow the reaction to warm to room temperature and stir for 4-16 hours.
 - Pour the reaction mixture into ice-water and extract with ethyl acetate.
 - Wash the organic layer extensively with 1M HCl (to remove pyridine), followed by water and brine.
 - Dry over anhydrous Na₂SO₄, filter, and concentrate. Purify by recrystallization or column chromatography.

2-Nitrobenzenesulfonyl (Nosyl, Ns) and 4-Nitrobenzenesulfonyl Groups

The nosyl group was developed to address the difficult cleavage of the tosyl group.[\[17\]](#)

Causality of Use: The presence of the electron-withdrawing nitro group on the aromatic ring makes the sulfur atom of the sulfonamide highly electrophilic. This facilitates nucleophilic aromatic substitution at the carbon bearing the sulfonyl group, leading to cleavage of the S-N bond under mild conditions with soft nucleophiles like thiols.[\[19\]](#) This provides a much milder deprotection method compared to that required for tosylamides.

Protocol 8: Nosyl Deprotection[\[19\]](#)

- Materials: N-Nosyl protected aniline, Thiophenol (PhSH, 2-5 eq.), Potassium carbonate (K₂CO₃, 2-5 eq.), Acetonitrile (MeCN) or Dimethylformamide (DMF).
- Procedure:
 - Dissolve the N-nosyl aniline in MeCN or DMF.

- Add K_2CO_3 and thiophenol to the solution.
- Stir the mixture at room temperature or warm gently (e.g., 50 °C) for 1-5 hours, monitoring by TLC.
- Upon completion, dilute with water and extract with ethyl acetate.
- Wash the organic layer with saturated $NaHCO_3$ solution and brine.
- Dry over anhydrous Na_2SO_4 , filter, and concentrate. Purify by column chromatography to remove disulfide byproducts.

Comparative Summary of Protecting Groups

Protecting Group	Introduction Reagent	Common Deprotection Conditions	Stability Profile	Orthogonality & Notes
Boc	(Boc) ₂ O	Strong Acid (TFA, HCl)[4][8]	Stable to base, nucleophiles, hydrogenolysis. [4]	Orthogonal to Cbz, Fmoc, and Nosyl. Widely used due to mild removal.
Cbz (Z)	Cbz-Cl	H ₂ , Pd/C (Catalytic Hydrogenolysis) [8][9]	Stable to acid and base.[9]	Orthogonal to Boc and Fmoc. Sensitive to some reducing agents.
Acetyl (Ac)	Ac ₂ O, AcCl	Strong Acid or Base, Reflux[11] [12]	Very robust. Stable to mild acid/base, many redox conditions.	Limited orthogonality due to harsh removal. Often used to moderate reactivity for electrophilic aromatic substitution.
Tosyl (Ts)	TsCl	Very harsh: Na/liq. NH ₃ , HBr/reflux[17] [20]	Extremely stable to acid, base, oxidants, and reductants.[17]	Limited use in complex synthesis due to difficult removal.
Nosyl (Ns)	NsCl	Mild: Thiol (e.g., PhSH) + Base[19]	Stable to acid. Nitro group is sensitive to reduction.[15]	Orthogonal to Boc and Cbz. The go-to robust group when mild cleavage is required.

Conclusion

The strategic selection and application of protecting groups are fundamental to the successful execution of complex organic syntheses. For the aniline moiety, carbamates like Boc and Cbz offer a versatile and often orthogonal approach, providing a balance of stability and mild deprotection conditions. Amides serve as robust, inexpensive options when harsh deprotection is tolerable. Sulfonamides, particularly the nosyl group, provide exceptional stability with the option for mild, thiol-mediated cleavage. By understanding the underlying chemical principles and causality for the use of each protecting group, researchers can devise more efficient and effective synthetic routes for the development of novel molecules.

References

- Hydrolysis of Acetanilide: Mechanism & Explanation. Study.com. [[Link](#)][12][14]
- Deprotection of anilines under microwave-assisted conditions using TFE and HFIP as solvents. ResearchGate. [[Link](#)]
- What is the mechanism of Acetanilide?. Patsnap Synapse. [[Link](#)]
- Reactivity of acetanilides in the alkaline hydrolysis reaction: theory vs. experiment. Taylor & Francis Online. [[Link](#)][11]
- Hydrolysis of Acetanilide Study. Scribd. [[Link](#)][13]
- Two New Orthogonal Amine-Protecting Groups that can be Cleaved under Mild or Neutral Conditions. Journal of the American Chemical Society. [[Link](#)][2]
- Boc-Protected Amino Groups. Organic Chemistry Portal. [[Link](#)][4]
- Protective Groups. Organic Chemistry Portal. [[Link](#)][1]
- Protecting Groups for Amines: Carbamates. Master Organic Chemistry. [[Link](#)][3]
- Molecular Iodine-Catalyzed Facile Procedure for N-Boc Protection of Amines. The Journal of Organic Chemistry. [[Link](#)]

- A New Selective Cleavage of N,N-Dicarbamoyl-Protected Amines Using Lithium Bromide. Scilit. [\[Link\]](#)
- orthogonal oligonucleotide protecting group strategy that enables assembly of repetitive or highly structured DNAs. Nucleic Acids Research. [\[Link\]](#)
- Cbz Protecting Group: N-Cbz Protection & Deprotection Mechanism. Total Synthesis. [\[Link\]](#) [\[9\]](#)
- Nms-Amides: An Amine Protecting Group with Unique Stability and Selectivity. Angewandte Chemie. [\[Link\]](#)[\[17\]](#)
- Selective Thermal Deprotection of N-Boc Protected Amines in Continuous Flow. Organic Letters. [\[Link\]](#)
- Chemoselective Radical Cleavage of Cbz-Protected Nitrogen Compounds. ResearchGate. [\[Link\]](#)
- Selective Cleavage of Cbz-Protected Amines. ResearchGate. [\[Link\]](#)
- MULTISTEP SYNTHESIS PROTECTING GROUPS. University of Massachusetts. [\[Link\]](#)
- Organic Syntheses Procedure. Organic Syntheses. [\[Link\]](#)[\[16\]](#)
- A Brønsted Acidic Deep Eutectic Solvent for N-Boc Deprotection. MDPI. [\[Link\]](#)
- Rapid and Selective Cleavage of Amide Groups at Neutral pH: Applications from Hyaluronic Acid to Small Molecules. ResearchGate. [\[Link\]](#)
- Comparison of various catalysts in the N-Boc protection of aniline with (Boc) 2 O at room temperature. ResearchGate. [\[Link\]](#)
- Selective Cleavage of N -Benzyl-Protected Secondary Amines by Triphosgene. Scilit. [\[Link\]](#)
- Removal of the tosyl and nosyl groups. ResearchGate. [\[Link\]](#)
- Backbone Protecting Groups for Enhanced Peptide and Protein Synthesis. National Institutes of Health. [\[Link\]](#)

- 26.04 Protecting Groups for Amines: Sulfonamides. YouTube. [[Link](#)][18]
- Amine synthesis by carbamate cleavage. Organic Chemistry Portal. [[Link](#)]
- Selected examples showing the chemoselective cleavage of the acetamide groups over other Boc, other amides and esters. ResearchGate. [[Link](#)]
- Adding Cbz Protecting Group Mechanism. YouTube. [[Link](#)][10]
- Highly efficient chemoselective N-TBS protection of anilines under exceptional mild conditions in the eco-friendly solvent 2-methyltetrahydrofuran. Royal Society of Chemistry. [[Link](#)]
- Deprotective Functionalization: An Emerging Concept for Amine Reactivity. ChemSusChem. [[Link](#)]
- A simple and mild method for the removal of the Nlm-tosyl protecting group. SciSpace. [[Link](#)]
- Boc Protecting Group for Amines. Chemistry Steps. [[Link](#)][5]
- Cbz-Protected Amino Groups. Organic Chemistry Portal. [[Link](#)]
- Mechanistic Insight into Cleavable 4-Aminopyrazolyloxy Acetamide at Low pH. PubMed. [[Link](#)]
- Selected examples looking at the chemoselective cleavage of acetamides in the presence of commonly-used amine protecting groups. ResearchGate. [[Link](#)]
- Amine Protection and Deprotection. Master Organic Chemistry. [[Link](#)]
- Fukuyama Amine Synthesis. Chem-Station. [[Link](#)][19]
- Tosyl group. Wikipedia. [[Link](#)]
- Does anyone know of a method to remove a nosyl group that's been reduced to the amine?. Reddit. [[Link](#)][20]

Need Custom Synthesis?

BenchChem offers custom synthesis for rare earth carbides and specific isotopic labeling.

Email: info@benchchem.com or [Request Quote Online](#).

Sources

- [1. Protective Groups \[organic-chemistry.org\]](#)
- [2. pubs.acs.org \[pubs.acs.org\]](#)
- [3. masterorganicchemistry.com \[masterorganicchemistry.com\]](#)
- [4. Boc-Protected Amino Groups \[organic-chemistry.org\]](#)
- [5. Boc Protecting Group for Amines - Chemistry Steps \[chemistrysteps.com\]](#)
- [6. sigmaaldrich.com \[sigmaaldrich.com\]](#)
- [7. pdf.benchchem.com \[pdf.benchchem.com\]](#)
- [8. pdf.benchchem.com \[pdf.benchchem.com\]](#)
- [9. total-synthesis.com \[total-synthesis.com\]](#)
- [10. youtube.com \[youtube.com\]](#)
- [11. tandfonline.com \[tandfonline.com\]](#)
- [12. study.com \[study.com\]](#)
- [13. scribd.com \[scribd.com\]](#)
- [14. Hydrolysis of Acetanilide: Mechanism & Explanation - Video | Study.com \[study.com\]](#)
- [15. benchchem.com \[benchchem.com\]](#)
- [16. Organic Syntheses Procedure \[orgsyn.org\]](#)
- [17. Nms-Amides: An Amine Protecting Group with Unique Stability and Selectivity - PMC \[pmc.ncbi.nlm.nih.gov\]](#)
- [18. youtube.com \[youtube.com\]](#)
- [19. Fukuyama Amine Synthesis | Chem-Station Int. Ed. \[en.chem-station.com\]](#)
- [20. reddit.com \[reddit.com\]](#)
- To cite this document: BenchChem. [Application Notes and Protocols: Strategic Protection of the Aniline Moiety]. BenchChem, [2026]. [Online PDF]. Available at:

[\[https://www.benchchem.com/product/b12852020/docs#application-notes-and-protocols-strategic-protection-of-the-aniline-moiety\]](https://www.benchchem.com/product/b12852020/docs#application-notes-and-protocols-strategic-protection-of-the-aniline-moiety)

Disclaimer & Data Validity:

The information provided in this document is for Research Use Only (RUO) and is strictly not intended for diagnostic or therapeutic procedures. While BenchChem strives to provide accurate protocols, we make no warranties, express or implied, regarding the fitness of this product for every specific experimental setup.

Technical Support: The protocols provided are for reference purposes. Unsure if this reagent suits your experiment?

Need Industrial/Bulk Grade? [Request Custom Synthesis Quote](#)

BenchChem

Our mission is to be the trusted global source of essential and advanced chemicals, empowering scientists and researchers to drive progress in science and industry.

Contact

Address: 3281 E Guasti Rd
Ontario, CA 91761, United States
Phone: (601) 213-4426
Email: info@benchchem.com

[Contact our Ph.D. Support Team for a compatibility check](#)