

Comparative Guide: Mass Spectrometry Fragmentation of Azetidine Amino Acids

Author: BenchChem Technical Support Team. **Date:** April 2026

Compound of Interest

Compound Name: *2-Methylazetidine-2-carboxylic acid*
Cat. No.: *B12851096*

[Get Quote](#)

Executive Summary

Azetidine-2-carboxylic acid (Aze) is a toxic, non-proteinogenic homolog of proline containing a four-membered ring.^[1] Its structural similarity allows it to evade cellular proofreading and misincorporate into proteins (e.g., collagen, myelin), leading to proteotoxic stress.

For drug development and proteomics, distinguishing Aze from Proline is critical but challenging due to their similar physicochemical properties. This guide details the specific MS/MS fragmentation signatures—driven by ring strain and alpha-cleavage kinetics—that allow for the unambiguous identification of Aze residues in peptide sequences.

Key Differentiators at a Glance

Feature	Proline (Pro)	Azetidine-2-carboxylic acid (Aze)	Azetidine-3-carboxylic acid
Ring Size	5-membered (Pyrrolidine)	4-membered (Azetidine)	4-membered (Azetidine)
Residue Mass	97.05 Da	83.04 Da	83.04 Da
Diagnostic Immonium Ion	m/z 70	m/z 56	Weak/Absent (No -stabilization)
Fragmentation Behavior	"Proline Effect" (N-terminal cleavage)	"Proline Effect" (N-terminal cleavage)	Non-selective / Complex
Ring Strain Energy	~6 kcal/mol	~26 kcal/mol	~26 kcal/mol

Mechanistic Deep Dive: The "Azetidine Effect"

The fragmentation of Aze-containing peptides is governed by two competing forces: the high basicity of the secondary amine (similar to proline) and the immense ring strain of the four-membered system.

The Modified "Proline Effect"

In Collision-Induced Dissociation (CID), proline residues facilitate the cleavage of the peptide bond N-terminal to them. This occurs because the cyclic secondary amine is highly basic, sequestering the ionizing proton. The protonated nitrogen then facilitates a nucleophilic attack on the preceding carbonyl carbon, leading to the formation of a stable oxazolone b-ion and a truncated y-ion.

Aze-2-carboxylic acid exhibits this same behavior. Despite the ring strain, the secondary amine remains the preferred site of protonation.

- Observation: High intensity of the y-ion series starting at the Aze residue.
- Mechanism: Proton bridging between the amide nitrogen and the N-terminal carbonyl is energetically favorable, mirroring the "Proline Effect."

The Diagnostic Immonium Ion (m/z 56)

The most definitive spectral marker for Aze is its immonium ion.

- Proline: Forms a stable immonium ion at m/z 70 ().
- Azetidine-2-carboxylic acid: Forms a stable immonium ion at m/z 56 ().

This 14 Da mass shift is diagnostic. The formation of the m/z 56 ion proceeds via the loss of CO (28 Da) from the internal acylium ion (type fragment).

Ring Opening and Strain Release

Unlike Proline, the Aze ring is highly strained (~26 kcal/mol). Under higher collision energies (HCD or high-energy CID), the Aze ring is susceptible to ring-opening fragmentation.

- Pathway: Homolytic cleavage of the C-N bond or C-C bond within the ring.
- Result: While the intact immonium ion (m/z 56) is dominant at low energies, "satellite" ions corresponding to ring fragmentation (e.g., loss of) may appear at higher energies, though these are less reliable for quantification than the m/z 56 peak.

Comparative Analysis: Isomers and Homologs

Differentiation between the alpha-amino acid (Aze-2) and the beta-amino acid (Aze-3) is crucial for synthetic peptide validation.

Aze-2 vs. Aze-3 (Positional Isomers)

Azetidine-3-carboxylic acid is a

-amino acid analog. The carboxylic acid is attached to C3, not the

-carbon (C2) adjacent to the nitrogen.

- Aze-2 (Alpha): The proximity of the amine and carbonyl groups facilitates the formation of the 5-membered oxazolone intermediate required for standard backbone fragmentation. This yields clear b- and y-series ions.

- Aze-3 (Beta): The

-position disrupts the standard oxazolone formation pathway. Fragmentation is often dominated by non-sequence-specific pathways or retro-Mannich reactions. The m/z 56 immonium ion is significantly suppressed or absent because the

-cleavage mechanism cannot produce the resonance-stabilized species as efficiently.

Aze vs. Pipecolic Acid (Pip)

Pipecolic acid is the 6-membered ring homolog.

- Pip Effect: Unlike Pro and Aze, Pip residues often direct cleavage to the C-terminal amide bond (forming b-ions) due to steric factors preventing the N-terminal nucleophilic attack.
- Differentiation: Aze follows the Pro-like N-terminal cleavage; Pip follows C-terminal cleavage.

Visualization of Fragmentation Pathways[3][4][5][6]

The following diagram illustrates the divergent pathways for Proline and Azetidine-2-carboxylic acid, highlighting the critical mass shifts.

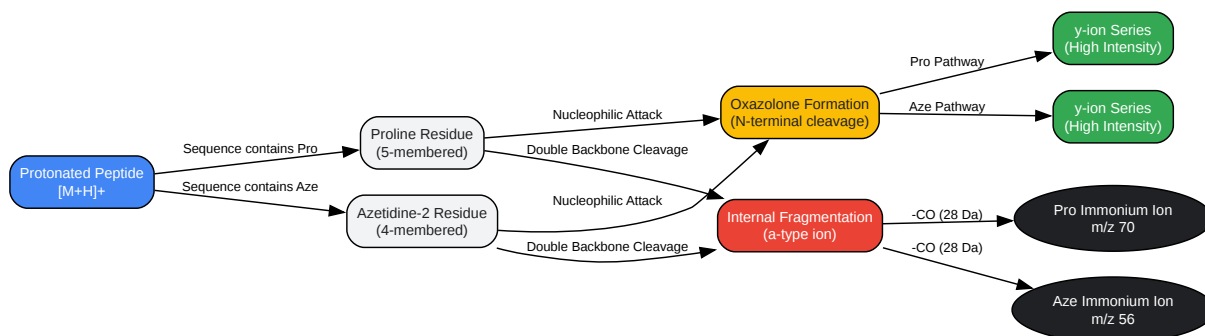

[Click to download full resolution via product page](#)

Caption: Comparative fragmentation pathways showing the parallel mechanisms of Pro and Aze, diverging only at the final mass of the diagnostic immonium ion.

Experimental Protocols

To reliably detect and differentiate Aze residues, the following protocol is recommended. This workflow is self-validating by using the m/z 56 ion as an internal check for the residue assignment.

Sample Preparation

- Derivatization (Optional): While Aze can be analyzed directly, derivatization with Fmoc or molecular weight tagging can improve retention on C18 columns, as free Aze is highly polar and elutes in the void volume.
- Digestion: For protein analysis, use Trypsin. Note that Trypsin may cleave C-terminal to Aze (similar to Pro) but with significantly reduced efficiency (approx. 10-100x slower), often resulting in missed cleavages.

LC-MS/MS Acquisition Parameters

- Ionization: Electrospray Ionization (ESI) in Positive Mode.

- Collision Energy (CE):
 - Screening: Use Stepped NCE (Normalized Collision Energy) of 25, 30, 35. High energy is required to efficiently generate the immonium ion from the strained ring.
 - Targeted: If performing PRM (Parallel Reaction Monitoring), set a specific inclusion for the m/z 56.05 fragment.
- Resolution: High resolution (Orbitrap/TOF) is recommended to distinguish the m/z 56.0500 () from the ubiquitous background (m/z 55.93) or (m/z 56.06).

Data Analysis Workflow

- Search Parameter: Define Aze as a variable modification on Proline (-14.0156 Da) or as a custom amino acid "Aze" (Mass: 83.0371 Da).
- Filter 1 (Retention Time): Aze-containing peptides typically elute slightly earlier than their Pro-containing counterparts on Reverse Phase (C18) due to the smaller hydrophobic surface area of the 4-membered ring.
- Filter 2 (Diagnostic Ion): Extract the ion chromatogram (XIC) for m/z 56.0500.
 - Validation Logic: If the peptide spectrum contains the -14 Da shift vs Pro sequence BUT lacks the m/z 56 ion (at high CE), suspect the Azetidine-3-carboxylic acid isomer or a linear isomer.

Summary of Diagnostic Data

Parameter	Value / Observation	Notes
Monoisotopic Mass (Residue)	83.0371 Da	Used for precursor mass calculation.
Mass Difference vs Pro	-14.0156 Da	"Lighter Proline"
Immonium Ion	m/z 56.0500	Primary Diagnostic. High specificity.
y-ion Series	Enhanced N-terminal cleavage	Similar to Proline; intense y-ions at Aze.
Trypsin Cleavage	Inhibited / Slow	Expect missed cleavages at ...-Aze-K-... sites.
Elution Order (RP-HPLC)	Aze < Pro	Aze is slightly more polar/compact.

References

- Rodgers, K. J., et al. (2024). A comprehensive review of the proline mimic azetidine-2-carboxylic acid (A2C). Toxicology. [Link](#)
- Matrix Science. (n.d.). Peptide Fragmentation and Immonium Ions. Mascot Help. [Link](#)
- Rubenstein, E., et al. (2009).[2] Azetidine-2-carboxylic acid in the food chain. Phytochemistry. [Link](#)
- Zagol-Ikapitte, I., et al. (2019). Characterization of Azetidine-2-carboxylic Acid Containing Peptides by Tandem Mass Spectrometry.
- NIST Chemistry WebBook. (2025). 2-Azetidinecarboxylic acid Mass Spectrum. [Link](#)

Need Custom Synthesis?

BenchChem offers custom synthesis for rare earth carbides and specific isotopic labeling.

Email: info@benchchem.com or [Request Quote Online](#).

Sources

- [1. Azetidine-2-carboxylic acid - Wikipedia \[en.wikipedia.org\]](#)
- [2. medchemexpress.com \[medchemexpress.com\]](#)
- To cite this document: BenchChem. [Comparative Guide: Mass Spectrometry Fragmentation of Azetidine Amino Acids]. BenchChem, [2026]. [Online PDF]. Available at: [\[https://www.benchchem.com/product/b12851096/docs#comparative-guide-mass-spectrometry-fragmentation-of-azetidine-amino-acids\]](https://www.benchchem.com/product/b12851096/docs#comparative-guide-mass-spectrometry-fragmentation-of-azetidine-amino-acids)

Disclaimer & Data Validity:

The information provided in this document is for Research Use Only (RUO) and is strictly not intended for diagnostic or therapeutic procedures. While BenchChem strives to provide accurate protocols, we make no warranties, express or implied, regarding the fitness of this product for every specific experimental setup.

Technical Support: The protocols provided are for reference purposes. Unsure if this reagent suits your experiment?

Need Industrial/Bulk Grade? [Request Custom Synthesis Quote](#)

BenchChem

Our mission is to be the trusted global source of essential and advanced chemicals, empowering scientists and researchers to drive progress in science and industry.

Contact

Address: 3281 E Guasti Rd
Ontario, CA 91761, United States
Phone: (601) 213-4426
Email: info@benchchem.com

[Contact our Ph.D. Support Team for a compatibility check](#)

