

## Analytical Comparison Guide: Mass Spectrometry Fragmentation Patterns of Phenethyl Carbamates (CID vs. HCD)

Author: BenchChem Technical Support Team. Date: April 2026

### Compound of Interest

Compound Name: 2-Phenylethyl carbonochloridate  
 CAS No.: 57913-41-4  
 Cat. No.: B1285426

[Get Quote](#)

Phenethyl carbamates represent a highly significant structural motif in medicinal chemistry, frequently appearing in neuroactive therapeutics, enzyme fentanyl derivatives)[1]. For drug development professionals and analytical chemists, accurate structural elucidation of these compounds relies on tar

This guide objectively compares the fragmentation dynamics of phenethyl carbamates using traditional Collision-Induced Dissociation (CID) and High understanding the causality behind these fragmentation pathways, researchers can optimize their analytical workflows to prevent misidentification of c

### Mechanistic Principles of Phenethyl Carbamate Fragmentation

Under positive electrospray ionization (ESI+), phenethyl carbamates typically protonate at the carbamate carbonyl oxygen or the nitrogen atom[2]. The relative bond dissociation energies, dictates the fragmentation cascade.

Two primary dissociation pathways dominate the MS/MS spectra of phenethyl carbamates:

- Carbamate Core Cleavage (Low Energy): Protonation at the carbonyl oxygen triggers the rearrangement and subsequent neutral loss of the esterif dioxide (-44 Da). For N-substituted carbamates, a characteristic neutral loss of an isocyanate (e.g., -57 Da) is frequently observed[2].
- Phenethyl Moiety Cleavage (High Energy): Cleavage of the alkyl-aryl bond or the C-N bond yields the highly stable phenethyl cation ( m/z 105) or a analogs, larger intermediate fragments (e.g., m/z 188) often undergo secondary dissociation to yield the m/z 105 diagnostic ion[1].

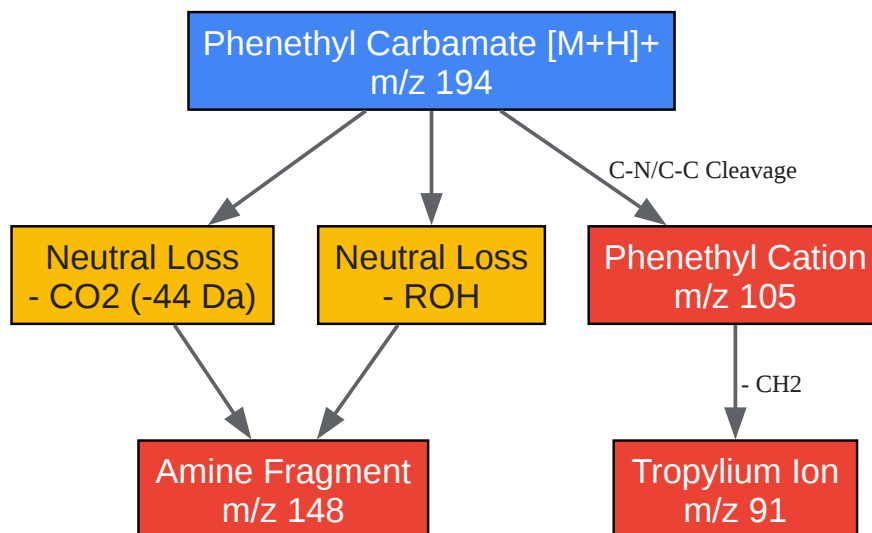

[Click to download full resolution via product page](#)

Primary MS/MS fragmentation pathways of a generic phenethyl carbamate.

## Technique Comparison: CID vs. HCD

The choice of activation method fundamentally dictates the depth of structural information acquired. Relying on a single fragmentation technique can

### Resonant-Excitation CID (Linear Ion Trap)

Traditional CID operates by trapping ions and heating them slowly through multiple low-energy collisions with an inert gas (e.g., Helium)[3].

- Causality of Spectra: Because the energy is deposited gradually, the molecule has time to distribute the energy vibrationally, causing only the weak H<sub>2</sub>O). Once fragmented, the product ions fall out of resonance and are not further excited[3].
- The "1/3 Rule" Limitation: Ion traps suffer from a low-mass cut-off dictated by the Mathieu stability parameter ( $q_z$ ). Ions with an  $m/z$  less than approximately one-third of the precursor will be trapped[4]. Consequently, for a precursor of  $m/z$  350, the critical phenethyl diagnostic ion at  $m/z$  105 will be entirely invisible.

### Beam-Type HCD (Multipole Collision Cell)

Higher-energy Collisional Dissociation (HCD) is a non-resonant, beam-type CID performed in a dedicated collision cell, typically coupled with an Orbitrap

- Causality of Spectra: Ions are accelerated to higher kinetic energies and undergo rapid, non-equilibrium fragmentation[3]. This shatters the molecule into secondary fragments (e.g., breaking down intermediate amine fragments directly into the  $m/z$  105 phenethyl cation)[1].
- No Mass Cut-off: HCD lacks the 1/3 rule limitation, allowing simultaneous observation of the intact precursor, intermediate fragments, and low-mass

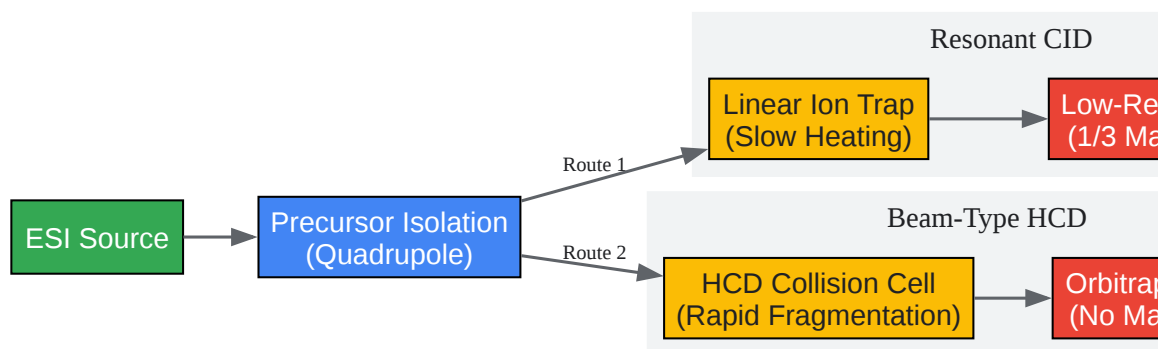

[Click to download full resolution via product page](#)

Instrumental workflow comparing Ion Trap CID and Orbitrap HCD activation.

## Quantitative Data Presentation

To illustrate the performance disparity, the table below summarizes the relative fragment abundances of a model compound (Ethyl N-phenethylcarbamate) at a Normalized Collision Energy (NCE) of 30%.

Fragment Ion	$m/z$	Structural Assignment	CID Relative Abundance (%)
[M+H-EtOH] <sup>+</sup>	148.1	Loss of Ethanol	100 (Base Peak)
[M+H-CO <sub>2</sub> -EtOH] <sup>+</sup>	104.1	Phenethylamine fragment	15
[C <sub>8</sub> H <sub>9</sub> ] <sup>+</sup>	105.1	Phenethyl cation	Not Detected (Cut-off)
[C <sub>7</sub> H <sub>7</sub> ] <sup>+</sup>	91.1	Tropylium ion	Not Detected (Cut-off)

Analytical Insight: Relying solely on CID risks missing the m/z 105 and 91 peaks, which are the most definitive structural markers of the phenethyl group fingerprint where both the intact carbamate core (via neutral losses) and the peripheral phenethyl moiety are simultaneously confirmed.

## Self-Validating Experimental Protocol

To ensure rigorous and reproducible structural elucidation, implement the following parallel LC-MS/MS methodology using a tribrid mass spectrometer CID to confirm intact neutral losses and HCD to map the deep structural backbone.

### Step 1: Sample Preparation

- Dilute the phenethyl carbamate analyte to 100 ng/mL in a 50:50 mixture of Methanol:Water containing 0.1% Formic Acid to ensure optimal protonation.

### Step 2: Chromatographic Separation

- Column: Reverse-phase C18 (e.g., 2.1 x 50 mm, 1.7  $\mu$ m particle size)[2].
- Mobile Phases: (A) 0.1% Formic Acid in Water; (B) 0.1% Formic Acid in Acetonitrile.
- Gradient: 5% B to 95% B over 5 minutes at a flow rate of 0.4 mL/min. Inject 5  $\mu$ L.

### Step 3: Source Optimization

- Operate the ESI source in positive ion mode.
- Set the capillary voltage to 3.5 kV, sheath gas to 40 arb, and desolvation temperature to 350°C.

### Step 4: Parallel MS/MS Acquisition (Data-Dependent Analysis)

- Survey Scan (MS1): Acquire in the Orbitrap at 120,000 resolution (m/z 100–800).
- CID Event: Isolate the precursor in the quadrupole (1.5 Da window). Route to the linear ion trap. Apply an NCE of 30%. Detect fragments in the ion neutral losses.
- HCD Event: Isolate the same precursor. Route to the HCD multipole cell. Apply a stepped NCE (e.g., 20%, 35%, 50%) to ensure both intermediate back to the Orbitrap for high-resolution, accurate-mass (HRAM) detection[5].

## References

- Quantification and Confirmation of Fifteen Carbamate Pesticide Residues by Multiple Reaction Monitoring and Enhanced Product Ion Scan Modes [https://vertexaisearch.cloud.google.com/grounding-api-redirect/AUZIYQGg12cTkW56JmSmqKdHxNiAk86iFshMzsg9RPk1tI0uppASQVwgyHQGKrMLzTvj4y9\_DIDcXeo7vYMG7h9SE0DQTo\_CZufiDrMsC]
- Analysis of Fentanyl and Fentanyl Analogs Using Atmospheric Pressure Chemical Ionization Gas Chromatography–Mass Spectrometry (APCI-GC-MS) [https://vertexaisearch.cloud.google.com/grounding-api-redirect/AUZIYQGgSkQg2ZqdBDtHPx\_aiCrweYY49aifNt-zjRnaQB\_3UE5VhdrSpJ0sbmm6zzLape9zsZL6dsW9T4zuD4mCgxKet2QSGyKJTv3\_dzpbncayYd6WuDY1CNHUGSy51tpytm9fxG]
- Difference between HCD and CID collision induced dissociations? Stack Exchange. [https://vertexaisearch.cloud.google.com/grounding-api-redirect/XO3R5Sq4pg\_aVW67TGNWLSveLIId6UBjVb5EcX1FODXEMRgjVrkc-TUIIdktXAJ20c55sOw4Zgw1Kn-kKvBtpziiwtk9xPHOX6xqwo3zXOgl\_d3WuLkTKinqTfsKvNwbN5S5EwKCSjzhDQ7NOzUPQj5WK2cWRt83D6OQn4pUzUwfkUwfmD4DBo06-HnYm8EB7-uLE=]
- Evaluation of HCD- and CID-type Fragmentation Within Their Respective Detection Platforms For Murine Phosphoproteomics. NIH. [https://vertexaisearch.cloud.google.com/grounding-api-redirect/AUZIYQEEaN8KFbJfIUeh50ZvRO5dCn\_ZuoKAAiheyIGs\_RsYj\_VC-oPMfLF8xtqTY9XCUI1WRqdmcawn4RbFmKvJpz3A0\_p11XRUYU8zKkcMkhXWSoiB3xyq\_TI\_Z3gS\_fg3\_VX0yUexcKE6\_GrBHg2a8=]
- Collision-induced dissociation. Wikipedia. [https://vertexaisearch.cloud.google.com/grounding-api-redirect/AUZIYQGE08TyAH-HYnolzN8KXsNq0etPKjYxFJybsXA8DXYSg\_76Gacy7e5iEJFJUDbktfdKgc1v1KcemqfV92r\_JMhfO2cl8ildAY7NTyBmYEZPDcqyY7GXt-lAdL9AbjbnAufA=]

### Need Custom Synthesis?

BenchChem offers custom synthesis for rare earth carbides and specific isotopic labeling.

Email: [info@benchchem.com](mailto:info@benchchem.com) or [Request Quote Online](#).

## Sources

- 1. Analysis of Fentanyl and Fentanyl Analogs Using Atmospheric Pressure Chemical Ionization Gas Chromatography–Mass Spectrometry (APCI-G
- 2. Quantification and Confirmation of Fifteen Carbamate Pesticide Residues by Multiple Reaction Monitoring and Enhanced Product Ion Scan Mod
- 3. [chemistry.stackexchange.com](https://chemistry.stackexchange.com) [[chemistry.stackexchange.com](https://chemistry.stackexchange.com)]
- 4. Collision-induced dissociation - Wikipedia [[en.wikipedia.org](https://en.wikipedia.org)]
- 5. Evaluation of HCD- and CID-type Fragmentation Within Their Respective Detection Platforms For Murine Phosphoproteomics - PMC [[pmc.ncbi.nlm.nih.gov/](https://pubmed.ncbi.nlm.nih.gov/)]
- To cite this document: BenchChem. [Analytical Comparison Guide: Mass Spectrometry Fragmentation Patterns of Phenethyl Carbamates (CID vs. Available at: [<https://www.benchchem.com/product/b1285426/docs#analytical-comparison-guide-mass-spectrometry-fragmentation-patterns-of-phe>]

---

### Disclaimer & Data Validity:

The information provided in this document is for Research Use Only (RUO) and is strictly not intended for diagnostic or therapeutic procedures. While protocols, we make no warranties, express or implied, regarding the fitness of this product for every specific experimental setup.

**Technical Support:** The protocols provided are for reference purposes. Unsure if this reagent suits your experiment?

**Need Industrial/Bulk Grade?** [Request Custom Synthesis Quote](#)

## BenchChem

Our mission is to be the trusted global source of essential and advanced chemicals, empowering scientists and researchers to drive progress in science and industry.

### Contact

Address: 3281 E Guasti Rd

Ontario, CA 91761, United States

Phone: (601) 213-4426

Email: [info@benchchem.com](mailto:info@benchchem.com)

---

[Contact our Ph.D. Support Team for a compatibility check](#)

---