

Technical Support Center: Enhancing Cellular Uptake of 2'-F-ANA-Based Therapeutics

Author: BenchChem Technical Support Team. **Date:** April 2026

Compound of Interest

Compound Name: 2'-Deoxy-2'-fluoroarabino inosine

Cat. No.: B12846601

[Get Quote](#)

Welcome to the technical support center for 2'-deoxy-2'-fluoro-arabinonucleic acid (2'-F-ANA) based therapeutics. This resource is designed for researchers, scientists, and drug development professionals to provide troubleshooting guidance and frequently asked questions (FAQs) to optimize your experiments and overcome common challenges in enhancing the cellular uptake and efficacy of 2'-F-ANA oligonucleotides.

Troubleshooting Guide

This guide addresses specific issues you may encounter during your experiments with 2'-F-ANA therapeutics.

Issue 1: Low Gene Silencing Efficacy

Possible Cause	Troubleshooting Steps
Poor Cellular Uptake	<ol style="list-style-type: none"> 1. Optimize Delivery Method: If using naked 2'-F-ANA (gymnotic delivery), ensure cells are amenable to this method. Consider alternative delivery strategies such as lipid-based transfection reagents, electroporation, or formulation into nanoparticles (e.g., Lipid Nanoparticles or Spherical Nucleic Acids).^{[1][2]} 2. Conjugation: Consider conjugating the 2'-F-ANA oligonucleotide to a ligand that targets a cell surface receptor to enhance receptor-mediated endocytosis. Fatty acid conjugation has been shown to enhance the potency of gymnotic delivery.^{[3][4]} 3. Increase Concentration: Titrate the concentration of the 2'-F-ANA oligonucleotide to determine the optimal dose for your cell type.
Nuclease Degradation	<ol style="list-style-type: none"> 1. Incorporate Phosphorothioate (PS) Linkages: While 2'-F-ANA modification itself increases nuclease resistance, incorporating PS linkages can further enhance stability.^{[5][6]} 2. Assess Serum Stability: If working in the presence of serum, evaluate the stability of your oligonucleotide over time.
Suboptimal Oligonucleotide Design	<ol style="list-style-type: none"> 1. Review "Gapmer" or "Altimer" Design: Ensure the design of your chimeric oligonucleotide (if applicable) is optimized for RNase H activity. A central DNA "gap" flanked by 2'-F-ANA wings is a common and effective design.^{[6][7][8]} 2. Target Site Selection: The accessibility of the target mRNA sequence can significantly impact efficacy. Use bioinformatics tools to select an optimal target site.
Inefficient Endosomal Escape	<ol style="list-style-type: none"> 1. Use Endosome-disrupting Agents: Some delivery reagents are designed to facilitate

endosomal escape. 2. Nanoparticle Formulation: Lipid nanoparticles can be engineered to promote endosomal release of their payload.^{[9][10]}

Issue 2: High Cellular Toxicity or Off-Target Effects

Possible Cause	Troubleshooting Steps
High Oligonucleotide Concentration	<ol style="list-style-type: none"> 1. Perform a Dose-Response Curve: Determine the lowest effective concentration that achieves the desired gene silencing while minimizing toxicity. 2. Reduce Transfection Reagent Amount: If using a delivery vehicle, optimize the ratio of the reagent to the oligonucleotide, as the delivery agent itself can be a source of toxicity.
"Off-Target" Hybridization	<ol style="list-style-type: none"> 1. Sequence Specificity Check: Perform a BLAST search of your oligonucleotide sequence against the relevant transcriptome to identify potential off-target binding sites. 2. Use Mismatch Controls: Include control oligonucleotides with mismatched sequences to demonstrate the sequence-specificity of the observed effect.
Immune Stimulation	<ol style="list-style-type: none"> 1. Chemical Modifications: 2'-F-ANA modifications have been shown to decrease immune side-effects.^[1] Ensure your oligonucleotide design incorporates sufficient modifications. 2. Purification: Ensure the oligonucleotide preparation is free of contaminants that could trigger an immune response.

Frequently Asked Questions (FAQs)

Q1: What are the main advantages of using 2'-F-ANA modifications in therapeutic oligonucleotides?

A1: 2'-F-ANA modifications offer several key advantages:

- **Increased Nuclease Resistance:** The 2'-fluoro group enhances stability against degradation by nucleases compared to unmodified DNA or RNA.[\[1\]](#)[\[3\]](#)
- **High Binding Affinity:** 2'-F-ANA oligonucleotides exhibit strong binding to complementary RNA targets.[\[11\]](#)[\[12\]](#)
- **RNase H Activation:** Unlike many other 2' modifications, 2'-F-ANA/RNA duplexes can effectively recruit and activate RNase H, leading to the degradation of the target mRNA.[\[6\]](#)[\[7\]](#)
[\[12\]](#)
- **Reduced Immunostimulatory Effects:** The modification can lead to decreased immune side-effects and toxicity.[\[1\]](#)

Q2: What is "gymnosis" and is it an effective delivery method for 2'-F-ANA?

A2: Gymnosis refers to the cellular uptake of naked antisense oligonucleotides without the use of any transfection reagents or carriers.[\[1\]](#)[\[3\]](#) 2'-F-ANA phosphorothioate gapmer oligonucleotides have been shown to be effective at silencing gene expression via gymnotic delivery in multiple cell lines.[\[3\]](#)[\[13\]](#) The efficiency of gymnosis can be cell-type dependent.

Q3: How can I quantify the cellular uptake of my 2'-F-ANA therapeutic?

A3: Several methods can be used to quantify cellular uptake:

- **Fluorescent Labeling:** Conjugate a fluorescent dye (e.g., Cy3, FITC) to the 2'-F-ANA oligonucleotide and measure intracellular fluorescence using flow cytometry or fluorescence microscopy.
- **Radiolabeling:** Radiolabel the oligonucleotide and quantify uptake by scintillation counting.
- **Quantitative PCR (qPCR):** After cell lysis and nucleic acid extraction, a qPCR-based method can be used to quantify the amount of internalized oligonucleotide.

- Slot Blot Analysis: This method can be used to quantify the amount of oligonucleotide present in cell lysates.[8][14]

Q4: What are the key differences between "gapmer" and "altimer" designs for 2'-F-ANA oligonucleotides?

A4:

- Gapmer: This design consists of a central block of deoxynucleotides (the "gap") that is flanked on both ends ("wings") by 2'-F-ANA modified nucleotides. This design is optimized for RNase H-mediated degradation of the target RNA, as the DNA gap is a substrate for RNase H.[8]
- Altimer: This design features alternating 2'-F-ANA and DNA modifications throughout the oligonucleotide sequence. This structure has also been shown to be highly potent in activating RNase H.[6]

Data Presentation

Table 1: Comparison of Gene Silencing Efficacy of PS-DNA vs. PS-2'-F-ANA-DNA Chimeras

Data synthesized from studies targeting c-MYB in human leukemia cells.

Oligonucleotide Type	Dose	c-MYB mRNA Knockdown (%)	Duration of Silencing
PS-DNA	5 µg	>90%	Effect diminishes significantly after 24h
PS-2'-F-ANA-DNA Chimera	5 µg	>90%	Effect persists for at least 96h
PS-2'-F-ANA-DNA Chimera	1 µg	~80-90%	-
PS-DNA	1 µg	No significant effect	-

(Source: Synthesized from data presented in references[7][8][14][15])

Table 2: Impact of 2'-F-ANA Modification on siRNA Serum Stability and Potency

siRNA Modification	Half-life in Serum	Potency (vs. unmodified)
Unmodified siRNA	<15 minutes	1x
Fully modified 2'-F-ANA sense strand / RNA antisense strand	~6 hours	4x more potent

(Source: Synthesized from data presented in references[5][16])

Experimental Protocols

Protocol 1: Lipid Nanoparticle (LNP) Formulation for 2'-F-ANA Delivery

This protocol provides a general framework for formulating 2'-F-ANA oligonucleotides into LNPs using a microfluidic mixing method.

Materials:

- Ionizable lipid (e.g., adamantane-based lipidoids)
- Helper lipid (e.g., DOPE)
- Cholesterol
- PEG-lipid (e.g., DMG-PEG2000)
- 2'-F-ANA oligonucleotide in an appropriate buffer (e.g., citrate buffer, pH 4.0)
- Ethanol
- PBS, pH 7.4
- Microfluidic mixing device

Procedure:

- Prepare the lipid mixture by dissolving the ionizable lipid, helper lipid, cholesterol, and PEG-lipid in ethanol at the desired molar ratio.
- Dissolve the 2'-F-ANA oligonucleotide in the aqueous buffer.
- Set up the microfluidic mixing device according to the manufacturer's instructions.
- Load the lipid-ethanol solution into one syringe and the oligonucleotide-aqueous solution into another.
- Pump the two solutions through the microfluidic device at a defined flow rate ratio (e.g., 3:1 aqueous to ethanol).
- The rapid mixing will induce the self-assembly of LNPs encapsulating the 2'-F-ANA.
- Dialyze the resulting LNP suspension against PBS (pH 7.4) to remove ethanol and non-encapsulated oligonucleotide.
- Characterize the LNPs for size, polydispersity, and encapsulation efficiency.
- The formulated LNPs are ready for in vitro or in vivo experiments.

(Source: Based on general principles of LNP formulation described in references[9][10][17])

Protocol 2: Electroporation (Nucleofection) of 2'-F-ANA Oligonucleotides

This protocol outlines a general procedure for delivering 2'-F-ANA oligonucleotides into mammalian cells using electroporation.

Materials:

- Mammalian cell line of interest
- Complete culture medium
- 2'-F-ANA oligonucleotide
- Electroporation system (e.g., Nucleofector™) and corresponding cuvettes

- Cell-type specific electroporation buffer/solution
- PBS

Procedure:

- Culture cells to the optimal confluency and ensure they are in the logarithmic growth phase.
- Harvest the required number of cells (e.g., 1×10^6 cells) by trypsinization or scraping, followed by centrifugation.
- Wash the cells once with PBS.
- Resuspend the cell pellet in the appropriate volume of cell-type specific electroporation solution.
- Add the desired amount of 2'-F-ANA oligonucleotide to the cell suspension and mix gently.
- Transfer the cell-oligonucleotide mixture to an electroporation cuvette.
- Place the cuvette in the electroporator and apply the pre-optimized electrical pulse program for your cell line.
- Immediately after electroporation, add pre-warmed complete culture medium to the cuvette and gently transfer the cells to a culture plate.
- Incubate the cells under standard conditions (e.g., 37°C, 5% CO₂).
- Analyze the cells for gene silencing or other downstream effects at the desired time points (e.g., 24, 48, 72 hours).

(Source: Based on general principles of electroporation described in references[7][8][14][18])

Visualizations

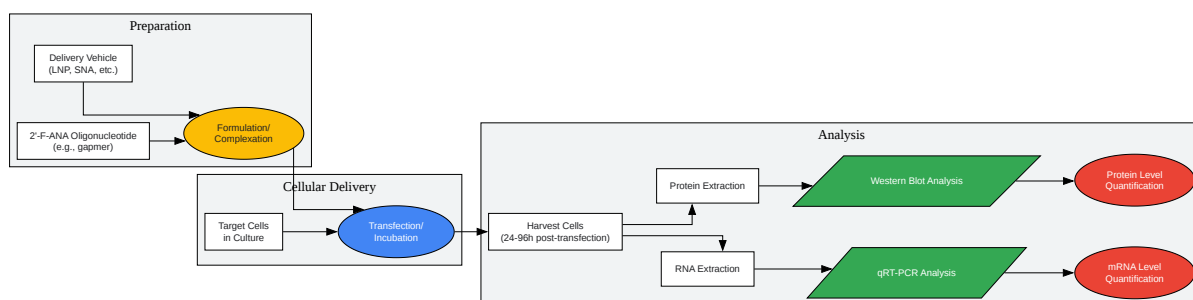

[Click to download full resolution via product page](#)

Caption: Experimental workflow for evaluating 2'-F-ANA gene silencing.

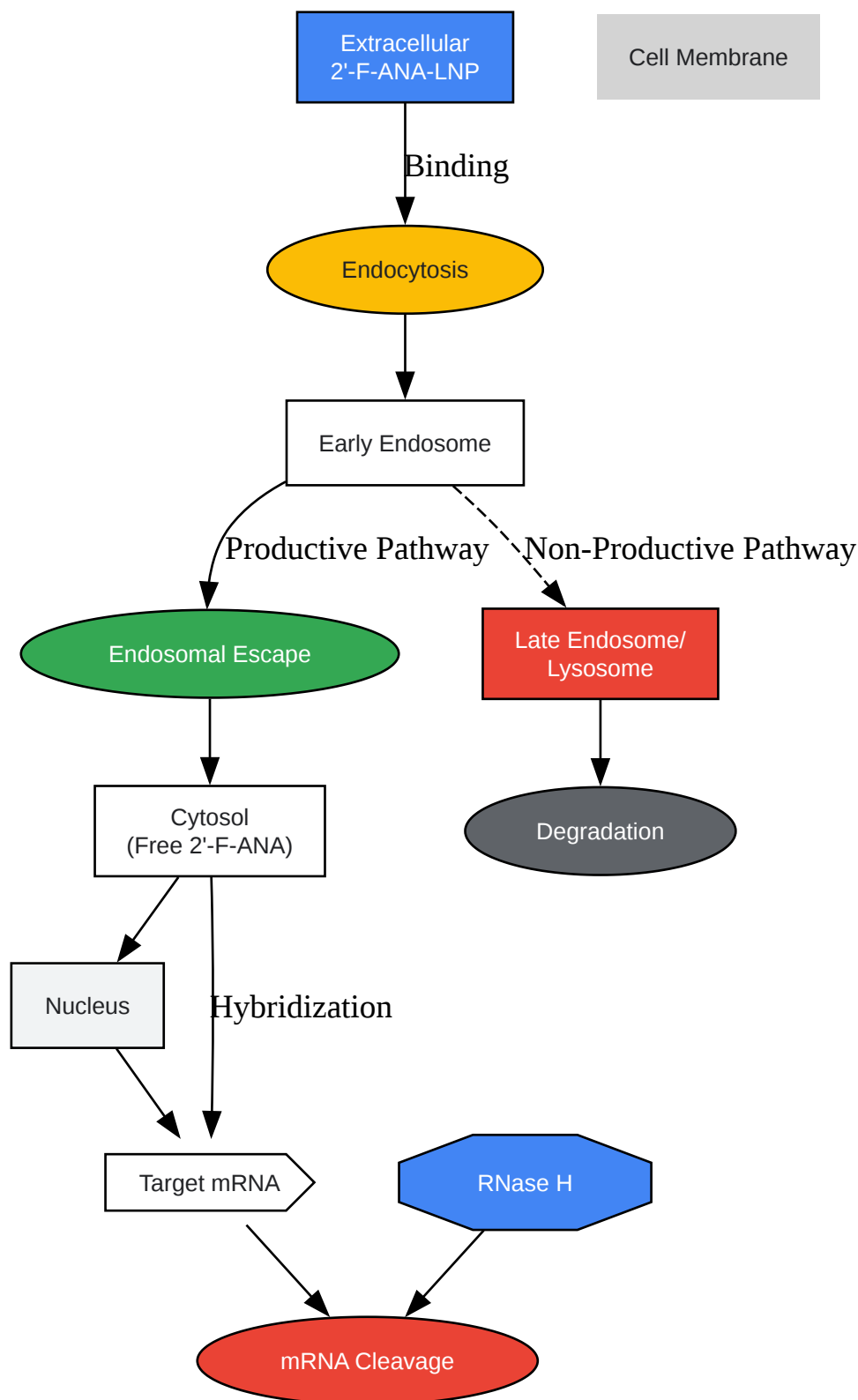

[Click to download full resolution via product page](#)

Caption: Cellular uptake and mechanism of action for 2'-F-ANA.

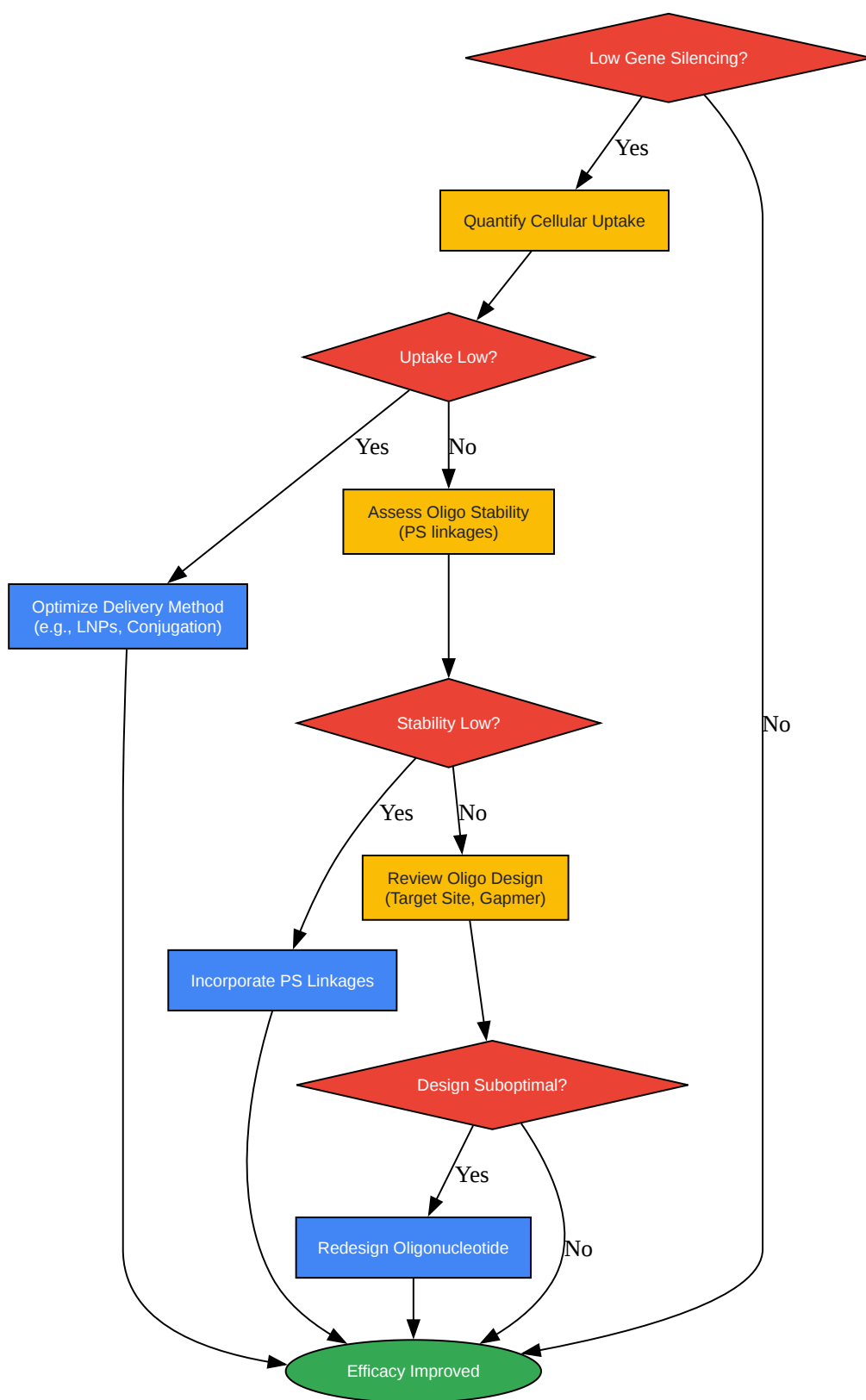

[Click to download full resolution via product page](#)

Caption: Troubleshooting logic for low 2'-F-ANA efficacy.

Need Custom Synthesis?

BenchChem offers custom synthesis for rare earth carbides and specific isotopic labeling.

Email: info@benchchem.com or [Request Quote Online](#).

References

- 1. Design and enhanced gene silencing activity of spherical 2'-fluoroarabinose nucleic acids (FANA-SNAs) - PMC [[pmc.ncbi.nlm.nih.gov](https://pubmed.ncbi.nlm.nih.gov/)]
- 2. Cellular Uptake and Intracellular Trafficking of Oligonucleotides - PMC [[pmc.ncbi.nlm.nih.gov](https://pubmed.ncbi.nlm.nih.gov/)]
- 3. Antisense 2'-Deoxy, 2'-Fluoroarabino Nucleic Acid (2'F-ANA) Oligonucleotides: In Vitro Gymnotic Silencers of Gene Expression Whose Potency Is Enhanced by Fatty Acids - PMC [[pmc.ncbi.nlm.nih.gov](https://pubmed.ncbi.nlm.nih.gov/)]
- 4. Advancing oligonucleotide therapeutics: conjugation strategies for extrahepatic delivery [insights.bio]
- 5. academic.oup.com [academic.oup.com]
- 6. glenresearch.com [glenresearch.com]
- 7. academic.oup.com [academic.oup.com]
- 8. 2'-Deoxy-2'-fluoro- β -d-arabinonucleic acid (2'F-ANA) modified oligonucleotides (ON) effect highly efficient, and persistent, gene silencing - PMC [[pmc.ncbi.nlm.nih.gov](https://pubmed.ncbi.nlm.nih.gov/)]
- 9. Collection - Fluorinated Lipid Nanoparticles for Enhancing mRNA Delivery Efficiency - ACS Nano - Figshare [acs.figshare.com]
- 10. Fluorinated Lipid Nanoparticles for Enhancing mRNA Delivery Efficiency - PubMed [pubmed.ncbi.nlm.nih.gov]
- 11. 2'-Deoxy-2'-fluoro- β -d-arabinonucleosides and oligonucleotides (2'F-ANA): synthesis and physicochemical studies - PMC [[pmc.ncbi.nlm.nih.gov](https://pubmed.ncbi.nlm.nih.gov/)]
- 12. 2'-Deoxy-2'-fluoro-beta-D-arabinonucleosides and oligonucleotides (2'F-ANA): synthesis and physicochemical studies - PubMed [pubmed.ncbi.nlm.nih.gov]
- 13. researchgate.net [researchgate.net]
- 14. researchgate.net [researchgate.net]
- 15. 2'-deoxy-2'-fluoro-beta-D-arabinonucleic acid (2'F-ANA) modified oligonucleotides (ON) effect highly efficient, and persistent, gene silencing - PubMed [pubmed.ncbi.nlm.nih.gov]

- [16. Improvements in siRNA properties mediated by 2'-deoxy-2'-fluoro-β-d-arabinonucleic acid \(FANA\) - PMC \[pmc.ncbi.nlm.nih.gov\]](#)
- [17. researchgate.net \[researchgate.net\]](#)
- [18. An Efficient Electroporation Protocol for the Genetic Modification of Mammalian Cells - PMC \[pmc.ncbi.nlm.nih.gov\]](#)
- To cite this document: BenchChem. [Technical Support Center: Enhancing Cellular Uptake of 2'-F-ANA-Based Therapeutics]. BenchChem, [2026]. [Online PDF]. Available at: [\[https://www.benchchem.com/product/b12846601/docs#technical-support-center-enhancing-cellular-uptake-of-2-f-ana-based-therapeutics\]](https://www.benchchem.com/product/b12846601/docs#technical-support-center-enhancing-cellular-uptake-of-2-f-ana-based-therapeutics)

Disclaimer & Data Validity:

The information provided in this document is for Research Use Only (RUO) and is strictly not intended for diagnostic or therapeutic procedures. While BenchChem strives to provide accurate protocols, we make no warranties, express or implied, regarding the fitness of this product for every specific experimental setup.

Technical Support: The protocols provided are for reference purposes. Unsure if this reagent suits your experiment?

Need Industrial/Bulk Grade? [Request Custom Synthesis Quote](#)

BenchChem

Our mission is to be the trusted global source of essential and advanced chemicals, empowering scientists and researchers to drive progress in science and industry.

Contact

Address: 3281 E Guasti Rd
Ontario, CA 91761, United States
Phone: (601) 213-4426
Email: info@benchchem.com

Contact our Ph.D. Support Team for a compatibility check