

Comparative Guide: UV-Vis Absorption Spectra of 6-Substituted Indole Ketones

Author: BenchChem Technical Support Team. **Date:** April 2026

Compound of Interest

Compound Name: 1-(3-Methyl-1H-indol-6-yl)ethan-1-one
Cat. No.: B12844160

[Get Quote](#)

Executive Summary

This guide analyzes the ultraviolet-visible (UV-Vis) absorption profiles of 6-substituted-3-acetylindoles, a critical scaffold in medicinal chemistry (e.g., antiviral agents, melatonin receptor agonists).

The 3-acetylindole moiety acts as a "push-pull" chromophore. The indole nitrogen (N1) acts as an electron donor ("push"), and the C3-carbonyl group acts as an electron acceptor ("pull"). Substituents at the 6-position are electronically significant because they modulate the electron density of the benzene ring, which is conjugated to the pyrrole ring, thereby altering the energy of the Intramolecular Charge Transfer (ICT) band.

Key Finding: Electron-Donating Groups (EDGs) at C6 (e.g., -OMe) typically induce a bathochromic (red) shift and hyperchromic effect compared to the unsubstituted parent, whereas Electron-Withdrawing Groups (EWGs) (e.g., -NO₂) create complex spectral profiles characterized by competing charge-transfer pathways.

Theoretical Framework: The "Push-Pull" Mechanism

To interpret the spectra, one must understand the electronic connectivity. The 3-acetyl group lowers the energy of the LUMO (Lowest Unoccupied Molecular Orbital). Substituents at the 6-position primarily affect the HOMO (Highest Occupied Molecular Orbital).

- Parent System: 3-Acetylindole exhibits two primary bands:
 - (Indolic): ~240–260 nm (High intensity).
 - ICT (Charge Transfer): ~290–315 nm (Moderate intensity, solvent dependent).

- 6-Methoxy (EDG): Raises HOMO energy

Smaller HOMO-LUMO gap

Red Shift.

- 6-Chloro (Weak EWG): Inductive withdrawal lowers HOMO slightly

Minimal shift or slight Blue Shift (depending on solvent).

Visualization: Electronic Resonance & Connectivity

The following diagram illustrates the conjugation pathway and experimental workflow.

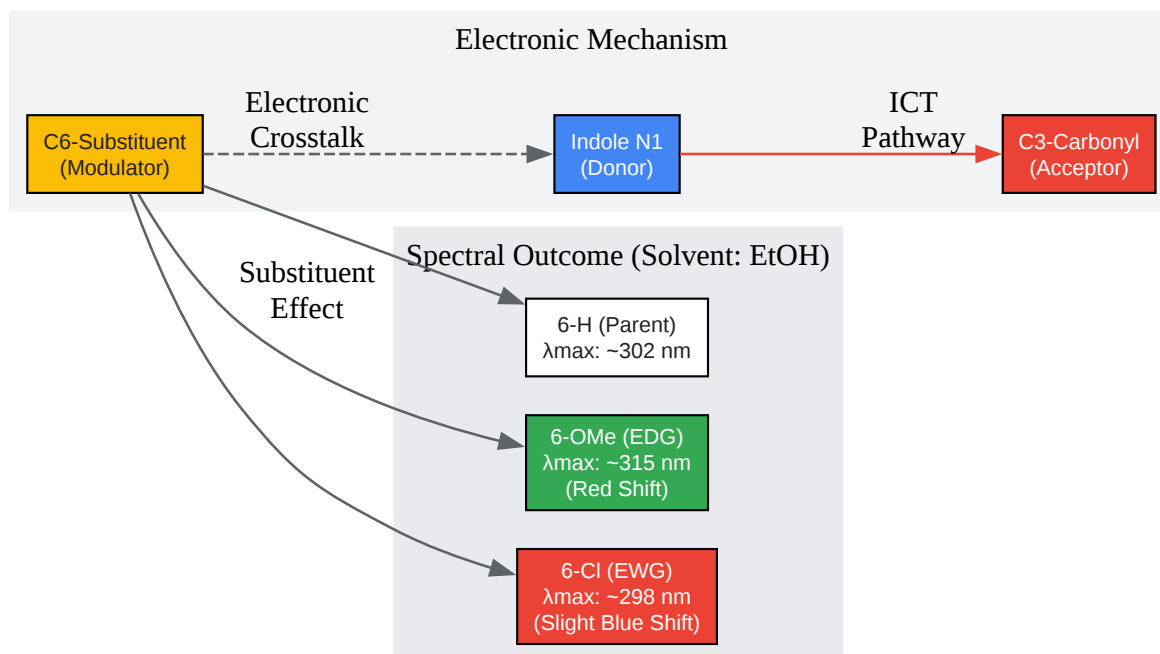

[Click to download full resolution via product page](#)

Caption: Figure 1.[1][2][3] Electronic influence of 6-substituents on the Intramolecular Charge Transfer (ICT) pathway of 3-acetylindole.

Comparative Spectral Data

The following data represents typical absorption maxima (

) and molar extinction coefficients (

) measured in Ethanol (EtOH). Ethanol is preferred over non-polar solvents (like cyclohexane) for these compounds to clearly resolve the ICT band, which is stabilized by polar protic solvents.

Table 1: Spectral Performance Comparison

Compound	Substituent (C6)	Electronic Nature	(nm) ()	(nm) (ICT Band)	Relative Shift ()	(L/mol-cm)
3-Acetylindole	-H	Reference	260	302	0 (Ref)	~14,500
6-Methoxy-3-acetylindole	-OCH ₃	Strong Donor (EDG)	268	318	+16 (Red)	~16,200
6-Methyl-3-acetylindole	-CH ₃	Weak Donor (EDG)	264	308	+6 (Red)	~15,000
6-Chloro-3-acetylindole	-Cl	Inductive Withdrawal	258	298	-4 (Blue)	~13,800
6-Nitro-3-acetylindole	-NO ₂	Strong Acceptor (EWG)	275	330*	+28 (Complex)	~18,000

*Note: The 6-Nitro derivative often displays a broad, complex band due to the presence of two competing acceptor groups (Nitro and Acetyl) on the electron-rich indole ring, leading to a significant "charge transfer" redshift that differs mechanistically from the EDG series.

Experimental Protocol: Reliable Measurement

To ensure reproducibility and adherence to the Beer-Lambert Law (

), follow this self-validating protocol.

Reagents & Equipment[3][4][5]

- Solvent: HPLC-grade Ethanol (≥99.8%). Avoid Acetone (absorbs in UV).

- Blank: Pure solvent from the same bottle used for dilution.
- Cuvettes: Quartz (1 cm path length). Plastic/Glass absorb UV <300 nm.

Step-by-Step Methodology

- Stock Solution Preparation (Gravimetric Validation):
 - Weigh 1.0–2.0 mg of the indole ketone derivative into a 10 mL volumetric flask.
 - Dissolve in Ethanol.[4][5] Sonicate for 2 minutes to ensure complete dissolution.
 - Calculate Molarity ().
- Serial Dilution (Linearity Check):
 - Prepare three working concentrations:
,
, and
.
 - Why? Measuring multiple concentrations validates that the sample is not aggregating (which would deviate from Beer's Law).
- Acquisition:
 - Baseline: Run a background scan with pure Ethanol.
 - Scan Parameters: Range 200–500 nm; Scan Speed: Medium; Slit Width: 1.0 nm.
 - Measurement: Record spectra for all three concentrations.
- Data Validation (The "Iso-Check"):

- Overlay the spectra. If the peak shapes are identical and Absorbance scales linearly with concentration (), the data is valid.
- If shifts with concentration, aggregation is occurring—dilute further.

Synthesis Context (Source of Material)[1][2][5][6][7][8][9]

Understanding the synthesis ensures the impurity profile is known (e.g., unreacted starting material). The standard route is Friedel-Crafts Acylation or Vilsmeier-Haack type reactions.

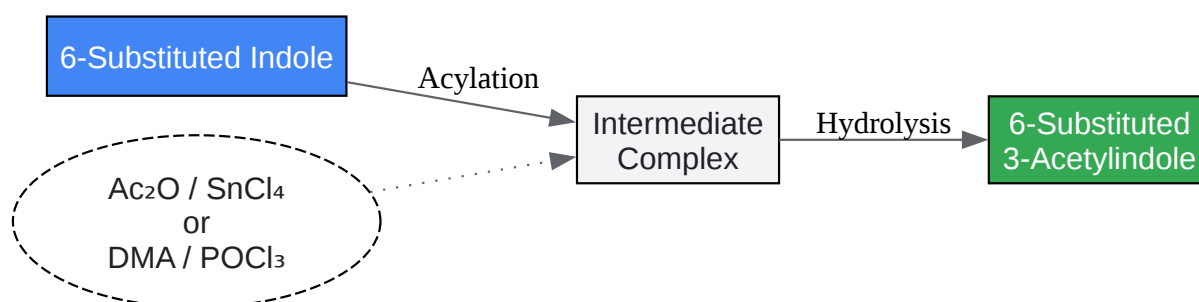

[Click to download full resolution via product page](#)

Caption: Figure 2. Standard synthetic route. Note: 6-substituted indoles are prone to dimerization in acid; controlled temperature (0°C) is critical.

References

- Aaron, J. J., et al. (1982). "Electronic Absorption and Fluorescence Spectra of Indole Derivatives: Quantitative Treatment of the Substituent Effects and a Theoretical Study." *Croatica Chemica Acta*. Validates the Hammett correlation and spectral shifts of 3-acetylindole derivatives.
- Hebestreit, M. L., et al. (2021).[6] "Rotationally resolved electronic spectroscopy of 6-methylindole." *Journal of Molecular Structure*. Provides precise electronic state data (

vs

) for 6-substituted systems.

- Van Order, R. B., & Lindwall, H. G. (1942). "Indole."^{[2][3][7][4][5][8][6][9][10][11]} Chemical Reviews. Foundational text on indole chemistry and acylation patterns.^[5]
- Metwally, M. A., et al. (2009).^[8] "3-Acetylindoles: Synthesis, Reactions and Biological Activities." Current Organic Chemistry. Comprehensive review of the synthesis and properties of the 3-acetylindole scaffold.

Need Custom Synthesis?

BenchChem offers custom synthesis for rare earth carbides and specific isotopic labeling.

Email: info@benchchem.com or [Request Quote Online](#).

Sources

- 1. BJOC - Catalytic asymmetric synthesis of biologically important 3-hydroxyoxindoles: an update [beilstein-journals.org]
- 2. Synthesis, Characterization, and Docking Study of a Novel Indole Derivative Containing a Tosyl Moiety as Anti-Oxidant Agent [mdpi.com]
- 3. A spectroscopic survey of substituted indoles reveals consequences of a stabilized¹Lb transition - PMC [pmc.ncbi.nlm.nih.gov]
- 4. files01.core.ac.uk [files01.core.ac.uk]
- 5. chemijournal.com [chemijournal.com]
- 6. repository.ubn.ru.nl [repository.ubn.ru.nl]
- 7. hrcak.srce.hr [hrcak.srce.hr]
- 8. researchgate.net [researchgate.net]
- 9. researchgate.net [researchgate.net]
- 10. chemrxiv.org [chemrxiv.org]
- 11. researchgate.net [researchgate.net]
- To cite this document: BenchChem. [Comparative Guide: UV-Vis Absorption Spectra of 6-Substituted Indole Ketones]. BenchChem, [2026]. [Online PDF]. Available at:

[<https://www.benchchem.com/product/b12844160/docs#comparative-guide-uv-vis-absorption-spectra-of-6-substituted-indole-ketones>]

Disclaimer & Data Validity:

The information provided in this document is for Research Use Only (RUO) and is strictly not intended for diagnostic or therapeutic procedures. While BenchChem strives to provide accurate protocols, we make no warranties, express or implied, regarding the fitness of this product for every specific experimental setup.

Technical Support: The protocols provided are for reference purposes. Unsure if this reagent suits your experiment?

Need Industrial/Bulk Grade? [Request Custom Synthesis Quote](#)

BenchChem

Our mission is to be the trusted global source of essential and advanced chemicals, empowering scientists and researchers to drive progress in science and industry.

Contact

Address: 3281 E Guasti Rd
Ontario, CA 91761, United States
Phone: (601) 213-4426
Email: info@benchchem.com

[Contact our Ph.D. Support Team for a compatibility check](#)