

comparative study of methoxy-substituted bromothiophenes

Author: BenchChem Technical Support Team. **Date:** May 2026

Compound of Interest

Compound Name: 2-Bromo-5-methoxythiophene

CAS No.: 57070-77-6

Cat. No.: B1284175

[Get Quote](#)

Comparative Study: Methoxy-Substituted Bromothiophenes

From Instability to Utility: Navigating Regioisomerism in Thiophene Scaffolds

Executive Summary & Critical Safety Warning

Status: CRITICAL SAFETY ALERT regarding 2-Bromo-3-methoxythiophene.

Researchers utilizing methoxy-bromothiophenes must distinguish between regioisomers not just for Structure-Activity Relationship (SAR) reasons, but for laboratory safety.

- 2-Bromo-3-methoxythiophene: Highly unstable.^[1] Prone to spontaneous, exothermic autopolymerization (combustion) at room temperature due to a weak C–Br bond and radical propagation. Must be stored at -20°C or below, preferably in solution.
- 3-Bromo-4-methoxythiophene: Stable solid/oil. The preferred building block for introducing the methoxy-thiophene motif in drug discovery and PEDOT-derivative synthesis.

Structural & Reactivity Analysis[2]

The electronic interplay between the electron-rich thiophene ring, the strongly electron-donating methoxy group (+M effect), and the electron-withdrawing bromine (-I effect) dictates the reactivity profile.

Table 1: Comparative Profile of Key Isomers

Feature	2-Bromo-3-methoxythiophene	3-Bromo-4-methoxythiophene	2-Bromo-4-methoxythiophene
Structure	Ortho-substituted (Crowded)	Meta-substituted (Symmetric-like)	Meta-substituted (Distal)
Synthesis	Direct Bromination (NBS) or Lithiation of 3-OMe-thiophene	Nucleophilic Subst. of 3,4-dibromothiophene	Selective Lithiation or Debromination
Stability	LOW (Autopolymerizes)	HIGH (Stable intermediate)	MODERATE
Electronic State	Highly polarized; C2-Br bond weakened by C3-OMe	Balanced electron density	C2-Br bond stabilized relative to 2,3-isomer
Primary Use	Kinetic intermediate (use immediately)	Stable precursor (EDOT, Pharma)	Specialized SAR studies
Lithiation Site	C5 (blocked C2)	C2 or C5 (equivalent)	C5 (directed by OMe)

Mechanism of Instability (2-Bromo-3-methoxythiophene)

The instability of the 2,3-isomer arises from the "ortho-effect" where the electron-donating methoxy group at C3 significantly destabilizes the C2-Br bond.

- Initiation: Homolytic cleavage of the weak C2-Br bond generates a thiophene radical.
- Propagation: The radical attacks the C2=C3 double bond of a neighboring molecule.
- Termination: Formation of insoluble, dark conductive oligomers (poly-3-methoxythiophene-like structures) with release of HBr/Br₂, often leading to thermal runaway.

Synthesis Pathways & Logic

The choice of isomer dictates the synthetic strategy. You cannot simply "brominate" to get the 3,4-isomer; it requires a scaffold reconstruction approach.

Diagram 1: Divergent Synthesis Workflows

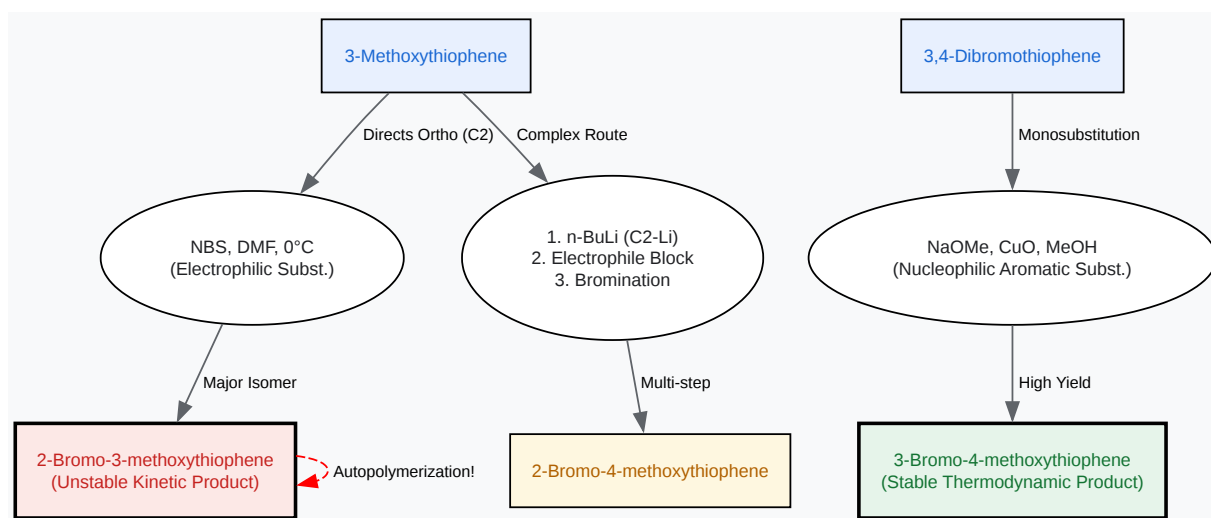

[Click to download full resolution via product page](#)

Caption: Divergent synthetic routes. Direct bromination yields the unstable 2,3-isomer, while nucleophilic substitution on the dibromo-scaffold yields the stable 3,4-isomer.

Experimental Protocols

Protocol A: Synthesis of 3-Bromo-4-methoxythiophene (The "Safe" Route)

Target: Stable scaffold for cross-coupling.

Reagents: 3,4-Dibromothiophene (1.0 eq), Sodium Methoxide (NaOMe, 3.0 eq), Copper(II) Oxide (CuO, 0.1 eq), Methanol/Pyridine (solvent).

- Setup: Flame-dry a 3-neck round-bottom flask equipped with a reflux condenser and magnetic stir bar.
- Charging: Add 3,4-dibromothiophene (e.g., 24.2 g, 100 mmol) and CuO (0.8 g, 10 mmol).
- Solvent: Add anhydrous MeOH (40 mL) and Pyridine (10 mL). Note: Pyridine acts as a ligand for Cu, enhancing the Ullmann-type substitution.
- Initiation: Add NaOMe (25% in MeOH, ~3 eq) dropwise.
- Reflux: Heat the mixture to reflux (approx. 70-80°C) for 12–16 hours. Monitor by GC-MS or TLC (Hexane/EtOAc 9:1).
 - Checkpoint: The starting material (dibromo) should disappear. If 3,4-dimethoxythiophene (bis-substituted) starts forming, stop immediately.
- Workup: Cool to RT. Filter through a Celite pad to remove copper salts. Concentrate the filtrate under reduced pressure.
- Extraction: Dilute residue with water and extract with diethyl ether (3x). Wash organics with 1M HCl (to remove pyridine), then brine. Dry over MgSO₄.
- Purification: Distillation under reduced pressure (bp ~85-90°C at 2 mmHg) or flash chromatography (Silica, 100% Hexanes → 5% EtOAc).
- Yield: Typically 65–75% as a colorless to pale yellow oil.

Protocol B: Stabilization & Handling of 2-Bromo-3-methoxythiophene

Target: If you absolutely require this isomer for specific substitution patterns.

- Synthesis: Bromination of 3-methoxythiophene with NBS in DMF at -10°C. Do not use elemental bromine () if possible, as HBr byproducts accelerate decomposition.

- Workup: Use a basic wash (NaHCO_3) immediately to neutralize any acid traces. Acid catalyzes the polymerization.
- Storage:
 - NEVER store neat (pure liquid) at room temperature.
 - Store as a solution: Dilute in Hexane or DCM (10-20% wt/vol).
 - Add Stabilizer: Add copper turnings or a radical scavenger (BHT) to the storage vial.
 - Temperature: -20°C or -80°C freezer.

Reactivity & Applications Data

Lithiation Regioselectivity (Directed Ortho Metalation - DoM)

The methoxy group is a powerful Directing Metalation Group (DMG).

- Substrate: 3-Methoxythiophene^[2]
- Reagent: n-BuLi / THF / -78°C
- Outcome: Lithiation occurs almost exclusively at C2 (Ortho to OMe, Alpha to Sulfur).
 - Implication: This makes accessing the 2,3-disubstituted pattern easy, but the 2,4-pattern difficult without blocking groups.

Table 2: ^1H NMR Chemical Shift Diagnostic (CDCl_3 , 400 MHz)

Proton Position	3-Methoxythiophene	2-Bromo-3-methoxythiophene	3-Bromo-4-methoxythiophene
H-2	6.22 ppm (d)	-- (Substituted)	7.24 ppm (d)
H-4	6.85 ppm (dd)	6.80 ppm (d)	-- (Substituted)
H-5	7.20 ppm (dd)	7.18 ppm (d)	6.25 ppm (d)
-OCH3	3.82 ppm (s)	3.88 ppm (s)	3.85 ppm (s)

Note: In 3-bromo-4-methoxythiophene, the H-2 is deshielded by the adjacent Br and S, appearing further downfield than H-5, which is ortho to the shielding OMe group.

Diagrammatic Logic: Regioselectivity

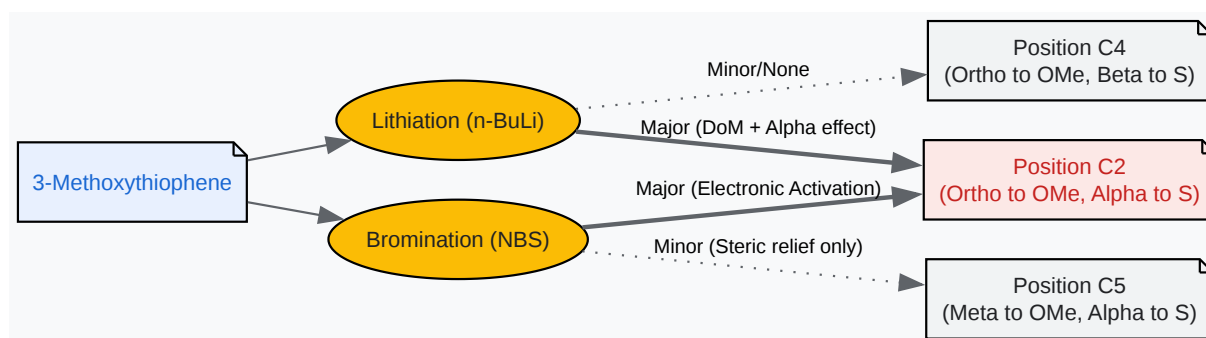

[Click to download full resolution via product page](#)

Caption: Regioselectivity map. Both lithiation and electrophilic bromination strongly favor the C2 position due to the synergistic activation by the Sulfur atom and the Methoxy group.

References

- Spontaneous Combustion of 2-Bromo-3-methoxythiophene. Nakamura, S. et al. [1] (2021). Detailed computational and experimental study on the radical oligomerization mechanism.
- Synthesis of 3,4-Dimethoxythiophene and Derivatives. Coffey, M. et al. (Synthetic Communications). Standard protocols for nucleophilic substitution on dibromothiophenes.

- Directed Ortho Metalation of Thiophenes. Snieckus, V. (Chem. Rev.). Comprehensive review of DMG effects in heterocyclic chemistry.
- Regioselective Bromination of Alkylthiophenes. Campaigne, E. et al. (J. Org. Chem.). Foundational work on NBS vs Br₂ selectivity.
- NMR Data for Thiophene Derivatives.

Need Custom Synthesis?

BenchChem offers custom synthesis for rare earth carbides and specific isotopic labeling.

Email: info@benchchem.com or [Request Quote Online](#).

Sources

- [1. riken.repo.nii.ac.jp](http://riken.repo.nii.ac.jp) [riken.repo.nii.ac.jp]
- [2. 2-\(Methoxycarbonyl\)thiophen-3-yl-diazonium Salts: Efficient Precursors for the Formation of C–C Bonds in Thiophene-Containing Heterocyclic Systems - PMC](#) [pmc.ncbi.nlm.nih.gov]
- [3. myers.faculty.chemistry.harvard.edu](http://myers.faculty.chemistry.harvard.edu) [myers.faculty.chemistry.harvard.edu]
- To cite this document: BenchChem. [comparative study of methoxy-substituted bromothiophenes]. BenchChem, [2026]. [Online PDF]. Available at: [<https://www.benchchem.com/product/b1284175/docs#comparative-study-of-methoxy-substituted-bromothiophenes>]

Disclaimer & Data Validity:

The information provided in this document is for Research Use Only (RUO) and is strictly not intended for diagnostic or therapeutic procedures. While BenchChem strives to provide accurate protocols, we make no warranties, express or implied, regarding the fitness of this product for every specific experimental setup.

Technical Support: The protocols provided are for reference purposes. Unsure if this reagent suits your experiment?

Need Industrial/Bulk Grade? [Request Custom Synthesis Quote](#)

BenchChem

Our mission is to be the trusted global source of essential and advanced chemicals, empowering scientists and researchers to drive progress in science and industry.

Contact

Address: 3281 E Guasti Rd

Ontario, CA 91761, United States

Phone: (601) 213-4426

Email: info@benchchem.com

[Contact our Ph.D. Support Team for a compatibility check](#)