

# Validation of 8-Allyloxyadenosine: A Comparative Guide for Researchers

**Author:** BenchChem Technical Support Team. **Date:** April 2026

## Compound of Interest

Compound Name: 8-Allyloxyadenosine

Cat. No.: B12830150

[Get Quote](#)

For researchers, scientists, and drug development professionals, the selection of selective chemical probes is paramount for the accurate validation of biological targets. This guide provides a comparative analysis of **8-Allyloxyadenosine**, a purine derivative, against other commonly used adenosine receptor ligands. Due to the limited publicly available data on the specific binding affinity and functional activity of **8-Allyloxyadenosine** at adenosine receptor subtypes, this guide focuses on presenting a framework for its evaluation and compares established research tools.

## Introduction to Adenosine Receptor Modulation

Adenosine receptors, a family of four G protein-coupled receptors (GPCRs) designated A1, A2A, A2B, and A3, are crucial regulators of a wide array of physiological processes. Their modulation by selective agonists and antagonists is a key area of research for therapeutic interventions in cardiovascular, inflammatory, neurological, and oncological diseases. The validation of any new chemical entity as a selective research tool for these receptors requires rigorous characterization of its binding affinity and functional activity at each subtype.

## Comparative Analysis of Adenosine Receptor Agonists

To properly validate **8-Allyloxyadenosine** as a selective research tool, its binding affinity (K<sub>i</sub>) and functional potency (EC<sub>50</sub>) at each of the four adenosine receptor subtypes would need to be determined and compared to established selective and non-selective ligands.

Table 1: Comparative Binding Affinities (K<sub>i</sub>, nM) of Selected Adenosine Receptor Agonists

Compound	A1 Receptor	A2A Receptor	A2B Receptor	A3 Receptor	Selectivity Profile
8-Allyloxyadenosine	Data not available	Data not available	Data not available	Data not available	-
NECA	14	20	2400 (EC <sub>50</sub> )	6.2	Non-selective agonist[1][2]
CGS-21680	290	27	>10000	88800	A2A selective agonist[3]
IB-MECA	54	56	Data not available	1.1	A3 selective agonist[4]
2-Cl-IB-MECA	>1000	>1000	Data not available	0.33	Highly A3 selective agonist[5]

Table 2: Comparative Functional Potencies (EC<sub>50</sub>, nM) of Selected Adenosine Receptor Agonists in cAMP Assays

Compound	A1/A3 Receptors (cAMP Inhibition)	A2A/A2B Receptors (cAMP Stimulation)
8-Allyloxyadenosine	Data not available	Data not available
NECA	Potent inhibitor	Potent stimulator (EC50 at A2A = 27.5 nM)
CGS-21680	Weakly active	Potent A2A stimulator (EC50 = 110 nM)
IB-MECA	Potent A3 inhibitor (EC50 = 0.82-1.2 $\mu$ M in cancer cells)	Weakly active

## Experimental Protocols for Validation

The validation of **8-Allyloxyadenosine** would require the following standard experimental procedures.

### Radioligand Binding Assays

Radioligand binding assays are essential for determining the affinity ( $K_i$ ) of a test compound for a specific receptor.

Objective: To determine the binding affinity of **8-Allyloxyadenosine** for human A1, A2A, A2B, and A3 adenosine receptors.

Materials:

- Cell membranes prepared from cell lines stably expressing each human adenosine receptor subtype (e.g., CHO or HEK293 cells).
- Radioligands selective for each receptor:
  - A1: [ $^3$ H]-DPCPX (antagonist) or [ $^3$ H]-CPA (agonist)
  - A2A: [ $^3$ H]-ZM241385 (antagonist) or [ $^3$ H]-CGS-21680 (agonist)
  - A2B: [ $^3$ H]-MRS1754 (antagonist)

- A3: [<sup>125</sup>I]-AB-MECA (agonist)
- **8-Allyloxyadenosine** and other reference compounds.
- Assay buffer (e.g., 50 mM Tris-HCl, pH 7.4).
- Glass fiber filters.
- Scintillation counter.

#### Procedure:

- Incubate cell membranes with a fixed concentration of the appropriate radioligand and varying concentrations of the unlabeled test compound (**8-Allyloxyadenosine**) or reference compounds.
- Allow the binding to reach equilibrium.
- Separate bound from free radioligand by rapid filtration through glass fiber filters.
- Wash the filters with ice-cold assay buffer to remove non-specifically bound radioligand.
- Measure the radioactivity retained on the filters using a scintillation counter.
- Determine the concentration of the test compound that inhibits 50% of the specific binding of the radioligand (IC<sub>50</sub>).
- Calculate the inhibitory constant (K<sub>i</sub>) using the Cheng-Prusoff equation:  $K_i = IC_{50} / (1 + [L]/K_d)$ , where [L] is the concentration of the radioligand and K<sub>d</sub> is its dissociation constant.

## Functional Assays: cAMP Accumulation

Functional assays are crucial to determine whether a compound acts as an agonist, antagonist, or inverse agonist and to quantify its potency (EC<sub>50</sub>) and efficacy.

Objective: To determine the functional activity of **8-Allyloxyadenosine** at human A1, A2A, A2B, and A3 adenosine receptors by measuring its effect on cyclic AMP (cAMP) levels.

#### Materials:

- Whole cells stably expressing each human adenosine receptor subtype.
- Forskolin (an adenylyl cyclase activator).
- **8-Allyloxyadenosine** and other reference compounds.
- cAMP assay kit (e.g., HTRF, ELISA, or AlphaScreen).

Procedure for A2A and A2B Receptors (Gs-coupled):

- Plate cells in a suitable microplate.
- Pre-incubate cells with varying concentrations of **8-Allyloxyadenosine** or a reference agonist.
- Stimulate adenylyl cyclase with a sub-maximal concentration of forskolin (optional, to amplify the signal).
- Lyse the cells and measure the intracellular cAMP concentration using a commercial assay kit.
- Plot the cAMP concentration against the log of the agonist concentration to determine the EC50 value.

Procedure for A1 and A3 Receptors (Gi-coupled):

- Plate cells in a suitable microplate.
- Pre-incubate cells with varying concentrations of **8-Allyloxyadenosine** or a reference agonist.
- Stimulate adenylyl cyclase with a fixed concentration of forskolin to induce cAMP production.
- Lyse the cells and measure the intracellular cAMP concentration.
- An agonist will inhibit the forskolin-stimulated cAMP production. Plot the percentage of inhibition against the log of the agonist concentration to determine the EC50 value.

## Visualizing Signaling Pathways and Workflows

To aid in the conceptualization of the experimental processes and underlying biological mechanisms, the following diagrams are provided.

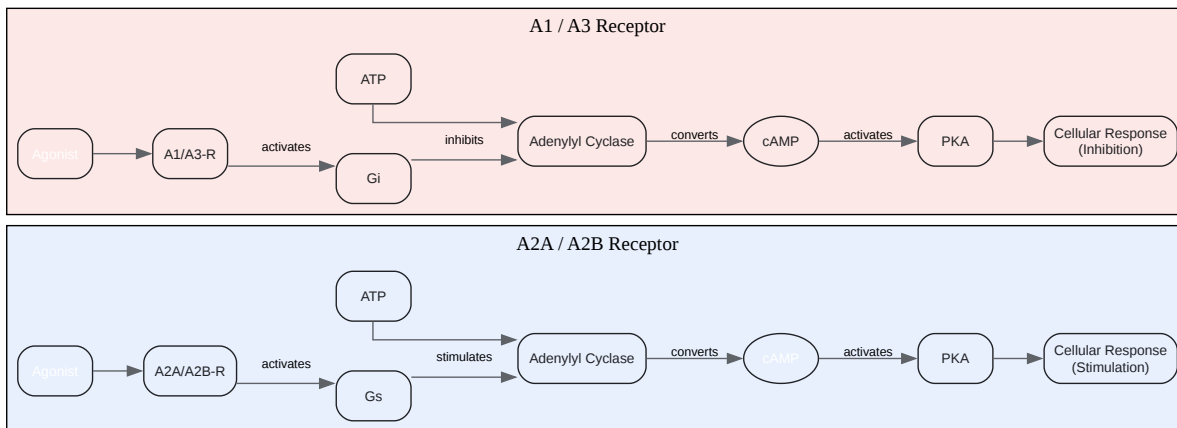

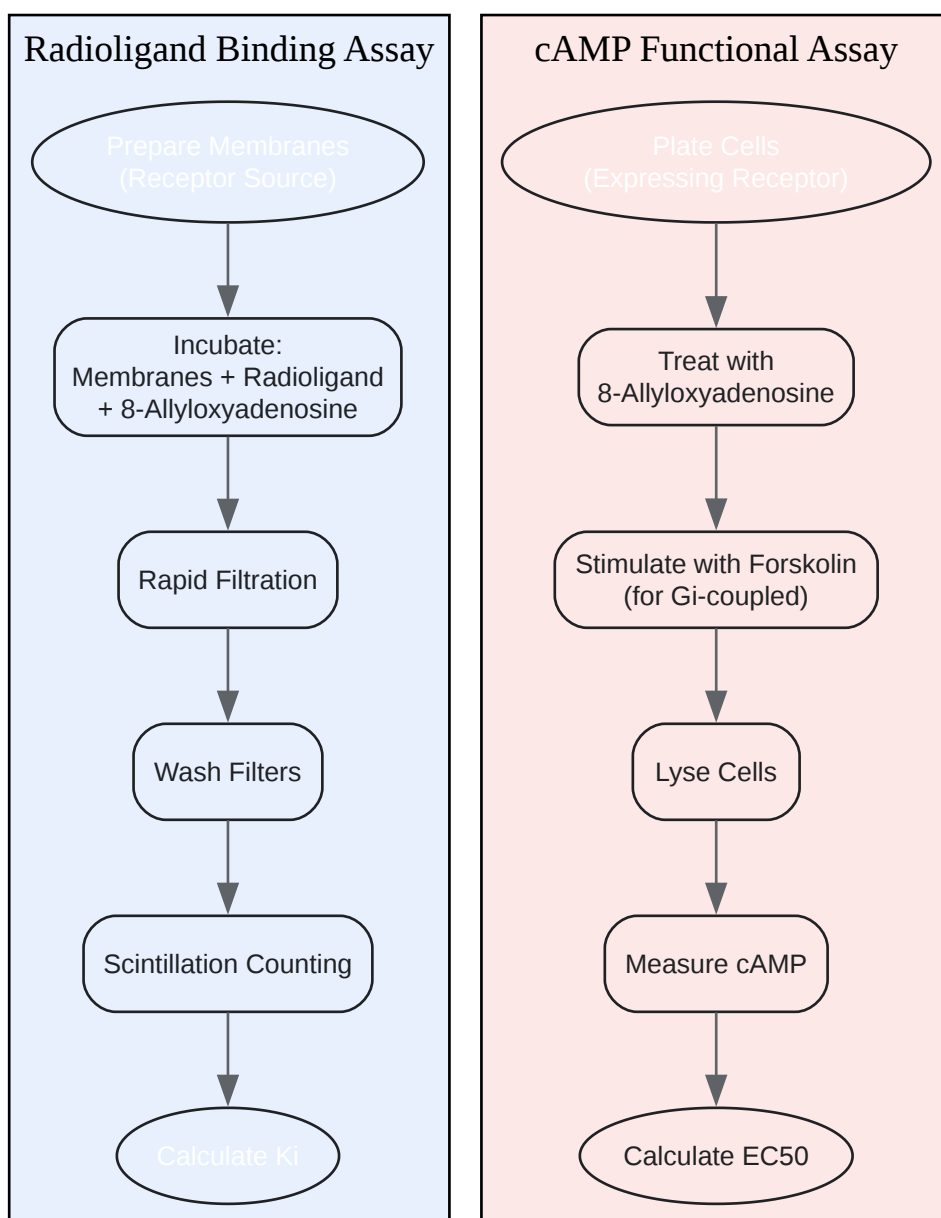

[Click to download full resolution via product page](#)

**Need Custom Synthesis?**

BenchChem offers custom synthesis for rare earth carbides and specific isotopic labeling.

Email: [info@benchchem.com](mailto:info@benchchem.com) or [Request Quote Online](#).

**References**

- [1. Recent developments in adenosine receptor ligands and their potential as novel drugs - PMC \[pmc.ncbi.nlm.nih.gov\]](#)
- [2. Structure-affinity relationships of adenosine A2B receptor ligands - PubMed \[pubmed.ncbi.nlm.nih.gov\]](#)
- [3. Adenosine A2A receptor dynamics studied with the novel fluorescent agonist Alexa488-APEC - PMC \[pmc.ncbi.nlm.nih.gov\]](#)
- [4. ptabdata.blob.core.windows.net \[ptabdata.blob.core.windows.net\]](#)
- [5. innoprot.com \[innoprot.com\]](#)
- To cite this document: BenchChem. [Validation of 8-Allyloxyadenosine: A Comparative Guide for Researchers]. BenchChem, [2026]. [Online PDF]. Available at: [\[https://www.benchchem.com/product/b12830150/docs#validation-of-8-allyloxyadenosine-a-comparative-guide-for-researchers\]](https://www.benchchem.com/product/b12830150/docs#validation-of-8-allyloxyadenosine-a-comparative-guide-for-researchers)

---

**Disclaimer & Data Validity:**

The information provided in this document is for Research Use Only (RUO) and is strictly not intended for diagnostic or therapeutic procedures. While BenchChem strives to provide accurate protocols, we make no warranties, express or implied, regarding the fitness of this product for every specific experimental setup.

**Technical Support:** The protocols provided are for reference purposes. Unsure if this reagent suits your experiment?

**Need Industrial/Bulk Grade?** [Request Custom Synthesis Quote](#)

## BenchChem

Our mission is to be the trusted global source of essential and advanced chemicals, empowering scientists and researchers to drive progress in science and industry.

### Contact

Address: 3281 E Guasti Rd  
Ontario, CA 91761, United States  
Phone: (601) 213-4426  
Email: [info@benchchem.com](mailto:info@benchchem.com)

Contact our Ph.D. Support Team for a compatibility check