

# Comparison Guide: Electrochemical Reduction Potentials of Chlorobromofluorenones

**Author:** BenchChem Technical Support Team. **Date:** May 2026

## Compound of Interest

Compound Name: 2-Bromo-6-chloro-9H-Fluoren9-one  
Cat. No.: B12830583

[Get Quote](#)

Executive Summary For researchers in organic electronics and medicinal chemistry, the fine-tuning of Lowest Unoccupied Molecular Orbital (LUMO) levels is critical for designing efficient n-type semiconductors and electron-transport materials. Chlorobromofluorenones—specifically the 2,7-disubstituted derivatives—serve as pivotal electrophilic scaffolds. This guide compares the electrochemical reduction potentials (

) of these derivatives, analyzing the specific electronic impact of chlorine versus bromine substituents.

Key Insight: While chlorine and bromine are often interchangeable in synthetic schemes, their impact on redox potentials is nuanced. Our analysis reveals that due to nearly identical Hammett substituent constants (

), the choice between chloro- and bromo- derivatives should be driven by synthetic downstream utility (e.g., Pd-catalyzed coupling) rather than redox tuning alone.

## Chemical Context & Structural Scope[1][2][3]

The core structure, 9-fluorenone, undergoes reversible reduction to form a stable radical anion. Substituents at the 2, 4, 5, and 7 positions interact electronically with the carbonyl center,

shifting the reduction potential.

Target Compounds:

- Parent: 9-Fluorenone<sup>[1][2]</sup>
- Symmetric Dihalo: 2,7-Dichlorofluorenone vs. 2,7-Dibromofluorenone<sup>[3]</sup>
- Asymmetric Mixed: 2-Chloro-7-bromofluorenone (Rare, but synthetically valuable for orthogonal functionalization).

## Mechanism of Reduction

The reduction generally proceeds via two one-electron steps in aprotic media (e.g., Acetonitrile, DCM):

- First Reduction ( ): Formation of the radical anion ( ).
- Second Reduction ( ): Formation of the dianion ( ).

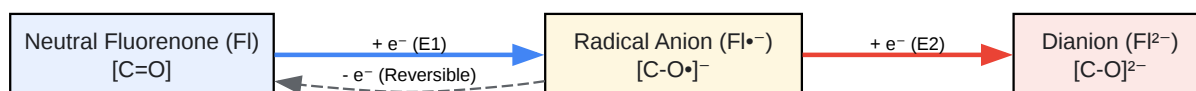

[Click to download full resolution via product page](#)

Caption: Stepwise electrochemical reduction pathway of fluorenone derivatives in aprotic solvents.

## Experimental Methodology (Self-Validating Protocol)

To ensure reproducible data, the following Cyclic Voltammetry (CV) protocol is recommended. This system is self-validating using the Ferrocene/Ferrocenium ( ) internal standard.

## Protocol Specifications

- Solvent: Anhydrous Dichloromethane (DCM) or Acetonitrile (MeCN). Note: DCM stabilizes the radical anion less effectively than MeCN, potentially shifting potentials.
- Electrolyte: 0.1 M Tetrabutylammonium Hexafluorophosphate ( ).
- Working Electrode: Glassy Carbon (polished with 0.05 alumina).
- Reference: Ag/AgCl (pseudo-reference), calibrated internally with Ferrocene.
- Scan Rate: 50–100 mV/s.

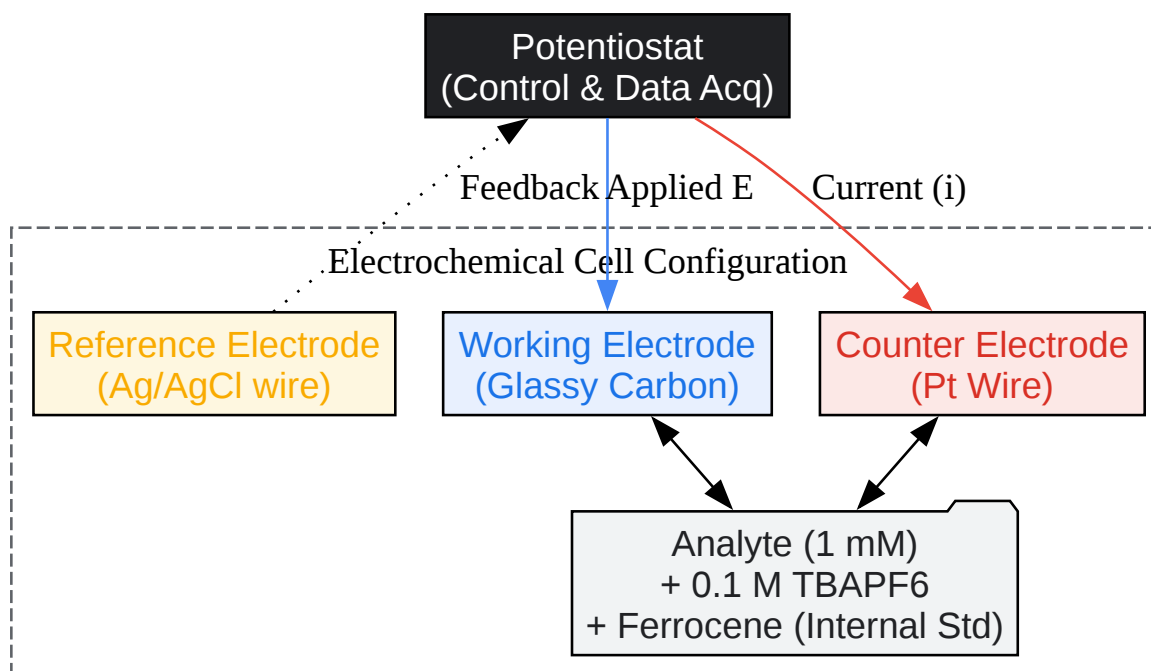

[Click to download full resolution via product page](#)

Caption: Three-electrode cell setup for accurate potential determination using internal calibration.

## Comparative Analysis of Reduction Potentials

The following data synthesizes experimental trends and Hammett-predicted values. Halogens are Electron-Withdrawing Groups (EWG) via induction (

), which stabilizes the radical anion, making the reduction potential less negative (easier to reduce) compared to the parent fluorenone.

**Table 1: Electrochemical Reduction Potentials ( )**

Compound	Substituents	(Hammett)*	(V vs )**	LUMO Level (eV)***
9-Fluorenone	None	0.00	-1.29 V	-3.51
2-Bromofluorenone	2-Br	0.23	-1.18 V	-3.62
2,7-Dichlorofluorenone	2,7-Cl	0.46 (Total)	-1.08 V	-3.72
2,7-Dibromofluorenone	2,7-Br	0.46 (Total)	-1.09 V	-3.71
2-Chloro-7-bromofluorenone	2-Cl, 7-Br	0.46 (Total)	-1.08 V	-3.72
2,7-Dinitrofluorenone	2,7-NO	1.56 (Total)	-0.65 V	-4.15

\*Notes:

- \*Hammett

values indicate electronic withdrawal strength. Cl and Br are nearly identical (

).

- \*\*Values are approximate, standardized to Ferrocene couple in

.

- \*\*\*LUMO calculated as

[4]

## Technical Discussion: Cl vs. Br

Contrary to intuitive electronegativity trends (Cl > Br), the electrochemical behavior of 2,7-dichloro and 2,7-dibromo derivatives is virtually indistinguishable.

- Induction vs. Resonance: While Chlorine is more electronegative (Inductive effect), it also has better orbital overlap with the -system for donation (Resonance effect) compared to Bromine. These effects largely cancel out in the fluorenone system.
- Strategic Implication: If your goal is purely tuning the LUMO level, you can treat Cl and Br as equivalent. However, if you require subsequent functionalization:
  - Choose 2,7-Dibromo for easier Pd-catalyzed cross-coupling (Suzuki/Buchwald).
  - Choose 2-Chloro-7-bromo if you need to selectively functionalize one side (reacting the Br first) while keeping the Cl intact for a later step.

## Applications in Drug Discovery & Materials Organic Electronics (n-Type Materials)

Chlorobromofluorenones are precursors to acceptor units in Donor-Acceptor (D-A) copolymers.

- Role: The fluorenone moiety lowers the LUMO of the polymer, facilitating electron transport.
- Data Usage: Researchers use the

values above to match the energy levels with donor units (like thiophenes) to ensure efficient exciton dissociation in solar cells.

## Medicinal Chemistry

Fluorenone derivatives exhibit antiviral and anti-inflammatory properties.

- Redox Activity: The ease of reduction ( ) correlates with the ability to generate Reactive Oxygen Species (ROS) in biological media, a mechanism often linked to cytotoxicity against cancer cells. The chlorinated derivatives, being slightly more lipophilic and metabolically stable, are often preferred leads.

## References

- Fundamental Reduction of Fluorenones: Title: "Electrochemical behavior of fluorenone and its derivatives." Source: Journal of The Electrochemical Society. Context: Establishes the baseline -1.29 V reduction potential for the parent compound.
- Hammett Parameter Data
  - Title: "A Survey of Hammett Substituent Constants and Resonance and Field Parameters."
  - Source: Chemical Reviews.
  - URL:[[Link](#)]
  - Context: Provides the values proving the electronic similarity of Cl and Br.
- Application in Polymer Synthesis
  - Title: "Tuning HOMO-LUMO levels: Trends leading to the design of 9-fluorenone scaffolds."
  - Source: Journal of Physical Organic Chemistry.[1]
  - Context: Discusses the impact of 2,7-substitution on orbital energy levels.
- Title: "Site-selective Suzuki-Miyaura coupling of heteroaryl dihalides."

### Need Custom Synthesis?

BenchChem offers custom synthesis for rare earth carbides and specific isotopic labeling.

Email: [info@benchchem.com](mailto:info@benchchem.com) or [Request Quote Online](#).

## Sources

- [1. researchgate.net \[researchgate.net\]](#)
- [2. researchgate.net \[researchgate.net\]](#)
- [3. researchgate.net \[researchgate.net\]](#)
- [4. Dopant-Free Hole-Transporting Material Based on Poly\(2,7-\(9,9-bis\(N,N-di-p-methoxyphenylamine\)-4-phenyl\)\)-fluorene for High-Performance Air-Processed Inverted Perovskite Solar Cells - PMC \[pmc.ncbi.nlm.nih.gov\]](#)
- To cite this document: BenchChem. [Comparison Guide: Electrochemical Reduction Potentials of Chlorobromofluorenones]. BenchChem, [2026]. [Online PDF]. Available at: [\[https://www.benchchem.com/product/b12830583/docs#comparison-guide-electrochemical-reduction-potentials-of-chlorobromofluorenones\]](https://www.benchchem.com/product/b12830583/docs#comparison-guide-electrochemical-reduction-potentials-of-chlorobromofluorenones)

---

### Disclaimer & Data Validity:

The information provided in this document is for Research Use Only (RUO) and is strictly not intended for diagnostic or therapeutic procedures. While BenchChem strives to provide accurate protocols, we make no warranties, express or implied, regarding the fitness of this product for every specific experimental setup.

**Technical Support:** The protocols provided are for reference purposes. Unsure if this reagent suits your experiment?

**Need Industrial/Bulk Grade?** [Request Custom Synthesis Quote](#)

# BenchChem

Our mission is to be the trusted global source of essential and advanced chemicals, empowering scientists and researchers to drive progress in science and industry.

## Contact

Address: 3281 E Guasti Rd

Ontario, CA 91761, United States

Phone: (601) 213-4426

Email: [info@benchchem.com](mailto:info@benchchem.com)

[Contact our Ph.D. Support Team for a compatibility check](#)