

Preventing over-alkylation in subsequent reaction steps

Author: BenchChem Technical Support Team. **Date:** May 2026

Compound of Interest

Compound Name:	<i>tert</i> -Butyl 4-(benzylamino)piperidine-1-carboxylate
CAS No.:	206273-87-2
Cat. No.:	B1283076

[Get Quote](#)

Technical Support Center: Alkylation Reactions

This technical support center provides troubleshooting guidance and frequently asked questions to help researchers, scientists, and drug development professionals prevent over-alkylation in subsequent reaction steps.

Frequently Asked Questions (FAQs)

Q1: What is over-alkylation and why does it occur?

Over-alkylation is a common side reaction where the intended product of an alkylation reaction undergoes further alkylation, leading to the formation of undesired, more substituted products. This is particularly prevalent in the N-alkylation of amines. The primary reason for this is that the product amine is often more nucleophilic than the starting amine. For example, a primary amine is more nucleophilic than ammonia, and a secondary amine is more nucleophilic than a primary amine.^[1] This increased nucleophilicity makes the product more reactive towards the

alkylating agent than the starting material, resulting in a mixture of products and a lower yield of the desired compound.[1][2]

Q2: How does the structure of the reactants affect over-alkylation?

The structure of both the amine and the alkylating agent plays a significant role. The nucleophilicity of the amine increases with the number of electron-donating alkyl groups, making secondary amines more reactive than primary amines.[2] However, steric hindrance can counteract this effect. For instance, the formation of tertiary amines from secondary amines can be less prone to over-alkylation into quaternary salts due to increased steric bulk around the nitrogen atom.[1]

Q3: What are the primary strategies to prevent over-alkylation?

Several strategies can be employed to control the extent of alkylation and favor the desired mono-alkylated product. These include:

- Reductive Amination: This is a highly reliable method that involves the reaction of an amine with an aldehyde or ketone to form an imine, which is then reduced to the desired alkylated amine.[1][2]
- Use of Protecting Groups: A protecting group can be introduced to temporarily block one of the reactive sites on the starting material, directing the alkylation to the desired position.[2][3]
- Sulfonamide Synthesis: The primary amine is first converted to a sulfonamide, which can be mono-alkylated and then deprotected to yield the secondary amine.[2]
- Controlling Reaction Conditions: Carefully optimizing reaction parameters such as stoichiometry, temperature, and the rate of addition of reagents can significantly improve selectivity.[3]
- Alternative Methods: Other synthetic routes like the Gabriel synthesis can be adapted to synthesize secondary amines while avoiding over-alkylation.[2] A recent approach involves the use of N-aminopyridinium salts as ammonia surrogates for self-limiting alkylation.[4][5]

Troubleshooting Guide: Over-Alkylation in Amine Synthesis

This guide provides a systematic approach to troubleshooting and optimizing N-alkylation reactions to minimize the formation of over-alkylated byproducts.

Issue: Formation of multiple alkylated products (e.g., tertiary amine and quaternary ammonium salt when targeting a secondary amine).

Potential Cause: The secondary amine product is more nucleophilic and is reacting faster than the primary amine starting material.[\[2\]](#)

Solutions:

Strategy	Description	Key Considerations
Stoichiometry Control	Use a large excess (5-10 equivalents) of the primary amine relative to the alkylating agent. This statistically favors the reaction of the alkylating agent with the more abundant primary amine.[2]	This approach can be atom-inefficient and may require challenging separation of the excess starting amine from the product.[3]
Slow Addition	Add the alkylating agent dropwise to the reaction mixture. This maintains a low concentration of the alkylating agent, which can favor mono-alkylation.[2]	Requires careful control of addition rate and may prolong the reaction time.
Temperature Control	Lowering the reaction temperature can sometimes help to control the reaction rate and improve selectivity towards mono-alkylation.[2][4]	May lead to significantly longer reaction times or incomplete conversion.
Solvent Choice	Using a less polar solvent can sometimes reduce the rate of the second alkylation.[2]	The choice of solvent must also ensure sufficient solubility of the reactants.
Base Selection	The choice of base can influence the selectivity. Consider using a milder base or a specific base known to favor mono-alkylation, such as cesium hydroxide or cesium carbonate.[2]	The optimal base will be substrate-dependent.

If optimizing the above conditions fails to provide the desired selectivity, consider a more robust synthetic strategy as outlined below.

Alternative Synthetic Protocols to Prevent Over-Alkylation

Reductive Amination

This is one of the most effective methods for the controlled synthesis of secondary amines.[1]
[2]

Experimental Protocol:

- Step 1: Imine Formation
 - Materials: Primary amine (1.0 mmol), Aldehyde or Ketone (1.2 mmol), Solvent (e.g., Dichloromethane (DCM) or 1,2-Dichloroethane (DCE)), Dehydrating agent (e.g., anhydrous MgSO_4 or molecular sieves).
 - Procedure:
 - Dissolve the primary amine (1.0 mmol) and the aldehyde or ketone (1.2 mmol) in the chosen solvent.
 - Add a dehydrating agent to remove the water formed during the reaction and drive the equilibrium towards imine formation.[2]
 - Stir the mixture at room temperature for 1-2 hours to allow for the formation of the imine intermediate.[1]
- Step 2: Reduction
 - Materials: Reducing agent (e.g., Sodium triacetoxyborohydride (STAB) (1.5 mmol)).
 - Procedure:
 - Add the reducing agent portion-wise to the reaction mixture containing the imine.[1]
STAB is a mild and selective reagent for this transformation.[2]
 - Continue stirring at room temperature and monitor the reaction by TLC or LC-MS until the starting materials are consumed (typically 1-12 hours).

- Upon completion, quench the reaction by the slow addition of a saturated aqueous solution of sodium bicarbonate (NaHCO_3).^[1]
- Separate the organic layer, and extract the aqueous layer with the solvent.
- Combine the organic layers, dry over anhydrous sodium sulfate (Na_2SO_4), filter, and concentrate under reduced pressure.
- Purify the crude product by column chromatography if necessary.^[1]

Protecting Group Strategy

This method involves the protection of the primary amine, followed by alkylation and deprotection.

Experimental Protocol:

- Step 1: Protection (Boc Protection Example)
 - Materials: Primary amine (1.0 mmol), Di-tert-butyl dicarbonate (Boc_2O) (1.1 mmol), Base (e.g., Triethylamine (TEA) or N,N-Diisopropylethylamine (DIPEA)) (1.5 mmol), Solvent (e.g., Dichloromethane (DCM) or Tetrahydrofuran (THF)).
 - Procedure:
 - Dissolve the primary amine (1.0 mmol) in the chosen solvent.
 - Add the base to the solution.
 - Add a solution of Boc_2O in the same solvent dropwise to the amine solution at 0 °C.
 - Allow the reaction mixture to warm to room temperature and stir for 2-12 hours.
 - Monitor the reaction by TLC or LC-MS.
 - Once the reaction is complete, dilute with water and extract the product with an organic solvent.

- Wash the combined organic layers with brine, dry over anhydrous Na_2SO_4 , filter, and concentrate in vacuo.
- Step 2: Alkylation
 - Materials: Boc-protected amine (1.0 mmol), Strong base (e.g., Sodium hydride (NaH)) (1.2 mmol), Alkylating agent (e.g., Alkyl halide) (1.2 mmol), Anhydrous solvent (e.g., THF or DMF).
 - Procedure:
 - Dissolve the Boc-protected amine (1.0 mmol) in the anhydrous solvent under an inert atmosphere.
 - Cool the solution to 0 °C and add the strong base portion-wise.
 - Stir for 30 minutes at 0 °C, then add the alkylating agent.
 - Allow the reaction to warm to room temperature and stir until completion (monitored by TLC or LC-MS).
 - Carefully quench the reaction with a saturated aqueous solution of ammonium chloride (NH_4Cl).
 - Extract the product with an organic solvent, dry the combined organic layers over Na_2SO_4 , filter, and concentrate.
- Step 3: Deprotection
 - Materials: Alkylated Boc-protected amine, Acid (e.g., Trifluoroacetic acid (TFA) or Hydrochloric acid (HCl) in an organic solvent).
 - Procedure:
 - Dissolve the alkylated Boc-protected amine in a suitable solvent (e.g., DCM).
 - Add an excess of the acid (e.g., 20-50% TFA in DCM).

- Stir at room temperature for 1-4 hours until the deprotection is complete (monitored by TLC or LC-MS).
- Remove the solvent and excess acid under reduced pressure.
- Neutralize with a base and extract the final secondary amine product.

Visualizations

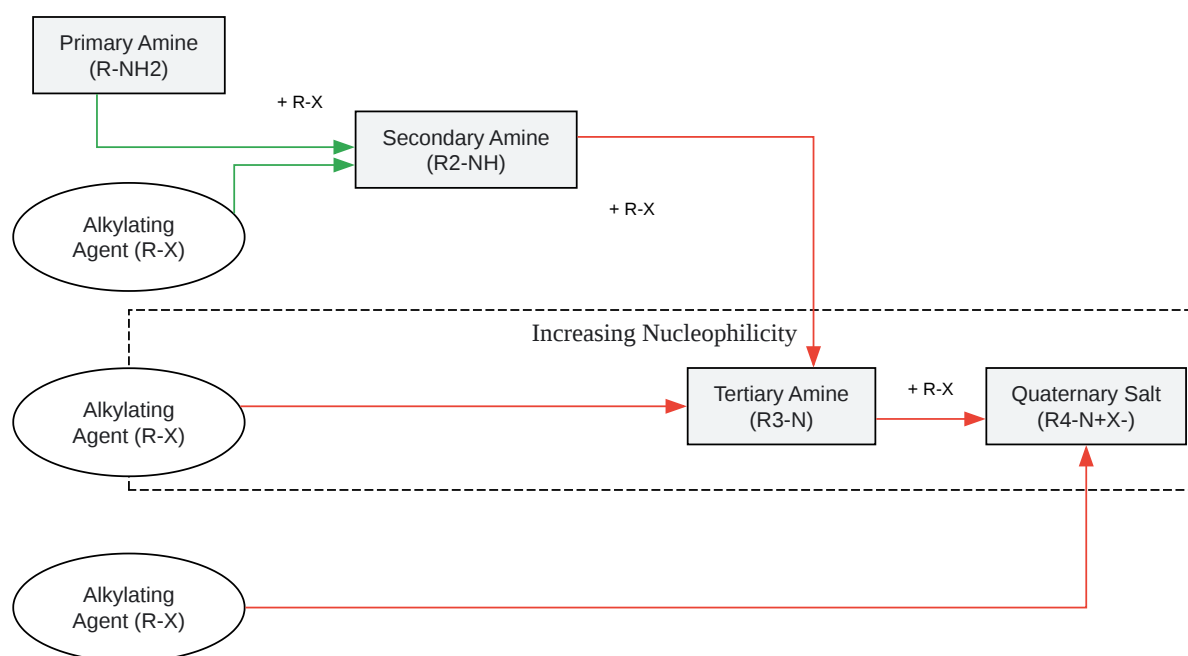

[Click to download full resolution via product page](#)

Caption: The over-alkylation cascade in amine synthesis.

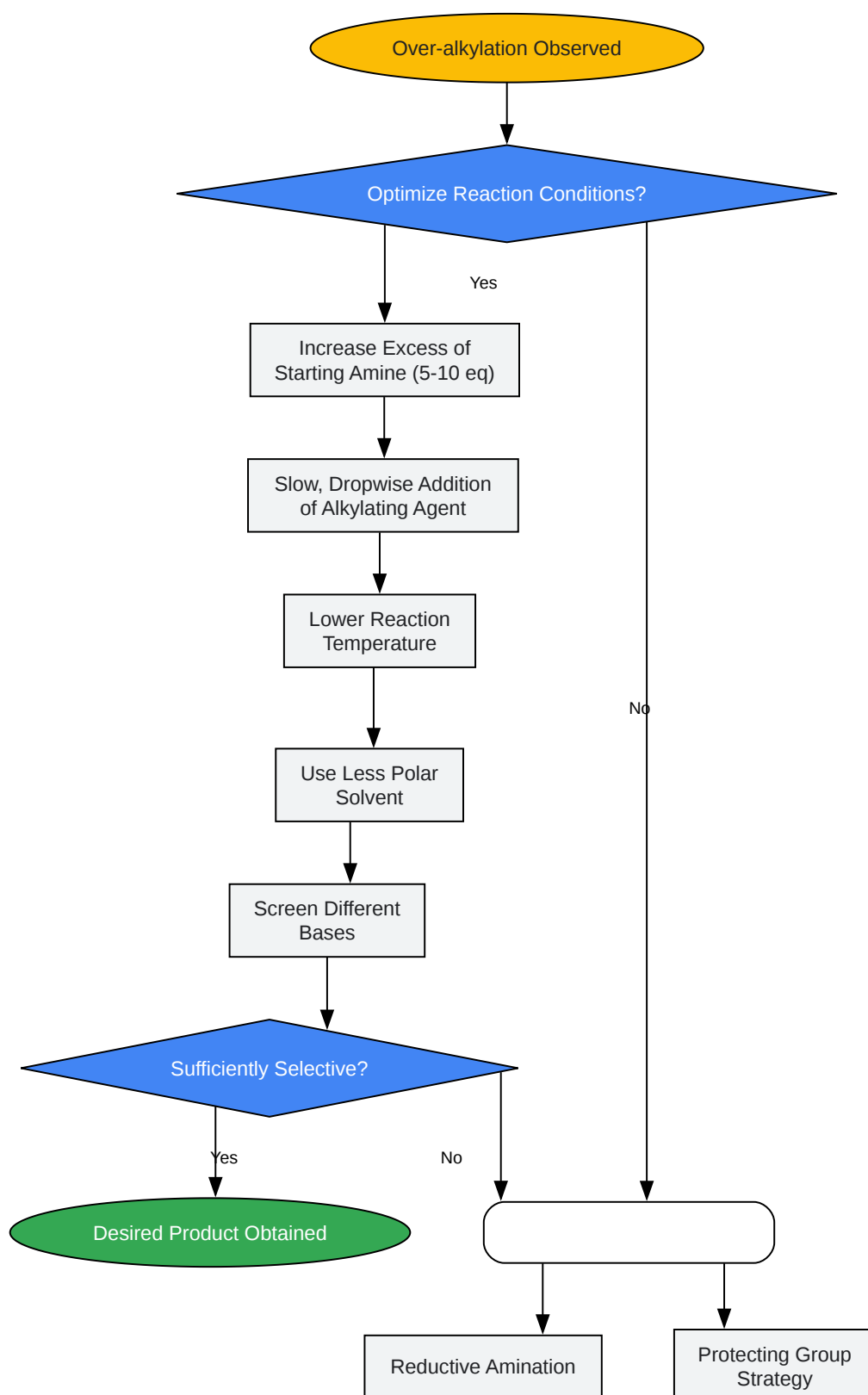

[Click to download full resolution via product page](#)

Caption: Troubleshooting workflow for over-alkylation.

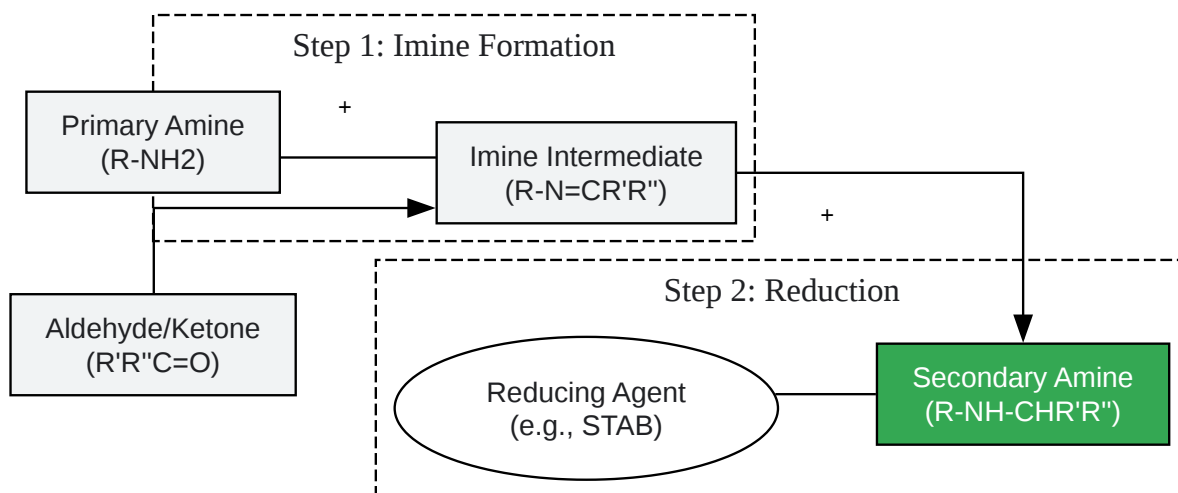

[Click to download full resolution via product page](#)

Need Custom Synthesis?

BenchChem offers custom synthesis for rare earth carbides and specific isotopic labeling.

Email: info@benchchem.com or [Request Quote Online](#).

References

- [1. benchchem.com \[benchchem.com\]](https://www.benchchem.com)
- [2. benchchem.com \[benchchem.com\]](https://www.benchchem.com)
- [3. Avoiding Over-alkylation - Wordpress \[reagents.acsgcipr.org\]](https://reagents.acsgcipr.org)
- [4. pubs.acs.org \[pubs.acs.org\]](https://pubs.acs.org)
- [5. Synthesis of Secondary Amines via Self-Limiting Alkylation - PMC \[pmc.ncbi.nlm.nih.gov\]](https://pubmed.ncbi.nlm.nih.gov)
- To cite this document: BenchChem. [Preventing over-alkylation in subsequent reaction steps]. BenchChem, [2026]. [Online PDF]. Available at: [\[https://www.benchchem.com/product/b1283076/docs#preventing-over-alkylation-in-subsequent-reaction-steps\]](https://www.benchchem.com/product/b1283076/docs#preventing-over-alkylation-in-subsequent-reaction-steps)

Disclaimer & Data Validity:

The information provided in this document is for Research Use Only (RUO) and is strictly not intended for diagnostic or therapeutic procedures. While BenchChem strives to provide accurate protocols, we make no warranties, express or implied, regarding the fitness of this product for every specific experimental setup.

Technical Support: The protocols provided are for reference purposes. Unsure if this reagent suits your experiment?

Need Industrial/Bulk Grade? [Request Custom Synthesis Quote](#)

BenchChem

Our mission is to be the trusted global source of essential and advanced chemicals, empowering scientists and researchers to drive progress in science and industry.

Contact

Address: 3281 E Guasti Rd
Ontario, CA 91761, United States
Phone: (601) 213-4426
Email: info@benchchem.com

[Contact our Ph.D. Support Team for a compatibility check](#)