

# Technical Support Center: Synthesis of Piperidine Butanoic Acid

**Author:** BenchChem Technical Support Team. **Date:** May 2026

## Compound of Interest

Compound Name:	4-(Piperidin-1-yl)butanoic acid hydrochloride
CAS No.:	5463-76-3
Cat. No.:	B1282406

[Get Quote](#)

Welcome to the Technical Support Center. This guide is designed for researchers, scientists, and drug development professionals to address common challenges and side reactions encountered during the synthesis of piperidine butanoic acid and its derivatives. We will explore the causality behind common issues and provide robust, field-proven troubleshooting strategies.

## Part 1: Frequently Asked Questions (FAQs)

This section addresses high-level, common queries that arise during the synthesis of piperidine-based compounds.

Q1: What are the principal synthetic strategies for preparing a piperidine butanoic acid scaffold?

There are two predominant routes for constructing this scaffold:

- **N-Alkylation of a Piperidine Ring:** This is a convergent approach where a pre-existing piperidine core is functionalized with a four-carbon acid or ester chain. The most common

method involves reacting piperidine (or a substituted derivative) with an alkyl halide, such as ethyl 4-bromobutanoate, typically in the presence of a mild base.

- **Reduction of a Pyridine Precursor:** This method involves the hydrogenation of a pyridine ring that already bears the butanoic acid side chain. This is often achieved through catalytic hydrogenation using catalysts like Platinum(IV) oxide (PtO<sub>2</sub>) or Rhodium on carbon (Rh/C) under a hydrogen atmosphere.[1]

Q2: My purified piperidine butanoic acid product is a pale yellow liquid/solid. What causes this discoloration?

A yellow tint in piperidine derivatives is almost always indicative of oxidation.[2] Tertiary amines, and to a lesser extent secondary amines, can be susceptible to oxidation over time, forming N-oxide species or other colored degradation products, especially when exposed to air and light. For most applications, this minor impurity may not be problematic, but for high-purity needs, purification via distillation or column chromatography is recommended.[2][3] Storing the final compound under an inert atmosphere (Nitrogen or Argon) can prevent recurrence.[2]

Q3: During my N-alkylation reaction or workup, an insoluble white solid precipitated. What is it likely to be?

This is a very common observation and typically points to one of two possibilities:

- **Quaternary Ammonium Salt:** This is a common byproduct of N-alkylation. The desired tertiary amine product can react again with the alkylating agent, forming a tetra-alkylated, positively charged quaternary ammonium salt.[4] These salts are often poorly soluble in common organic solvents like acetonitrile or ether, causing them to precipitate.
- **Piperidinium Salt:** If you are using a 4-halobutanoic acid instead of its ester, a simple acid-base reaction will occur. The basic piperidine nitrogen will deprotonate the carboxylic acid, forming a piperidinium carboxylate salt. This salt is often insoluble in non-polar organic solvents. This is a critical reason why the ester form of the butanoic acid chain is almost always used for N-alkylation.

## Part 2: Troubleshooting Guide: Common Side Reactions & Solutions

This section provides a detailed, issue-oriented guide to specific problems encountered in the primary synthetic routes.

## Issue 1: Low Yield and Byproduct Formation in N-Alkylation Route

**Symptom:** Your reaction to alkylate piperidine with a 4-halobutanoate ester shows significant unreacted starting material and/or the appearance of a new, less polar spot on TLC or a higher molecular weight peak in LC-MS.

- **Mechanistic Explanation:** The N-alkylated piperidine product is a tertiary amine. In many cases, this tertiary amine is more nucleophilic than the starting secondary amine (piperidine). Consequently, it can compete with the starting material for the alkylating agent (e.g., ethyl 4-bromobutanoate), leading to the formation of a quaternary ammonium salt. This side reaction consumes both the desired product and the alkylating agent, reducing the overall yield.[4]
- **Solutions & Strategies:**
  - **Control Stoichiometry:** Use a slight excess of the piperidine nucleophile (e.g., 1.2-1.5 equivalents) relative to the alkylating agent. This ensures the alkylating agent is consumed before significant over-alkylation of the product can occur.
  - **Slow Addition:** Add the alkylating agent slowly to the reaction mixture, ideally via a syringe pump.[4] This maintains a low instantaneous concentration of the electrophile, favoring reaction with the more abundant starting amine.
  - **Use a Hindered Base:** Employing a non-nucleophilic, hindered base like N,N-diisopropylethylamine (Hünig's base) can scavenge the HBr byproduct without competing in the alkylation.[4] Standard bases like  $K_2CO_3$  are also effective.[4]
- **Mechanistic Explanation:** The 4-halobutanoate is a primary alkyl halide. While typically favoring  $S_N2$  substitution, if a strong or sterically hindered base is used, a competing  $E2$  elimination reaction can occur, leading to the formation of ethyl but-3-enoate or cyclobutanecarboxylate derivatives.
- **Solutions & Strategies:**

- Choice of Base: Avoid strong, hindered bases like LDA or t-butoxide. Use milder inorganic bases such as potassium carbonate ( $K_2CO_3$ ) or cesium carbonate ( $Cs_2CO_3$ ), which are sufficient to neutralize the acid formed during the reaction but are not strong enough to promote significant elimination.
- Temperature Control: Keep the reaction temperature as low as reasonably possible (e.g., room temperature to  $50^\circ C$ ) to favor the  $S_N2$  pathway, as elimination reactions often have a higher activation energy.

### Diagram: Competing N-Alkylation Pathways

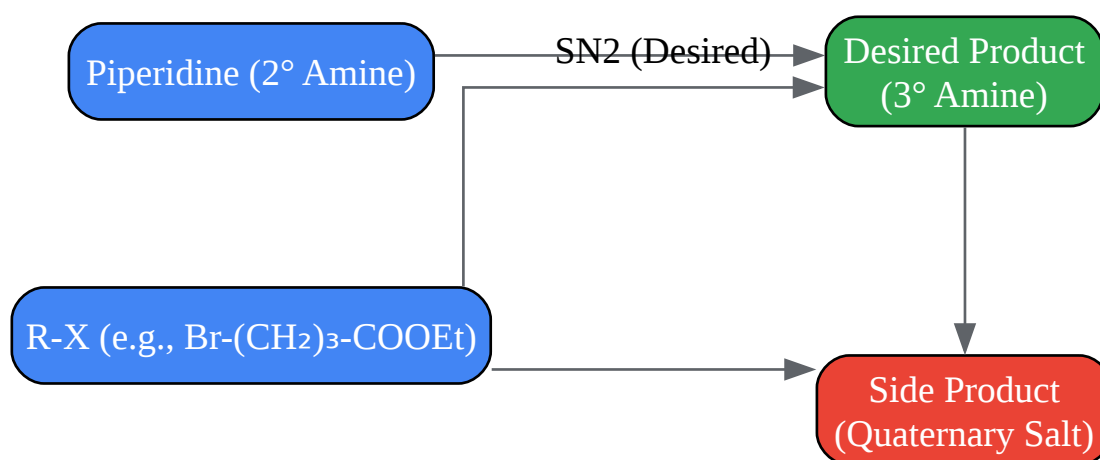

[Click to download full resolution via product page](#)

Caption: Competing  $S_N2$  reactions during N-alkylation of piperidine.

## Issue 2: Incomplete Reduction or Side Products in Pyridine Reduction Route

Symptom: Catalytic hydrogenation of a pyridine-butanoic acid derivative stalls, leaving significant starting material, or generates unexpected byproducts.

- Mechanistic Explanation: The aromatic pyridine ring is exceptionally stable, and its reduction requires breaking this aromaticity. The reaction can sometimes stop at partially hydrogenated intermediates (dihydropyridines or tetrahydropyridines) if the reaction conditions are not sufficiently forcing or if the catalyst becomes deactivated.
- Solutions & Strategies:

- Catalyst Choice & Loading: Use a highly active catalyst like PtO<sub>2</sub> (Adams' catalyst) or a rhodium-based catalyst.[1] If the reaction stalls, consider increasing the catalyst loading (e.g., from 1 mol% to 5 mol%).
- Reaction Conditions: Increase hydrogen pressure (typically 50 psi to 500 psi) and reaction time. Acetic acid is often used as a solvent as the resulting pyridinium salt is more readily reduced.[5]
- Purity of Materials: Ensure the pyridine starting material and solvent are free from catalyst poisons like sulfur or thiol compounds.
- Mechanistic Explanation: Under harsh hydrogenation conditions (high temperature, high pressure, highly active catalyst), the C-N bonds within the newly formed piperidine ring can be cleaved. This ring-opening side reaction leads to the formation of linear amines (e.g., substituted pentylamines), which reduces the yield of the desired cyclic product.[1]
- Solutions & Strategies:
  - Optimize Conditions: Start with milder conditions (lower temperature, lower pressure) and gradually increase them while monitoring the reaction. Rhodium-based catalysts are often reported to be more selective and less prone to causing C-N bond cleavage compared to palladium.[1]
  - Monitor Reaction Progress: Use techniques like GC-MS or <sup>1</sup>H NMR on aliquots to track the disappearance of the starting material and the appearance of the product. Stop the reaction as soon as the starting material is consumed to prevent over-reduction of the product.

## Table 1: Troubleshooting Summary for Piperidine Butanoic Acid Synthesis

Problem	Potential Cause	Key Analytical Signature ( <sup>1</sup> H NMR / MS)	Recommended Solution
Insoluble White Precipitate	Over-alkylation	MS: [M+R] <sup>+</sup> peak. NMR: Downfield shift of N-CH <sub>2</sub> protons.	Use excess piperidine; slow addition of alkylating agent.
Low Yield (Alkylation)	Competing Elimination	MS: [M-HBr] peak.	Use a mild base (K <sub>2</sub> CO <sub>3</sub> ); avoid high temperatures.
Incomplete Reaction (Reduction)	Catalyst Deactivation	Starting material remains after prolonged reaction.	Use high-purity reagents; increase catalyst loading.
Ring-Opened Byproducts	Over-reduction	MS: [M+2H] peak corresponding to linear amine.	Use milder conditions; choose a more selective catalyst (e.g., Rh/C).
Difficulty in Purification	Pyridine/Piperidine Azeotrope	Co-elution in GC; difficult separation by distillation.	Purify via selective carbonate salt formation. <sup>[2][3]</sup>

## Part 3: Key Experimental Protocols

### Protocol: Purification of Piperidine from Pyridine Impurity via Carbonate Salt Formation

This protocol is highly effective for removing unreacted pyridine starting material after a reduction reaction, overcoming the challenge of their azeotropic mixture.<sup>[2][3]</sup>

- **Dissolution:** Dissolve the crude reaction mixture (containing the piperidine product and pyridine impurity) in a suitable organic solvent like diethyl ether or toluene (approx. 5-10 volumes).

- Salt Formation: Bubble dry carbon dioxide (CO<sub>2</sub>) gas through the solution at a moderate rate for 30-60 minutes at room temperature. The piperidine, being a stronger base, will react to form piperidine carbamate/carbonate, which is a solid, while the less basic pyridine will remain in solution.[2][6]
- Isolation: Filter the resulting white precipitate (the piperidine salt) and wash it thoroughly with fresh, cold solvent (e.g., diethyl ether) to remove any remaining traces of dissolved pyridine.
- Liberation of Free Base: Suspend the filtered solid in water and add a strong base, such as 50% aqueous NaOH or KOH, until the pH is >12. This will regenerate the free piperidine base, which will often separate as an organic layer.
- Extraction & Drying: Extract the liberated piperidine into a suitable organic solvent (e.g., dichloromethane or diethyl ether). Dry the organic layer over anhydrous sodium sulfate or magnesium sulfate, filter, and concentrate under reduced pressure to yield the purified piperidine derivative.

## Diagram: Troubleshooting Workflow for Low Product Yield

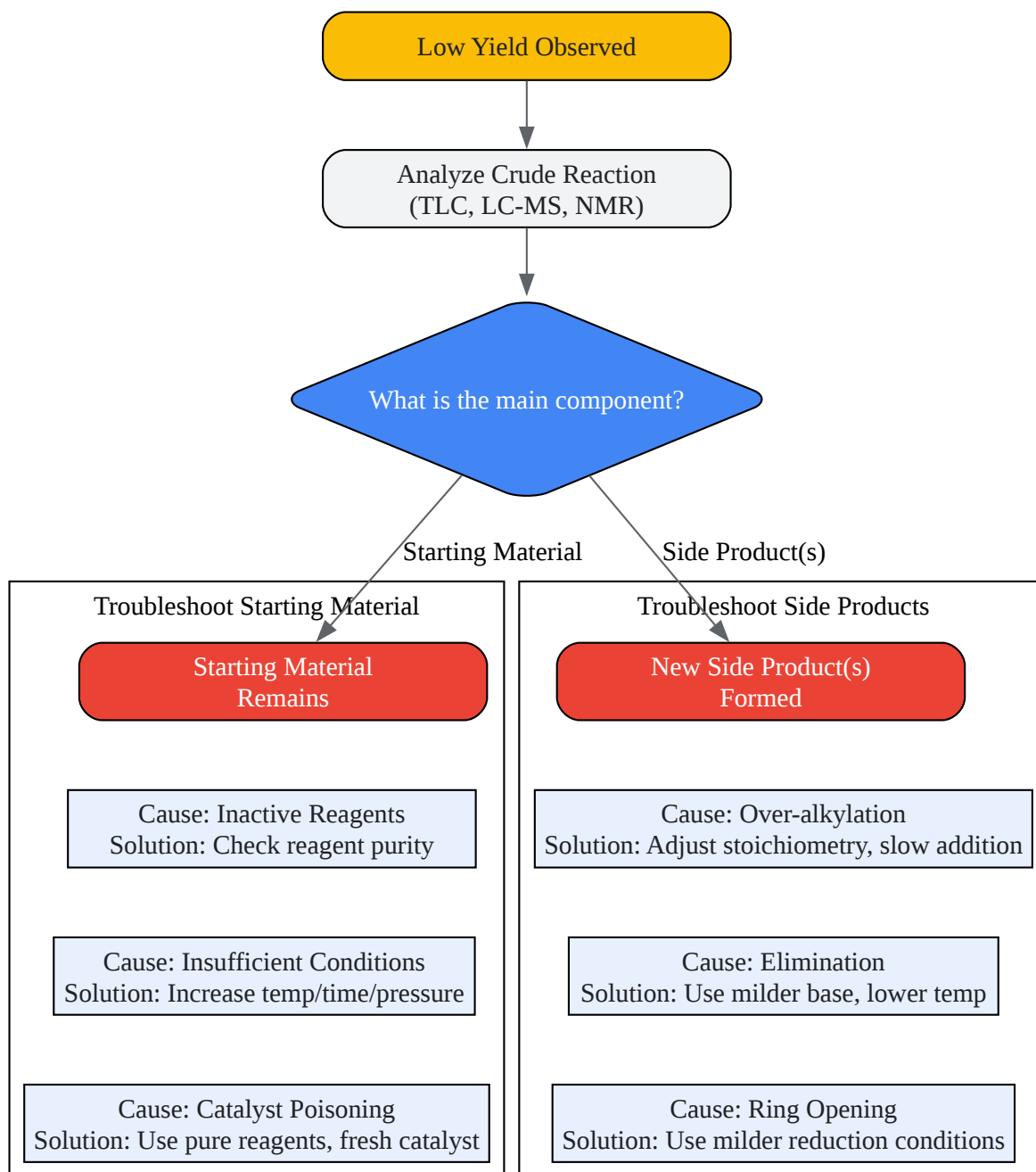

[Click to download full resolution via product page](#)

Caption: A decision-tree workflow for troubleshooting low yields.

## References

- Piperidine Derivatives: Recent Advances in Synthesis and Pharmacological Applications.PMC - PubMed Central.[[Link](#)]
- Process for Preparation of Piperidine Carboxylic Acid.
- Synthesis and Properties of Macrocyclic Butanoic Acid Conjugates as a Promising Delivery Formulation for the Nutrition of Colon.National Institutes of Health (NIH).[[Link](#)]
- Piperidine synthesis.Organic Chemistry Portal.[[Link](#)]
- Synthesis, characterization and antimicrobial activity of piperidine derivatives.ResearchGate.[[Link](#)]
- Piperidine-containing drugs and recently studied analogs - biological activity, mechanism of action and synthetic cascade access to their scaffolds.PubMed.[[Link](#)]
- A kind of purification method of high-purity piperidine.
- Procedure for N-alkylation of Piperidine?ResearchGate.[[Link](#)]
- Synthetic Studies of Alkaloids Containing Pyrrolidine and Piperidine Structural Motifs.PMC - PubMed Central.[[Link](#)]
- THE NOVEL REDUCTION OF PYRIDINE DERIVATIVE5 WITH PiTRODUCXION 3.Nagoya University.[[Link](#)]
- How to remove excess 4-amino piperidine from reaction medium?ResearchGate.[[Link](#)]
- Synthesis of Highly Functionalized Piperidines via One-Pot, Five-Component Reactions in the Presence of Acetic Acid Solvent.ResearchGate.[[Link](#)]

### ***Need Custom Synthesis?***

*BenchChem offers custom synthesis for rare earth carbides and specific isotopic labeling.*

*Email: [info@benchchem.com](mailto:info@benchchem.com) or [Request Quote Online](#).*

## Sources

- [1. pdf.benchchem.com \[pdf.benchchem.com\]](https://pdf.benchchem.com)
- [2. pdf.benchchem.com \[pdf.benchchem.com\]](https://pdf.benchchem.com)
- [3. pdf.benchchem.com \[pdf.benchchem.com\]](https://pdf.benchchem.com)
- [4. researchgate.net \[researchgate.net\]](https://researchgate.net)
- [5. researchgate.net \[researchgate.net\]](https://researchgate.net)
- [6. CN101602748B - A kind of purification method of high-purity piperidine - Google Patents \[patents.google.com\]](https://patents.google.com)
- To cite this document: BenchChem. [Technical Support Center: Synthesis of Piperidine Butanoic Acid]. BenchChem, [2026]. [Online PDF]. Available at: [\[https://www.benchchem.com/product/b1282406/docs#technical-support-center-synthesis-of-piperidine-butanoic-acid\]](https://www.benchchem.com/product/b1282406/docs#technical-support-center-synthesis-of-piperidine-butanoic-acid)

---

### Disclaimer & Data Validity:

The information provided in this document is for Research Use Only (RUO) and is strictly not intended for diagnostic or therapeutic procedures. While BenchChem strives to provide accurate protocols, we make no warranties, express or implied, regarding the fitness of this product for every specific experimental setup.

**Technical Support:** The protocols provided are for reference purposes. Unsure if this reagent suits your experiment?

**Need Industrial/Bulk Grade?** [Request Custom Synthesis Quote](#)

## BenchChem

Our mission is to be the trusted global source of essential and advanced chemicals, empowering scientists and researchers to drive progress in science and industry.

### Contact

Address: 3281 E Guasti Rd  
Ontario, CA 91761, United States  
Phone: (601) 213-4426  
Email: [info@benchchem.com](mailto:info@benchchem.com)

Contact our Ph.D. Support Team for a compatibility check