

# Technical Support Center: Optimizing the Synthesis of 3,4-Dimethoxybenzoic Anhydride

**Author:** BenchChem Technical Support Team. **Date:** May 2026

## Compound of Interest

Compound Name: 3,4-Dimethoxybenzoic anhydride

CAS No.: 24824-54-2

Cat. No.: B1282939

[Get Quote](#)

This guide serves as a comprehensive technical resource for researchers, chemists, and process development professionals engaged in the synthesis of **3,4-Dimethoxybenzoic Anhydride**. Our objective is to provide not just procedural steps, but the underlying chemical logic to empower users to troubleshoot and optimize their reaction conditions effectively. We will explore common synthetic routes, address frequently encountered challenges, and offer field-proven solutions to streamline your workflow and enhance yield and purity.

## Section 1: Frequently Asked Questions (FAQs)

This section addresses foundational questions regarding the synthesis and handling of **3,4-Dimethoxybenzoic Anhydride**.

Q1: What is **3,4-Dimethoxybenzoic Anhydride** and what are its primary applications?

**3,4-Dimethoxybenzoic Anhydride** (also known as Veratric Anhydride) is the symmetrical anhydride of 3,4-Dimethoxybenzoic acid (Veratric acid)[1]. It serves as a reactive acylating agent in organic synthesis. Its primary utility lies in introducing the 3,4-dimethoxybenzoyl group into molecules, a common structural motif in natural products and pharmaceutical compounds.

It is often preferred over the corresponding acid chloride as it produces the non-corrosive and easily removed 3,4-dimethoxybenzoic acid as a byproduct instead of HCl.

Q2: What are the most common laboratory methods for preparing **3,4-Dimethoxybenzoic Anhydride**?

The synthesis of aromatic anhydrides typically involves the dehydration or coupling of the corresponding carboxylic acid. Common methods include:

- Reaction with Acetic Anhydride: Heating the carboxylic acid with acetic anhydride, often with a catalytic amount of acid (like phosphoric acid), can drive the formation of the desired anhydride.[2]
- Activation with Thionyl Chloride or Oxalyl Chloride: A two-step process where the carboxylic acid is first converted to its highly reactive acid chloride. The acid chloride is then reacted with the sodium salt of the carboxylic acid (or the acid itself in the presence of a base like pyridine) to form the anhydride.[3][4][5]
- Using Carbodiimides: Reagents like dicyclohexylcarbodiimide (DCC) can be used to directly couple two molecules of the carboxylic acid, although this is more common for amide bond formation.[6]
- Phosphorus-based Reagents: Systems involving triphenylphosphine (PPh<sub>3</sub>) and an activator like trichloroisocyanuric acid (TCCA) can convert carboxylic acids to anhydrides under mild conditions.[7][8]

Q3: What are the critical safety precautions when working with dehydrating/activating agents?

Many reagents used for anhydride synthesis are hazardous. Always perform a thorough risk assessment before starting any experiment.[2]

- Thionyl Chloride & Oxalyl Chloride: These are corrosive, toxic, and react violently with water to release HCl and SO<sub>2</sub> (for thionyl chloride) or HCl, CO, and CO<sub>2</sub> (for oxalyl chloride). All manipulations must be performed in a certified chemical fume hood with appropriate personal protective equipment (gloves, safety glasses, lab coat).

- Acetic Anhydride: It is corrosive and a lachrymator. Handle in a well-ventilated area or fume hood.
- Pyridine: It is flammable, toxic, and has a strong, unpleasant odor. Work exclusively in a fume hood.
- Anhydrous Conditions: Many of these reactions are highly sensitive to moisture. Ensure all glassware is oven- or flame-dried and reactions are run under an inert atmosphere (e.g., Nitrogen or Argon) to prevent reagent quenching and product hydrolysis.[9]

Q4: How can I reliably confirm the formation and purity of my **3,4-Dimethoxybenzoic Anhydride** product?

A combination of spectroscopic and chromatographic techniques is recommended:

- Infrared (IR) Spectroscopy: This is a primary tool for confirmation. Look for the disappearance of the broad O-H stretch from the carboxylic acid starting material (typically  $\sim 2500\text{-}3300\text{ cm}^{-1}$ ) and the appearance of two characteristic anhydride carbonyl (C=O) stretches, usually around  $1810\text{-}1830\text{ cm}^{-1}$  and  $1740\text{-}1760\text{ cm}^{-1}$ .
- Nuclear Magnetic Resonance (NMR) Spectroscopy:  $^1\text{H}$  NMR will show subtle shifts in the aromatic and methoxy proton signals compared to the starting acid. The acidic proton from the COOH group ( $\sim 10\text{-}12\text{ ppm}$ ) will disappear completely in the pure product.
- Thin-Layer Chromatography (TLC): TLC is excellent for monitoring reaction progress. The anhydride product will typically have a higher  $R_f$  value than the more polar carboxylic acid starting material.
- Mass Spectrometry (MS): This can confirm the molecular weight of the final product.[10]

## Section 2: Troubleshooting Guide

Even with established protocols, challenges can arise. This guide provides a systematic approach to identifying and solving common problems.

### Problem 1: Low or No Product Yield

Potential Cause	Diagnostic Check	Recommended Solution
Moisture Contamination	Re-examine drying procedures for glassware, solvents, and reagents.	Oven-dry all glassware immediately before use. Use freshly distilled or commercially available anhydrous solvents. Ensure the reaction is maintained under a dry, inert atmosphere (N <sub>2</sub> or Ar).[9]
Ineffective Dehydrating/Activating Agent	Check the age and storage conditions of reagents like thionyl chloride, acetic anhydride, or PPh <sub>3</sub> .	Use a freshly opened bottle or a recently purified/distilled reagent. Older reagents can decompose upon storage, especially if exposed to atmospheric moisture.
Sub-optimal Reaction Temperature	Review the literature for the specific method used. Was the temperature too low for the reaction to proceed or too high, causing decomposition?	For methods involving heating (e.g., with acetic anhydride), ensure the temperature is maintained consistently. For highly reactive agents (e.g., oxalyl chloride), reactions are often run at 0 °C or room temperature to prevent side reactions.[2]
Incorrect Stoichiometry	Double-check calculations for all reagents, especially when using multi-step procedures (e.g., acid chloride formation then coupling).	Carefully recalculate molar equivalents. For reactions requiring a base like pyridine, ensure the correct amount is used to scavenge HCl produced.[5]

## Problem 2: Product is Contaminated with Starting Material

Potential Cause	Diagnostic Check	Recommended Solution
Incomplete Reaction	Monitor the reaction by TLC until the starting material spot is completely consumed.	Increase the reaction time. If the reaction has stalled, consider a modest increase in temperature or the addition of a small, fresh portion of the activating/dehydrating agent.
Premature Workup	Review the workup procedure. Was the product exposed to water before all activating agents were quenched or removed?	Ensure the workup is performed under anhydrous conditions until the reactive species are neutralized.
Hydrolysis During Purification	The product is stable but can hydrolyze if exposed to water or silica gel for extended periods.	Minimize contact with water during workup. For chromatography, use a less polar solvent system and run the column quickly. Recrystallization from a non-protic solvent (e.g., toluene/heptane) is often a better purification method. <sup>[2][9]</sup>

## Problem 3: Formation of Unwanted Byproducts

Potential Cause	Diagnostic Check	Recommended Solution
Side reaction with solvent	Analyze crude product by NMR or MS to identify byproduct structures.	Choose an inert solvent. For example, when using thionyl chloride, solvents like toluene or dichloromethane are preferred over ethers, which can be cleaved under acidic conditions.[11]
Reaction Temperature Too High	High temperatures can lead to decomposition or polymerization, especially with activated intermediates.	Maintain the recommended reaction temperature. If the reaction is highly exothermic, add reagents slowly and use an ice bath for cooling.[5]
Mixed Anhydride Formation (with Acetic Anhydride)	If using acetic anhydride, the formation of a mixed 3,4-dimethoxybenzoic acetic anhydride is possible.	Use a sufficient excess of acetic anhydride and ensure adequate heating to drive the equilibrium towards the desired symmetric anhydride. Distilling off the acetic acid formed is crucial.[2]

## Troubleshooting Workflow Diagram

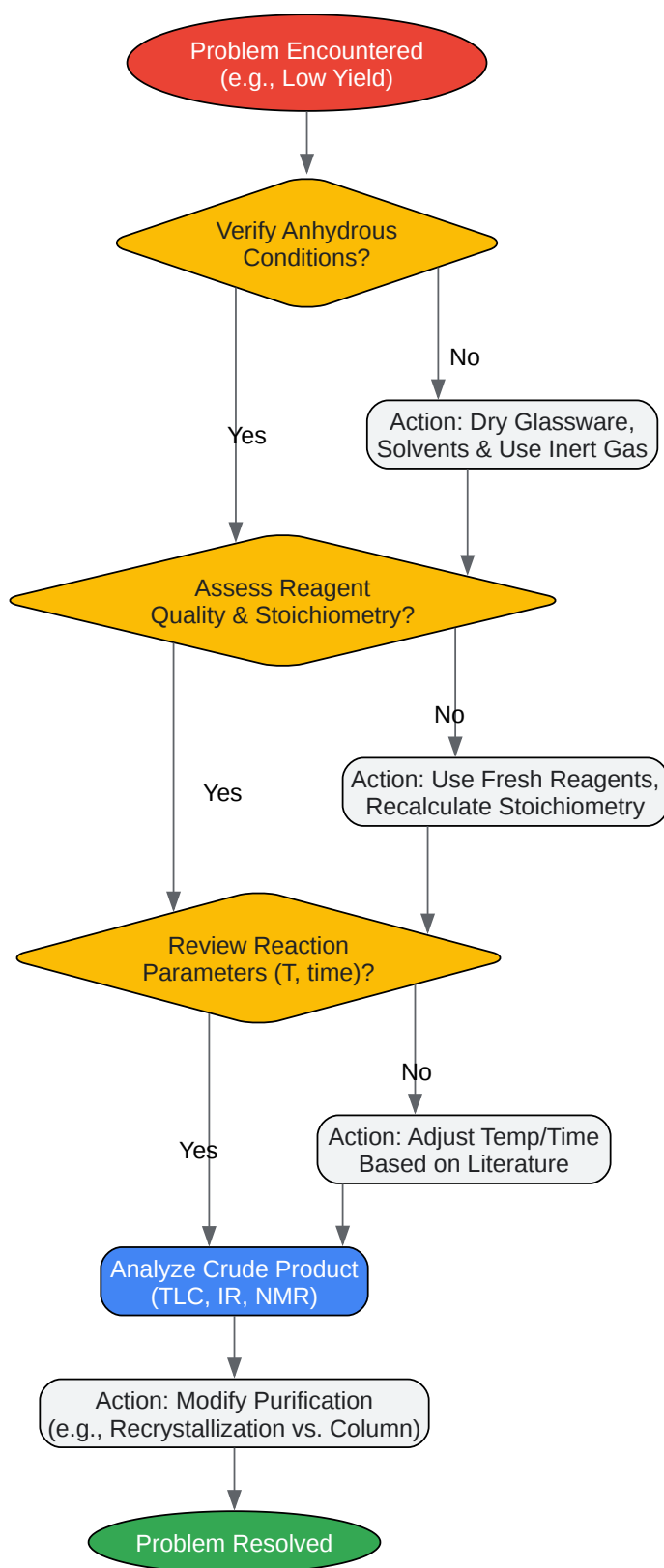

[Click to download full resolution via product page](#)

Caption: A systematic workflow for troubleshooting common issues in anhydride synthesis.

## Section 3: Experimental Protocols

The following protocols are adapted from established methods for aromatic anhydride synthesis and are tailored for 3,4-Dimethoxybenzoic acid.

### Protocol A: Synthesis using Acetic Anhydride

This method is based on the classic procedure for benzoic anhydride and is suitable for larger-scale preparations.[2] The principle is an equilibrium-driven reaction where the volatile acetic acid byproduct is removed by distillation.

Step-by-Step Methodology:

- **Setup:** In a round-bottom flask equipped with a short fractionating column, a distillation head, and a magnetic stirrer, add 3,4-Dimethoxybenzoic acid (1.0 eq).
- **Reagents:** Add acetic anhydride (1.5 - 2.0 eq) and a catalytic amount of 85% phosphoric acid (1-2 drops).
- **Reaction:** Heat the mixture gently in an oil bath. The goal is to slowly distill off the acetic acid that is formed. The temperature at the head of the column should be maintained at or below the boiling point of acetic acid (~118 °C) to avoid distilling the acetic anhydride.
- **Monitoring:** The reaction can be monitored by periodically taking a small aliquot, quenching it carefully, and analyzing by TLC to observe the disappearance of the starting acid.
- **Workup:** Once the reaction is complete (typically several hours), allow the mixture to cool. The excess acetic anhydride can be removed by distillation under reduced pressure.
- **Purification:** The crude **3,4-Dimethoxybenzoic anhydride**, which is a solid, can be purified by recrystallization. A suitable solvent system is Toluene/Heptane. Dissolve the crude solid in a minimal amount of hot toluene and add heptane until the solution becomes cloudy. Allow to cool slowly to form crystals, which are then collected by vacuum filtration.

### Protocol B: Synthesis via the Acid Chloride

This is a higher-yielding, two-step method that proceeds under milder temperature conditions but requires handling more hazardous reagents.[5]

### Step-by-Step Methodology:

- Step 1: Formation of 3,4-Dimethoxybenzoyl Chloride
  - Setup: In a flame-dried, three-neck flask under an N<sub>2</sub> atmosphere, suspend 3,4-Dimethoxybenzoic acid (1.0 eq) in an anhydrous solvent like toluene or CH<sub>2</sub>Cl<sub>2</sub>.
  - Reagent Addition: Add thionyl chloride (SOCl<sub>2</sub>, ~1.5 eq) dropwise at room temperature. A catalytic amount of DMF can accelerate the reaction.
  - Reaction: Stir the mixture at room temperature or with gentle heating (e.g., 50 °C) until the evolution of gas (HCl and SO<sub>2</sub>) ceases and the solid dissolves completely.
  - Isolation: Remove the excess SOCl<sub>2</sub> and solvent under reduced pressure to obtain the crude 3,4-Dimethoxybenzoyl chloride, which can be used directly in the next step.
- Step 2: Coupling to form the Anhydride
  - Setup: In a separate flame-dried flask under N<sub>2</sub>, dissolve 3,4-Dimethoxybenzoic acid (1.0 eq) in anhydrous pyridine (or a less odorous base like triethylamine in a solvent like CH<sub>2</sub>Cl<sub>2</sub>).
  - Reagent Addition: Cool the solution in an ice bath (0 °C). Add a solution of the crude 3,4-Dimethoxybenzoyl chloride (1.0 eq) in a minimal amount of anhydrous CH<sub>2</sub>Cl<sub>2</sub> dropwise with vigorous stirring. A precipitate of pyridinium hydrochloride will form.
  - Reaction: Allow the reaction to stir at 0 °C for 30 minutes and then warm to room temperature for 1-2 hours.
  - Workup: Pour the reaction mixture into ice-cold dilute HCl to neutralize the excess pyridine and dissolve the hydrochloride salt. The product will precipitate out or can be extracted with an organic solvent like ethyl acetate.
  - Purification: Wash the organic layer with water, saturated NaHCO<sub>3</sub> solution, and brine. Dry over anhydrous Na<sub>2</sub>SO<sub>4</sub>, filter, and concentrate under reduced pressure. The crude product can be purified by recrystallization as described in Protocol A.

## General Reaction Mechanism

The formation of an anhydride from a carboxylic acid generally involves two key steps: activation of a carboxyl group and nucleophilic attack by a second carboxyl group.

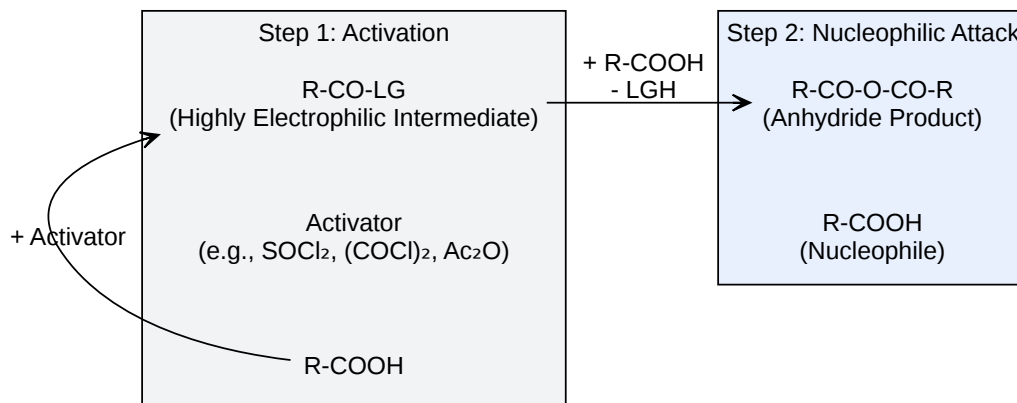

[Click to download full resolution via product page](#)

Caption: General mechanism for anhydride formation.

## References

- Fang, X., et al. (2022). A Facile Synthetic Method for Anhydride from Carboxylic Acid with the Promotion of Triphenylphosphine Oxide and Oxaloyl Chloride. ACS Omega. Available at: [\[Link\]](#)
- Khan Academy. (n.d.). Preparation of acid anhydrides. Available at: [\[Link\]](#)
- American Chemical Society. (2022). A Facile Synthetic Method for Anhydride from Carboxylic Acid with the Promotion of Triphenylphosphine Oxide and Oxaloyl Chloride. ACS Omega. Available at: [\[Link\]](#)
- Google Patents. (1973). Method of making carboxylic acid anhydrides.

- Chemistry Steps. (n.d.). Preparation and Reaction Mechanisms of Carboxylic Anhydrides. Available at: [\[Link\]](#)
- Organic Chemistry Portal. (n.d.). Synthesis of anhydrides. Available at: [\[Link\]](#)
- Google Patents. (n.d.). Synthesis method of 3, 4-dimethoxybenzoic acid methyl ester.
- Organic Syntheses. (n.d.). Benzoic anhydride. Coll. Vol. 1, p.91 (1941); Vol. 2, p.1 (1922). Available at: [\[Link\]](#)
- Cheméo. (n.d.). Chemical Properties of **3,4-Dimethoxybenzoic anhydride**. Available at: [\[Link\]](#)
- ResearchGate. (2002). A Practical Synthesis of 3,4-Dimethoxy-o-toluic Acid. Organic Process Research & Development. Available at: [\[Link\]](#)
- FooDB. (2010). Showing Compound 3,4-Dimethoxybenzoic acid (FDB000222). Available at: [\[Link\]](#)
- Preprints.org. (2024). Modern Analytical Technique for Characterization Organic Compounds. Preprints.org. Available at: [\[Link\]](#)
- LibreTexts Chemistry. (2020). Acid Anhydride Chemistry. Available at: [\[Link\]](#)
- Organic Syntheses. (n.d.). Acid anhydrides. Coll. Vol. 3, p.28 (1955); Vol. 28, p.3 (1948). Available at: [\[Link\]](#)
- Organic Syntheses. (n.d.). 1,4-Dihydrobenzoic acid. Coll. Vol. 5, p.430 (1973); Vol. 42, p.38 (1962). Available at: [\[Link\]](#)
- ResearchGate. (2015). Conversion of benzoic acid to benzoic anhydride using the PPh<sub>3</sub>/TCCA/PhCOOK system under different reaction conditions. Phosphorus, Sulfur, and Silicon and the Related Elements. Available at: [\[Link\]](#)
- ACS Publications. (2000). Fine Chemicals from Lignosulfonates. 2. Synthesis of Veratric Acid from Acetovanillon. Organic Process Research & Development. Available at: [\[Link\]](#)
- Organic Syntheses. (n.d.). N-Formylbenzotriazole. Vol. 90, p.358 (2013). Available at: [\[Link\]](#)

- PubChem. (n.d.). Veratric Acid. Available at: [[Link](#)]
- YouTube. (2019). Making Acid Anhydrides from Carboxylic Acids. jOeCHEM channel. Available at: [[Link](#)]
- ResearchGate. (2006). Synthesis, characterization and thermal behaviour of solid-state compounds of 4-methoxybenzoate with lanthanum (III) and trivalent lighter lanthanides. Eclética Química. Available at: [[Link](#)]

### Need Custom Synthesis?

BenchChem offers custom synthesis for rare earth carbides and specific isotopic labeling.

Email: [info@benchchem.com](mailto:info@benchchem.com) or [Request Quote Online](#).

## Sources

- 1. Veratric Acid | C<sub>9</sub>H<sub>10</sub>O<sub>4</sub> | CID 7121 - PubChem [[pubchem.ncbi.nlm.nih.gov](https://pubchem.ncbi.nlm.nih.gov)]
- 2. Organic Syntheses Procedure [[orgsyn.org](https://orgsyn.org)]
- 3. Khan Academy [[khanacademy.org](https://khanacademy.org)]
- 4. [pubs.acs.org](https://pubs.acs.org) [[pubs.acs.org](https://pubs.acs.org)]
- 5. Organic Syntheses Procedure [[orgsyn.org](https://orgsyn.org)]
- 6. CN114292192A - Synthesis method of 3, 4-dimethoxybenzoic acid methyl ester - Google Patents [[patents.google.com](https://patents.google.com)]
- 7. A Facile Synthetic Method for Anhydride from Carboxylic Acid with the Promotion of Triphenylphosphine Oxide and Oxaloyl Chloride - PMC [[pmc.ncbi.nlm.nih.gov](https://pmc.ncbi.nlm.nih.gov)]
- 8. [researchgate.net](https://researchgate.net) [[researchgate.net](https://researchgate.net)]
- 9. [chem.libretexts.org](https://chem.libretexts.org) [[chem.libretexts.org](https://chem.libretexts.org)]
- 10. [ijpsjournal.com](https://ijpsjournal.com) [[ijpsjournal.com](https://ijpsjournal.com)]
- 11. US3709934A - Method of making carboxylic acid anhydrides - Google Patents [[patents.google.com](https://patents.google.com)]
- To cite this document: BenchChem. [Technical Support Center: Optimizing the Synthesis of 3,4-Dimethoxybenzoic Anhydride]. BenchChem, [2026]. [Online PDF]. Available at:

[<https://www.benchchem.com/product/b1282939/docs#technical-support-center-optimizing-the-synthesis-of-3-4-dimethoxybenzoic-anhydride>]

### Disclaimer & Data Validity:

The information provided in this document is for Research Use Only (RUO) and is strictly not intended for diagnostic or therapeutic procedures. While BenchChem strives to provide accurate protocols, we make no warranties, express or implied, regarding the fitness of this product for every specific experimental setup.

**Technical Support:** The protocols provided are for reference purposes. Unsure if this reagent suits your experiment?

**Need Industrial/Bulk Grade?** [Request Custom Synthesis Quote](#)

## BenchChem

Our mission is to be the trusted global source of essential and advanced chemicals, empowering scientists and researchers to drive progress in science and industry.

### Contact

Address: 3281 E Guasti Rd  
Ontario, CA 91761, United States  
Phone: (601) 213-4426  
Email: [info@benchchem.com](mailto:info@benchchem.com)

[Contact our Ph.D. Support Team for a compatibility check](#)