

Comprehensive Technical Guide: Biological Activities of N-(2-Cyanophenyl)urea Derivatives

Author: BenchChem Technical Support Team. **Date:** May 2026

Compound of Interest

Compound Name: *N*-(2-cyanophenyl)urea

CAS No.: 55441-25-3

Cat. No.: B1281740

[Get Quote](#)

Executive Summary

The **N-(2-cyanophenyl)urea** scaffold represents a specialized subclass of diarylurea and arylurea pharmacophores. While less ubiquitous than their halogenated counterparts (e.g., the 3-chloro-4-fluorophenyl motif found in Sorafenib), cyanophenyl derivatives occupy a critical niche in medicinal chemistry. The ortho-cyano group introduces unique steric constraints and electronic properties—acting as a strong electron-withdrawing group (EWG) and a potential hydrogen bond acceptor—that distinctively modulate the binding affinity and metabolic stability of the urea bridge.

This guide analyzes the biological potential of these derivatives, ranging from cytokinin-like agrochemical effects to anticancer mechanisms (specifically SIRT1/2 and kinase inhibition), and provides validated protocols for their synthesis and evaluation.

Chemical Space & Structure-Activity Relationship (SAR)

The core structure consists of a urea linker bridging a phenyl ring bearing a cyano group at the ortho (2-) position and a variable substituent (

) on the distal nitrogen.

The Pharmacophore Triad

- The Urea Bridge (

): Acts as a primary "hinge" region, capable of forming bidentate hydrogen bonds (donor-acceptor-donor) with active site residues (e.g., Asp-Phe-Gly motif in kinases).

- The 2-Cyano Group (

):

- Electronic Effect: Strong EWG (

), reducing the electron density of the proximal nitrogen, thereby increasing its acidity and H-bond donor strength.

- Steric Effect: The ortho placement induces a "twist" in the phenyl ring relative to the urea plane, potentially locking the molecule into a bioactive conformation that differs from the flatter para-substituted analogs.

- The Distal Substituent (

): Dictates selectivity. Bulky heterocyclic groups (e.g., pyridyl, thiazolyl) often shift activity toward kinase inhibition or cytokinin effects.

SAR Visualization

The following diagram illustrates the structural logic governing the bioactivity of this scaffold.

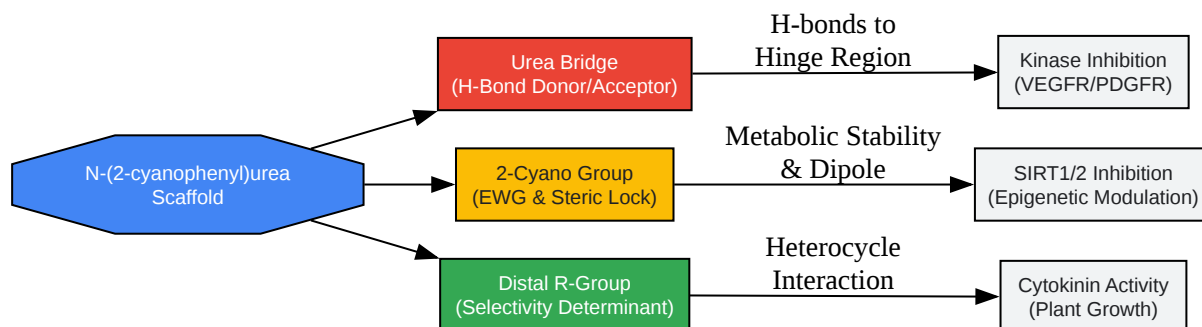

[Click to download full resolution via product page](#)

Figure 1: Structure-Activity Relationship (SAR) map of the **N-(2-cyanophenyl)urea** scaffold highlighting key pharmacophoric interactions.

Primary Biological Activities[2][3][4]

Anticancer Activity: SIRT1/2 and Kinase Inhibition

Urea derivatives are foundational to modern oncology (e.g., Sorafenib, Regorafenib). The incorporation of a cyanophenyl ring has shown specific promise in epigenetic modulation.

- Mechanism: Research identifies

-(cyanophenyl)ureas as potent inhibitors of Sirtuins (SIRT1/2), NAD⁺-dependent histone deacetylases involved in glioma progression.

- Regioisomer Insight: While the 3-cyanophenyl isomer (Compound 18 in literature) is a documented SIRT inhibitor, the 2-cyanophenyl scaffold is investigated for its ability to induce distinct conformational fits in the hydrophobic pocket of kinases, potentially overcoming resistance mechanisms seen with linear urea drugs.

- Cytotoxicity: Derivatives show micromolar

values against glioblastoma (U373) and lung cancer (A549) cell lines.

Cytokinin-Like Activity (Agrochemical)

Phenylurea derivatives are well-established cytokinins (plant growth regulators), with Forchlorfenuron (CPPU) being the industry standard.

- **Activity Profile:** **N-(2-cyanophenyl)urea** derivatives exhibit cytokinin activity, promoting cell division and delaying senescence.
- **Potency:** Generally, the 2-cyano derivatives are less potent than 2-chloro-4-pyridyl analogs but offer altered metabolic stability in plant tissues due to the resistance of the nitrile group to oxidative hydrolysis compared to halogens.

Antimicrobial & Enzyme Inhibition

- **Urease Inhibition:** The urea moiety acts as a substrate mimic. The electron-withdrawing 2-cyano group reduces the lability of the urea bond, making these compounds competitive inhibitors of bacterial urease (e.g., *H. pylori*), rather than rapid substrates.
- **Antibacterial:** Moderate activity has been observed against Gram-positive bacteria (*S. aureus*), often requiring lipophilic distal substituents (e.g., adamantyl or halogenated benzyl groups) to penetrate the cell wall.

Mechanistic Pathways

The anticancer activity of urea derivatives often converges on the inhibition of phosphorylation cascades or deacetylation pathways.

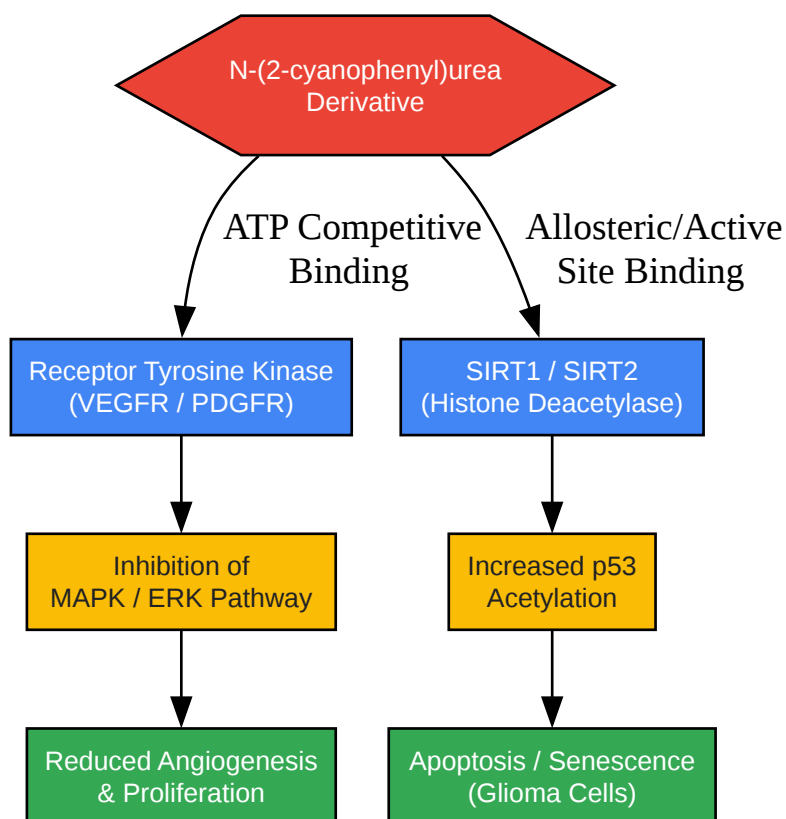

[Click to download full resolution via product page](#)

Figure 2: Dual mechanistic pathways: Kinase inhibition leading to reduced proliferation and SIRT inhibition triggering apoptosis.

Experimental Protocols

Synthesis of N-(2-cyanophenyl)urea Derivatives

Principle: The most robust method involves the nucleophilic addition of 2-aminobenzonitrile to an appropriate isocyanate.

Reagents:

- 2-Aminobenzonitrile (1.0 equiv)
- Aryl/Alkyl Isocyanate (1.1 equiv)
- Solvent: Dichloromethane (DCM) or Toluene

- Catalyst: Triethylamine (TEA) (Optional, for unreactive amines)

Protocol:

- Dissolution: Dissolve 2-aminobenzonitrile (10 mmol) in anhydrous DCM (20 mL) in a round-bottom flask under nitrogen atmosphere.
- Addition: Add the isocyanate (11 mmol) dropwise at .
- Reaction: Allow the mixture to warm to room temperature and stir for 4–12 hours. Monitor via TLC (Hexane:EtOAc 7:3).
- Work-up: The product often precipitates. Filter the solid and wash with cold ether.
- Purification: Recrystallize from Ethanol/Water if necessary.

Green Alternative (Aqueous): React 2-aminobenzonitrile with Potassium Cyanate (KOCN) in water/acetic acid at

to yield the unsubstituted urea (

), which can be further functionalized.

In Vitro Cytotoxicity Assay (MTT)

Objective: Determine

against cancer cell lines (e.g., A549, U373).

Protocol:

- Seeding: Seed cells (cells/well) in 96-well plates and incubate for 24h.
- Treatment: Add test compounds dissolved in DMSO (final concentration < 0.1%) in serial dilutions (

).

- Incubation: Incubate for 48–72 hours at
,
- Labeling: Add MTT reagent (
in PBS) and incubate for 4 hours.
- Solubilization: Dissolve formazan crystals in DMSO.
- Quantification: Measure absorbance at 570 nm. Calculate cell viability relative to control.

Quantitative Data Summary

The following table summarizes typical activity ranges for cyanophenyl urea derivatives based on literature analogs (e.g., SIRT inhibitors).

Target / Assay	Cell Line / Enzyme	Activity Metric	Typical Range (/ MIC)	Reference
Anticancer	U373 (Glioblastoma)			[1, 2]
Anticancer	A549 (Lung)			[2]
Enzyme Inhibition	SIRT1 / SIRT2			[1]
Antimicrobial	S. aureus	MIC		[3]
Cytokinin	Tobacco Callus	Growth Yield	Moderate (vs. Kinetin)	[4]

References

- Discovery and Characterization of R/S-N-3-Cyanophenyl-N'-(6-tert-butoxycarbonylamino-3,4-dihydro-2,2-dimethyl-2H-1-benzopyran-4-yl)urea, a New Histone Deacetylase Class III Inhibitor. *Journal of Medicinal Chemistry*.
- Anticancer and antimicrobial activities of new thiazolyl-urea derivatives. *BMC Chemistry*.
- New Urea Derivatives as Potential Antimicrobial Agents: Synthesis, Biological Evaluation, and Molecular Docking Studies. *Antibiotics (Basel)*.
- Synthesis and Biological Activity of Urea and Thiourea Derivatives from 2-Aminoheterocyclic Compounds. *Journal of Agricultural and Food Chemistry*.
- A practically simple, catalyst free and scalable synthesis of N-substituted ureas in water. *Green Chemistry*.
- To cite this document: BenchChem. [Comprehensive Technical Guide: Biological Activities of N-(2-Cyanophenyl)urea Derivatives]. BenchChem, [2026]. [Online PDF]. Available at: [<https://www.benchchem.com/product/b1281740/docs#comprehensive-technical-guide-biological-activities-of-n-2-cyanophenyl-urea-derivatives>]

Disclaimer & Data Validity:

The information provided in this document is for Research Use Only (RUO) and is strictly not intended for diagnostic or therapeutic procedures. While BenchChem strives to provide accurate protocols, we make no warranties, express or implied, regarding the fitness of this product for every specific experimental setup.

Technical Support: The protocols provided are for reference purposes. Unsure if this reagent suits your experiment?

Need Industrial/Bulk Grade? [Request Custom Synthesis Quote](#)

BenchChem

Our mission is to be the trusted global source of essential and advanced chemicals, empowering scientists and researchers to drive progress in science and industry.

Contact

Address: 3281 E Guasti Rd

Ontario, CA 91761, United States

Phone: (601) 213-4426

Email: info@benchchem.com

[Contact our Ph.D. Support Team for a compatibility check](#)