

Technical Support Center: Optimizing 6-Aminopyridine-3-sulfonyl Chloride Coupling Reactions

Author: BenchChem Technical Support Team. **Date:** May 2026

Compound of Interest

Compound Name:	6-Aminopyridine-3-sulfonyl chloride
CAS No.:	289483-92-7
Cat. No.:	B1280792

[Get Quote](#)

Welcome to the technical support hub for **6-aminopyridine-3-sulfonyl chloride** coupling reactions. This guide is designed for researchers, medicinal chemists, and process development scientists who utilize this versatile building block. The formation of a sulfonamide bond is a cornerstone of modern drug discovery, yet reactions involving bifunctional reagents like **6-aminopyridine-3-sulfonyl chloride** present unique challenges.^[1] This document provides in-depth troubleshooting advice, answers to frequently asked questions, and validated protocols to help you navigate these complexities and improve your reaction yields and reproducibility.

The primary challenge stems from the molecule's dual reactivity: it possesses a highly electrophilic sulfonyl chloride and a nucleophilic aminopyridine moiety. This, combined with the inherent moisture sensitivity of sulfonyl chlorides, creates a landscape ripe for competing side reactions, primarily hydrolysis and self-polymerization.^{[2][3]} This guide is structured to address these issues head-on, providing not just solutions but the chemical reasoning behind them.

Troubleshooting & Optimization Guide

This section is formatted as a series of common problems encountered in the lab. Each problem is followed by a Q&A-style deep dive into potential causes and actionable solutions.

Problem 1: Low to No Product Yield

You've run the reaction, but TLC or LC-MS analysis shows primarily unreacted starting materials or baseline decomposition.

Q1: My primary amine starting material is unconsumed, and I see a new, more polar spot on my TLC/LC-MS. What happened?

A: This is the classic signature of sulfonyl chloride hydrolysis. **6-Aminopyridine-3-sulfonyl chloride** is extremely susceptible to moisture, reacting with trace water to form the corresponding 6-aminopyridine-3-sulfonic acid.^[4] This sulfonic acid is inactive towards coupling and is often the polar baseline material you observe.

- Causality: The sulfur atom in the sulfonyl chloride is highly electrophilic. Water, even in small amounts, can act as a nucleophile, leading to a rapid hydrolysis reaction that is often faster than the desired coupling with a less nucleophilic amine.^{[5][6]}
- Solution Validation:
 - Ensure Anhydrous Conditions: Use oven-dried or flame-dried glassware. Employ anhydrous solvents, preferably from a solvent purification system or a freshly opened bottle stored over molecular sieves. Run the reaction under an inert atmosphere (Nitrogen or Argon).^[7]
 - Verify Reagent Quality: Use a fresh bottle of **6-aminopyridine-3-sulfonyl chloride** or one that has been properly stored in a desiccator. If in doubt, assess its purity before use (see Protocol 2).
 - Temperature Control: Perform the initial addition of the sulfonyl chloride at a low temperature (e.g., 0 °C) to minimize the rate of hydrolysis relative to the amine coupling.

Q2: Both of my starting materials are consumed, but I see no desired product, only a complex mixture of new peaks in the LC-MS.

A: This scenario often points towards self-reaction or reaction with a non-ideal base or solvent.

- Causality: Because **6-aminopyridine-3-sulfonyl chloride** contains both a nucleophile (the amino group) and an electrophile (the sulfonyl chloride), it can react with itself, leading to dimers or oligomers. This is especially prevalent if the concentration is high or if the intended amine partner is significantly less reactive.
- Solution Validation:
 - Order of Addition: The order in which you add reagents is critical. For a standard coupling, slowly add a solution of **6-aminopyridine-3-sulfonyl chloride** to a solution of your target amine and a suitable base. This maintains a low concentration of the sulfonyl chloride, favoring the intermolecular reaction with your target amine over self-reaction.
 - Choice of Base: If you are using a primary or secondary amine as a base (e.g., triethylamine), it can potentially compete with your intended nucleophile.[8] Switch to a non-nucleophilic, sterically hindered base like N,N-diisopropylethylamine (DIPEA) or a purely organic base like 2,6-lutidine or proton sponge. These bases will effectively scavenge the HCl byproduct without participating in the coupling.[9]
 - Solvent Selection: Ensure your solvent is not nucleophilic. Avoid alcohols. Aprotic solvents like Dichloromethane (DCM), Tetrahydrofuran (THF), or Acetonitrile are standard choices.
[1]

Problem 2: Reaction is Sluggish and Stalls Before Completion

The reaction starts, but stalls at ~40-60% conversion, even after extended reaction times.

Q: Why would my reaction stop prematurely?

A: This is typically caused by the deactivation of the amine nucleophile or loss of the active sulfonyl chloride.

- Causality: The coupling reaction generates one equivalent of HCl. If the base is insufficient or too weak to neutralize this acid, the reaction mixture will become acidic. Your amine nucleophile will be protonated to form an ammonium salt, which is no longer nucleophilic, effectively halting the reaction.
- Solution Validation:
 - Base Stoichiometry: Ensure you are using at least 1.1 to 1.5 equivalents of base. If your amine starting material is supplied as a salt (e.g., a hydrochloride salt), you will need an additional equivalent of base to liberate the free amine.
 - Increase Temperature: If the reaction is clean but slow, gently warming the reaction mixture (e.g., to 40 °C) after the initial addition at low temperature can help drive it to completion. Monitor by TLC/LC-MS to ensure this does not induce decomposition.[\[10\]](#)
 - Re-addition of Reagent: If you suspect hydrolysis is the cause of the stall, a carefully controlled second addition of a small amount (0.1-0.2 equiv.) of the sulfonyl chloride may restart the reaction.

Frequently Asked Questions (FAQs)

- Q: What is the best all-around solvent and base combination for this coupling?
 - A: A robust starting point is using DCM as the solvent with 1.5 equivalents of DIPEA as the base at 0 °C to room temperature.[\[1\]](#)[\[7\]](#) Pyridine can also be used as both the base and the solvent, which can be effective for less reactive amines.[\[11\]](#)
- Q: How do I monitor the reaction's progress?
 - A: Thin-Layer Chromatography (TLC) or Liquid Chromatography-Mass Spectrometry (LC-MS) are ideal.[\[12\]](#) For TLC, co-spot your starting materials alongside the reaction mixture to track their consumption and the formation of the new product spot.
- Q: My desired product seems to be degrading during workup or purification. Why?
 - A: The resulting sulfonamide bond can be susceptible to hydrolysis under strongly acidic or basic conditions, especially if there are other activating groups on the molecule. During

workup, use a mild aqueous quench like saturated sodium bicarbonate solution.[7][10]
When performing silica gel chromatography, consider neutralizing the silica by pre-treating it with a solvent mixture containing a small amount of triethylamine (e.g., 1%) to prevent on-column degradation.

- Q: Can I prepare the sulfonyl chloride in situ?
 - A: While possible to generate sulfonyl chlorides from sulfonic acids using reagents like $\text{PCl}_5/\text{POCl}_3$ or SOCl_2 , this is not recommended for this specific substrate in a one-pot coupling reaction.[10][13] These chlorinating agents and the harsh conditions required can lead to numerous side reactions with the aminopyridine moiety. It is far more reliable to use the pre-formed, purified **6-aminopyridine-3-sulfonyl chloride**.

Visualizing the Chemistry

Reaction Mechanism & Key Side Reaction

The following diagram illustrates the desired nucleophilic substitution pathway versus the competing hydrolysis side reaction.

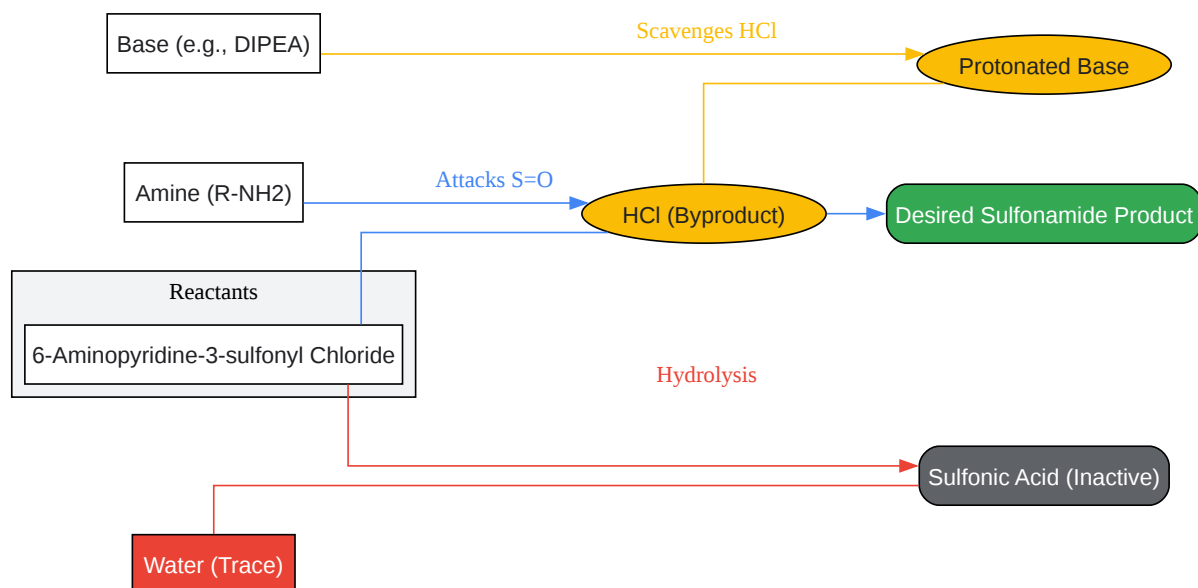

[Click to download full resolution via product page](#)

Caption: Desired coupling vs. hydrolysis side reaction.

Troubleshooting Workflow

This decision tree provides a logical path for diagnosing and solving common issues with the coupling reaction.

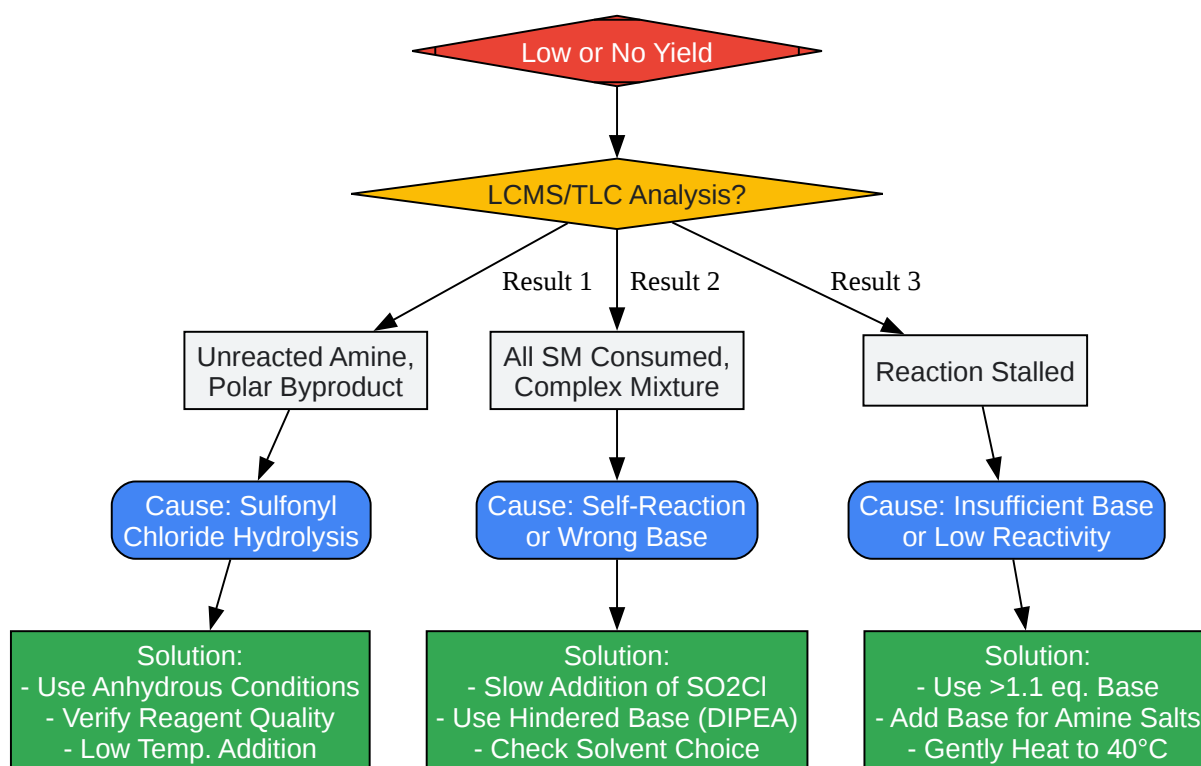

[Click to download full resolution via product page](#)

Caption: A decision tree for troubleshooting poor reaction outcomes.

Experimental Protocols

Protocol 1: Standard Coupling of **6-Aminopyridine-3-sulfonyl Chloride** with a Primary Amine

This protocol provides a reliable starting point for the coupling reaction.

Materials:

- **6-Aminopyridine-3-sulfonyl chloride**
- Primary amine of interest

- N,N-Diisopropylethylamine (DIPEA)
- Anhydrous Dichloromethane (DCM)
- Oven-dried round-bottom flask with a magnetic stir bar
- Inert atmosphere setup (Nitrogen or Argon line)
- Standard workup and purification equipment

Procedure:

- Setup: To the oven-dried flask under an inert atmosphere, add the primary amine (1.0 equiv.).
- Dissolution: Add anhydrous DCM (to make a ~0.1 M solution based on the amine) and stir until fully dissolved.
- Base Addition: Add DIPEA (1.5 equiv.) to the solution.
- Cooling: Cool the reaction mixture to 0 °C using an ice-water bath.
- Sulfonyl Chloride Addition: In a separate dry vial, dissolve **6-aminopyridine-3-sulfonyl chloride** (1.1 equiv.) in a minimal amount of anhydrous DCM.
- Reaction: Add the sulfonyl chloride solution dropwise to the cooled amine solution over 10-15 minutes.
- Monitoring: Allow the reaction to stir at 0 °C for 30 minutes, then warm to room temperature. Monitor the reaction progress by TLC or LC-MS every 1-2 hours until the amine starting material is consumed (typically 4-12 hours).[12]
- Quenching: Once complete, cool the reaction mixture back to 0 °C and slowly quench by adding saturated aqueous sodium bicarbonate solution.[7]
- Workup: Transfer the mixture to a separatory funnel. Separate the layers and extract the aqueous layer twice more with DCM.

- **Washing:** Combine the organic layers and wash sequentially with water and then brine.
- **Drying and Concentration:** Dry the organic layer over anhydrous sodium sulfate (Na_2SO_4), filter, and concentrate under reduced pressure to yield the crude product.
- **Purification:** Purify the crude material by flash column chromatography on silica gel.

Protocol 2: Quality Assessment of **6-Aminopyridine-3-sulfonyl Chloride** via Derivatization

If you suspect your sulfonyl chloride has degraded, this quick test can confirm its reactivity.

Procedure:

- Dissolve a small sample (~10 mg) of the **6-aminopyridine-3-sulfonyl chloride** in 0.5 mL of DCM in a small vial.
- Add a simple, highly nucleophilic amine like piperidine or morpholine (~1.2 equivalents) and a drop of DIPEA.
- Stir at room temperature for 15-20 minutes.
- Analyze a sample of the reaction mixture by LC-MS.
- **Interpretation:** If the sulfonyl chloride is active, you should see near-complete conversion to the corresponding sulfonamide derivative. If you see a large peak corresponding to the starting sulfonyl chloride or the hydrolyzed sulfonic acid, the reagent has likely degraded and should be discarded.

Data Summary Table

The choice of base and solvent can significantly impact reaction outcomes. The following table summarizes general recommendations.

Parameter	Recommended Choice	Rationale & Citation
Solvent	Dichloromethane (DCM), Acetonitrile (MeCN), Tetrahydrofuran (THF)	Aprotic and non-nucleophilic to prevent side reactions.[1]
Base	N,N-Diisopropylethylamine (DIPEA), 2,6-Lutidine, Pyridine	Non-nucleophilic, sterically hindered bases prevent competition with the amine substrate.[9][11]
Base Equiv.	1.1 - 1.5	Ensures complete neutralization of generated HCl, preventing amine protonation.
Temperature	0 °C to Room Temp.	Initial cooling minimizes hydrolysis and exotherm, followed by warming to drive the reaction.[14]
Workup Quench	Saturated aq. NaHCO ₃	Mildly basic quench prevents product hydrolysis during extraction.[7][10]

References

- Organic Chemistry Portal. (n.d.). Synthesis of sulfonamides. Available at: [\[Link\]](#)
- Bakherad, M., et al. (2018). Oxidative reaction of 2-aminopyridine-3-sulfonyl chlorides with tertiary amines. *Research on Chemical Intermediates*, 44, 5315–5323. Available at: [\[Link\]](#)
- Wuhan Green Health Pharmaceutical Technology Co., Ltd. (2022). Method for detecting content of pyridine-3-sulfonyl chloride. CN114713915A.
- Suzhou Huayisheng Biological Medicine Co., Ltd. (2021). Synthesis method of pyridine-3-sulfonyl chloride. CN112830892A.
- Bar-Eli, K., & Gutfreund, H. (2019). Selective Late-Stage Sulfonyl Chloride Formation from Sulfonamides Enabled by Piry-BF₄. *Angewandte Chemie International Edition*, 58(52),

18235-18239. Available at: [\[Link\]](#)

- Singh, S., et al. (2013). Syntheses and Characterization of Some Novel Substituted Pyridosulfonamide Derivatives as Antimicrobial Agents. *Rasayan Journal of Chemistry*, 6(3), 196-200. Available at: [\[Link\]](#)
- OChemPag. (2020). 26.04 Protecting Groups for Amines: Sulfonamides. YouTube. Available at: [\[Link\]](#)
- Reddit user discussion. (2021). Tips and tricks for difficult amide bond formation? r/Chempros. Available at: [\[Link\]](#)
- MacMillan, D. S., et al. (2013). Evaluation of alternative solvents in common amide coupling reactions: replacement of dichloromethane and N,N-dimethylformamide. *Green Chemistry*, 15, 596-600. Available at: [\[Link\]](#)
- Robertson, R. E., & Laughton, P. M. (1969). Solvolysis of a Series of Benzenesulfonyl Chlorides. *Canadian Journal of Chemistry*, 47(21), 4001-4006. Available at: [\[Link\]](#)
- King, J. F., et al. (1984). Mechanisms of Hydrolysis and Related Nucleophilic Displacement Reactions of Alkanesulfonyl Chlorides. *Journal of the American Chemical Society*, 106(12), 3588-3596. Available at: [\[Link\]](#)
- Eze, F. U., et al. (2019). Coupling reaction of benzenesulphonyl chloride with different substituted aromatic amines. *Journal of the Turkish Chemical Society, Section A: Chemistry*, 6(3), 399-408. Available at: [\[Link\]](#)
- ResearchGate. (n.d.). The sulfonamide bond in medically relevant compounds. Available at: [\[Link\]](#)
- Chen, C-Y., et al. (2022). Discovery of N-(6-Methoxypyridin-3-yl)quinoline-2-amine Derivatives for Imaging Aggregated α -Synuclein in Parkinson's Disease with Positron Emission Tomography. *Molecules*, 27(21), 7578. Available at: [\[Link\]](#)
- Takeda Pharmaceutical Co., Ltd. (2016). Pyridine-3-sulfonyl chloride production method. WO2016204096A1.

- Atofina. (2001). Process for preparing sulphonate salts via alkaline hydrolysis of the corresponding sulfonyl chlorides. FR2795723A1.
- Agency for Toxic Substances and Disease Registry. (2003). Analytical Methods. In Toxicological Profile for Pyrethrins and Pyrethroids. Available at: [\[Link\]](#)
- King, J. F., & Hillhouse, J. H. (1983). The mechanism of hydrolysis of 2-hydroxyethanesulfonyl chloride: the intermediacy of 1,2-oxathietane 2,2-dioxide (β -sultone). Canadian Journal of Chemistry, 61(7), 1583-1592. Available at: [\[Link\]](#)
- Kice, J. L., & Kasperek, G. J. (1988). Kinetics and mechanism of hydrolysis of aromatic sulfonyl chlorides in aqueous sulfuric acid solutions. OSTI.GOV. Available at: [\[Link\]](#)

Need Custom Synthesis?

BenchChem offers custom synthesis for rare earth carbides and specific isotopic labeling.

Email: info@benchchem.com or [Request Quote Online](#).

Sources

- [1. Evaluation of alternative solvents in common amide coupling reactions: replacement of dichloromethane and N , N -dimethylformamide - Green Chemistry \(RSC Publishing\)](#)
DOI:10.1039/C2GC36900A [[pubs.rsc.org](#)]
- [2. Method for detecting content of pyridine-3-sulfonyl chloride - Eureka | Patsnap](#)
[[eureka.patsnap.com](#)]
- [3. cdnsciencepub.com](#) [[cdnsciencepub.com](#)]
- [4. WO2016204096A1 - Pyridine-3-sulfonyl chloride production method - Google Patents](#)
[[patents.google.com](#)]
- [5. pubs.acs.org](#) [[pubs.acs.org](#)]
- [6. FR2795723A1 - PROCESS FOR PREPARING SULPHONATE SALTS VIA ALKALINE HYDROLYSIS OF THE CORRESPONDING SULFONYL CHLORIDES - Google Patents](#)
[[patents.google.com](#)]
- [7. benchchem.com](#) [[benchchem.com](#)]
- [8. researchgate.net](#) [[researchgate.net](#)]
- [9. Sulfonamide synthesis by S-N coupling](#) [[organic-chemistry.org](#)]

- [10. Bot Verification \[rasayanjournal.co.in\]](#)
- [11. researchgate.net \[researchgate.net\]](#)
- [12. mdpi.com \[mdpi.com\]](#)
- [13. reddit.com \[reddit.com\]](#)
- [14. CN112830892A - Synthesis method of pyridine-3-sulfonyl chloride - Google Patents \[patents.google.com\]](#)
- To cite this document: BenchChem. [Technical Support Center: Optimizing 6-Aminopyridine-3-sulfonyl Chloride Coupling Reactions]. BenchChem, [2026]. [Online PDF]. Available at: [\[https://www.benchchem.com/product/b1280792/docs#technical-support-center-optimizing-6-aminopyridine-3-sulfonyl-chloride-coupling-reactions\]](https://www.benchchem.com/product/b1280792/docs#technical-support-center-optimizing-6-aminopyridine-3-sulfonyl-chloride-coupling-reactions)

Disclaimer & Data Validity:

The information provided in this document is for Research Use Only (RUO) and is strictly not intended for diagnostic or therapeutic procedures. While BenchChem strives to provide accurate protocols, we make no warranties, express or implied, regarding the fitness of this product for every specific experimental setup.

Technical Support: The protocols provided are for reference purposes. Unsure if this reagent suits your experiment?

Need Industrial/Bulk Grade? [Request Custom Synthesis Quote](#)

BenchChem

Our mission is to be the trusted global source of essential and advanced chemicals, empowering scientists and researchers to drive progress in science and industry.

Contact

Address: 3281 E Guasti Rd
Ontario, CA 91761, United States
Phone: (601) 213-4426
Email: info@benchchem.com

Contact our Ph.D. Support Team for a compatibility check