

Technical Support Center: Navigating Side Reactions in N,N-bis-Boc Deprotection

Author: BenchChem Technical Support Team. **Date:** May 2026

Compound of Interest

Compound Name:	2-(N,N-Bisboc-amino)pyrimidine-5-boronic acid, pinacol ester
CAS No.:	1190423-36-9
Cat. No.:	B1280696

[Get Quote](#)

Welcome to our dedicated technical support guide for researchers, scientists, and drug development professionals encountering challenges with the deprotection of N,N-bis-Boc protected amines. This resource is designed to provide in-depth, field-tested insights and actionable troubleshooting strategies to help you overcome common hurdles and ensure the integrity of your synthetic routes.

The tert-butyloxycarbonyl (Boc) group is a cornerstone of amine protection in modern organic synthesis, prized for its stability and generally mild removal conditions.[1][2] However, the seemingly straightforward acid-catalyzed deprotection of the sterically hindered N,N-bis-Boc moiety can be fraught with complications, leading to yield loss, complex purification challenges, and sometimes, unexpected molecular architectures. This guide moves beyond standard protocols to explore the causality behind these side reactions and equip you with the knowledge to preempt and resolve them.

Frequently Asked Questions (FAQs) & Troubleshooting Guide

This section directly addresses specific issues you may encounter during your experiments in a question-and-answer format.

Issue 1: Incomplete or Sluggish Deprotection

Question: My N,N-bis-Boc deprotection is not going to completion, even with extended reaction times. What factors could be at play, and how can I drive the reaction forward?

Answer: Incomplete deprotection is a common frustration, often stemming from a few key factors:

- **Insufficient Acid Strength or Stoichiometry:** The cleavage of the Boc group is an acid-catalyzed process.^[3] For the removal of two sterically bulky Boc groups, a significant excess of a strong acid is typically required. If you are observing a sluggish reaction, consider the following:
 - **Increase Acid Concentration:** Gradually increase the concentration of trifluoroacetic acid (TFA) in your reaction mixture. Solutions of 50-95% TFA in a solvent like dichloromethane (DCM) are common.^[4] For particularly stubborn substrates, neat TFA may be necessary.
 - **Alternative Strong Acids:** Consider using 4M HCl in dioxane, which can be more effective for certain substrates.^[5]
- **Steric Hindrance:** The steric environment around the N,N-bis-Boc group can significantly impede the approach of the acid, slowing down the reaction rate.^[3] In such cases, more forcing conditions may be required.
- **Reaction Temperature:** While most Boc deprotections are conveniently run at room temperature, increasing the temperature to 40-50°C can sometimes be necessary for less reactive substrates.^[6] However, be aware that higher temperatures can also accelerate side reactions.

Troubleshooting Workflow for Incomplete Deprotection

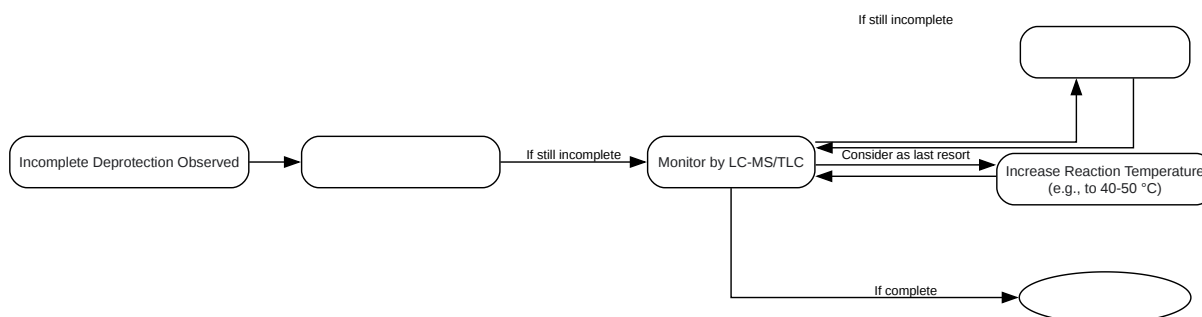

[Click to download full resolution via product page](#)

Caption: A stepwise approach to troubleshooting incomplete N,N-bis-Boc deprotection.

Issue 2: Observation of a +56 Da Adduct in Mass Spectrometry

Question: My LC-MS analysis shows a significant peak with a mass increase of +56 Da compared to my expected product. What is this species, and how can I prevent its formation?

Answer: A mass increase of +56 Da is the hallmark of tert-butylation, a prevalent side reaction during acid-mediated Boc deprotection.[4][7]

Mechanism of tert-Butylation:

The deprotection mechanism proceeds through the formation of a carbamic acid and a highly reactive tert-butyl cation.[8] This cation is a potent electrophile that can be "trapped" by nucleophilic functionalities within your molecule or the solvent, leading to the formation of an unwanted tert-butyl adduct.[3][9]

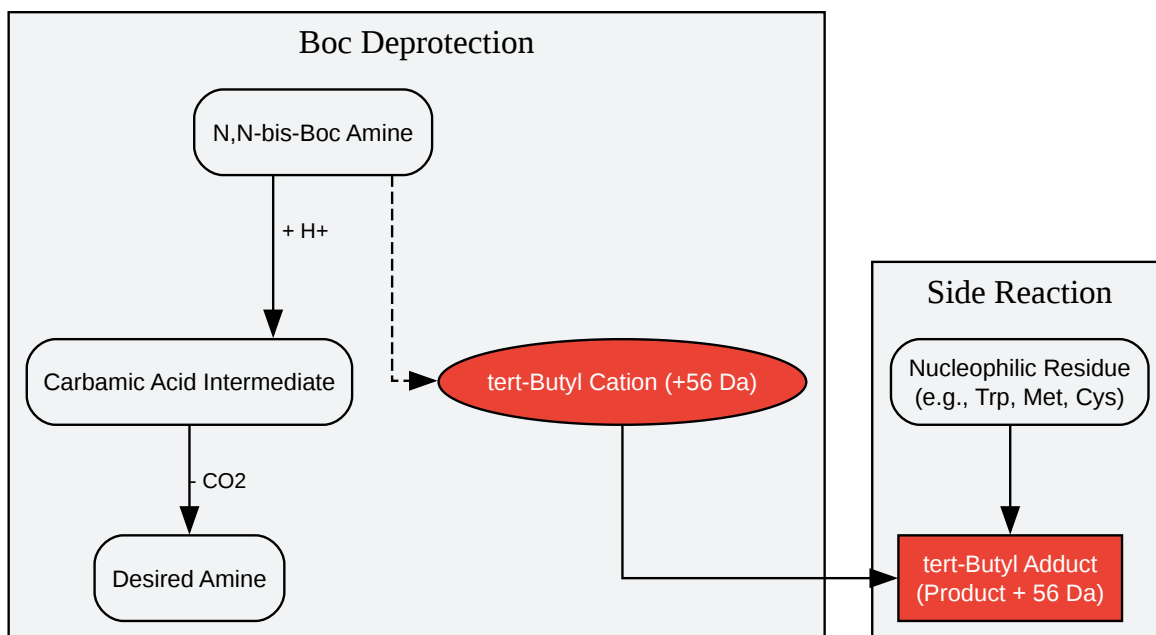

[Click to download full resolution via product page](#)

Caption: The formation of the tert-butyl cation during deprotection and subsequent alkylation of nucleophiles.

Susceptible Functional Groups:

Certain amino acid residues and functional groups are particularly prone to tert-butylation:

Functional Group	Residue/Moiety Example
Indole Ring	Tryptophan (Trp)
Thioether	Methionine (Met)
Thiol	Cysteine (Cys)
Phenolic Ring	Tyrosine (Tyr)
Guanidinium Group	Arginine (Arg)

Prevention Strategies: The Role of Scavengers

The most effective way to mitigate tert-butylation is by introducing "scavengers" into the reaction mixture.[6] These are nucleophilic species that are more reactive towards the tert-butyl cation than your substrate, effectively trapping it before it can cause unwanted alkylation.[3]

Scavenger	Mechanism of Action	Typical Concentration
Triisopropylsilane (TIS)	Reduces the tert-butyl cation to isobutane.	1-5% (v/v)
Thioanisole	Acts as a cation trap through electrophilic aromatic substitution.	1-5% (v/v)
Water	Can act as a scavenger, but may not be sufficient for highly sensitive substrates.	1-5% (v/v)
1,2-Ethanedithiol (EDT)	Particularly effective for protecting Cysteine residues.	1-2.5% (v/v)

Experimental Protocol: Boc Deprotection with Scavengers

- Preparation: Dissolve the N,N-bis-Boc protected substrate in anhydrous DCM under an inert atmosphere.
- Scavenger Addition: Add the chosen scavenger(s) (e.g., 5% TIS, 5% water) to the solution.
- Cooling: Cool the mixture to 0°C in an ice bath.
- TFA Addition: Slowly add trifluoroacetic acid (TFA) to the desired final concentration (e.g., 50-95% v/v).[4]
- Reaction: Stir the reaction at 0°C for 30 minutes, then allow it to warm to room temperature. Monitor the reaction progress by TLC or LC-MS.
- Work-up: Upon completion, concentrate the reaction mixture under reduced pressure. Co-evaporate with toluene or DCM (3x) to remove residual TFA. The crude product can then be purified by precipitation from cold diethyl ether or by chromatography.[4]

Issue 3: Substrate Contains Other Acid-Sensitive Groups

Question: My molecule contains other acid-labile protecting groups (e.g., tert-butyl esters, trityl groups). How can I selectively deprotect the N,N-bis-Boc group?

Answer: Achieving selectivity in the presence of other acid-sensitive functionalities is a significant challenge. While the N,N-bis-Boc group is generally more acid-labile than many other protecting groups, fine-tuning the reaction conditions is critical.

- **Milder Acidic Conditions:** Using weaker acids or more dilute solutions of strong acids can sometimes provide the desired selectivity.^[6] For example, starting with a lower concentration of TFA (e.g., 10-20% in DCM) and carefully monitoring the reaction can allow for the removal of the N,N-bis-Boc group before other groups are cleaved.
- **Lewis Acids:** Certain Lewis acids can offer a different reactivity profile and may provide better selectivity. Reagents like TMSOTf in the presence of 2,6-lutidine can be effective.^[4]
- **Thermal Deprotection:** In some cases, thermal deprotection can be a viable alternative. Heating the substrate in a suitable solvent, such as trifluoroethanol (TFE) or even water, can effect Boc removal without the need for acid.^{[10][11]} This method can be particularly useful for substrates that are highly sensitive to strong acids.

Alternative Deprotection Protocol: TMSOTf/2,6-Lutidine

- **Preparation:** Dissolve the N,N-bis-Boc protected compound in anhydrous DCM under an inert atmosphere.
- **Base Addition:** Add 2,6-lutidine (1.5-2.0 equivalents).
- **Cooling:** Cool the solution to 0°C.
- **TMSOTf Addition:** Add trimethylsilyl trifluoromethanesulfonate (TMSOTf) (1.5-2.0 equivalents) dropwise.
- **Reaction:** Stir at 0°C and monitor by TLC/LC-MS.
- **Quenching and Work-up:** Quench the reaction with methanol. Dilute with an organic solvent and wash with water and saturated aqueous sodium bicarbonate.^[4]

References

- Technical Support Center: Preventing Side Reactions During Boc Deprotection. Benchchem.
- Boc-guanidine deprotection side reactions and how to avoid them. Benchchem.
- BOC Deprotection. Wordpress - ACS GCI Pharmaceutical Roundtable Reagent Guides.
- Technical Support Center: Boc Deprotection with Trifluoroacetic Acid (TFA). Benchchem.
- N-Boc deprotection issues and alternative methods. Benchchem.
- BOC Protection and Deprotection. Hebei Boze Chemical Co., Ltd.
- Boc Protecting Group: N-Boc Protection & Deprotection Mechanism. Total Synthesis.
- Kinetics and Mechanism of N-Boc Cleavage: Evidence of a Second-Order Dependence upon Acid Concentration. ResearchGate.
- BOC Protection and Deprotection. J&K Scientific LLC.
- A Simple and Efficient Green Method for the Deprotection of N-Boc in Various Structurally Diverse Amines under Water-mediated.
- Troubleshooting N-Boc deprotection in the presence of sensitive functional groups. Benchchem.
- Advice on N-boc deprotection in the presence of acid sensitive groups. Reddit. Available at: [\[Link\]](#)
- A Simple and Efficient Green Method for the Deprotection of N-Boc in Various Structurally Diverse Amines under Water-mediated. Semantic Scholar.
- Alternative Methods for Boc Deprotection. Reddit. Available at: [\[Link\]](#)
- Side reactions of Boc deprotection with scavengers. Benchchem.
- Selective Thermal Deprotection of N-Boc Protected Amines in Continuous Flow. ACS Publications. Available at: [\[Link\]](#)
- Amine Protection / Deprotection. Fisher Scientific. Available at: [\[Link\]](#)
- Boc Deprotection Mechanism - TFA. Common Organic Chemistry. Available at: [\[Link\]](#)
- tert-Butyloxycarbonyl protecting group. Wikipedia. Available at: [\[Link\]](#)
- (A) BOC deprotection mechanism with aid of a scavenger. (B) Thermal method for BOC deprotection. ResearchGate. Available at: [\[Link\]](#)

- Green Chemistry Approaches to N-Boc Protection and Deprotection: A Technical Support Center. Benchchem.
- Mild deprotection of the N-tert-butyloxycarbonyl (N-Boc) group using oxalyl chloride. NIH. Available at: [\[Link\]](#)
- Mild deprotection of the N-tert-butyloxycarbonyl (N-Boc) group using oxalyl chloride. RSC Publishing. Available at: [\[Link\]](#)
- Boc-Protected Amino Groups. Organic Chemistry Portal. Available at: [\[Link\]](#)
- Mild deprotection of the N-tert-butyloxycarbonyl (N-Boc) group using oxalyl chloride.
- Deprotection of N-Boc Groups Under Continuous Flow High Temperature Conditions.
- Mild deprotection of the N-tert-butyloxycarbonyl (N-Boc) group using oxalyl chloride.
- What are appropriate scavengers in the t-butyl group deprotection in peptide synthesis?. Available at: [\[Link\]](#)
- Rapid, effective deprotection of tert-butoxycarbonyl (Boc) amino acids and peptides at high temperatures using a thermally stabl. The Royal Society of Chemistry. Available at: [\[Link\]](#)
- TFA Cleavage Strategy for Mitigation of S-tButylated Cys-Peptide Formation in Solid-Phase Peptide Synthesis. ACS Publications. Available at: [\[Link\]](#)
- TLC monitoring of N-Boc-D-proline protection and deprotection reactions. Benchchem.
- Rapid Deprotection of N-Boc Amines by TFA Combined with Freebase Generation Using Basic Ion-Exchange Resins. ResearchGate. Available at: [\[Link\]](#)
- N-tert-Butoxycarbonylation of Structurally Diverse Amines and Sulfamides under Water-Mediated Catalyst-Free Conditions. NIH. Available at: [\[Link\]](#)
- Amine Protection and Deprotection. Master Organic Chemistry. Available at: [\[Link\]](#)
- Deprotection of N-Boc Groups under Continuous-Flow High-Temperature Conditions.

Need Custom Synthesis?

BenchChem offers custom synthesis for rare earth carbides and specific isotopic labeling.

Email: info@benchchem.com or [Request Quote Online](#).

Sources

- [1. N-tert-Butoxycarbonylation of Structurally Diverse Amines and Sulfamides under Water-Mediated Catalyst-Free Conditions - PMC \[pmc.ncbi.nlm.nih.gov\]](#)
- [2. masterorganicchemistry.com \[masterorganicchemistry.com\]](#)
- [3. pdf.benchchem.com \[pdf.benchchem.com\]](#)
- [4. pdf.benchchem.com \[pdf.benchchem.com\]](#)
- [5. pdf.benchchem.com \[pdf.benchchem.com\]](#)
- [6. pdf.benchchem.com \[pdf.benchchem.com\]](#)
- [7. pdf.benchchem.com \[pdf.benchchem.com\]](#)
- [8. Boc Deprotection Mechanism - TFA \[commonorganicchemistry.com\]](#)
- [9. BOC Deprotection - Wordpress \[reagents.acsgcpr.org\]](#)
- [10. pdfs.semanticscholar.org \[pdfs.semanticscholar.org\]](#)
- [11. pubs.acs.org \[pubs.acs.org\]](#)
- To cite this document: BenchChem. [Technical Support Center: Navigating Side Reactions in N,N-bis-Boc Deprotection]. BenchChem, [2026]. [Online PDF]. Available at: [\[https://www.benchchem.com/product/b1280696/docs#technical-support-center-navigating-side-reactions-in-n-n-bis-boc-deprotection\]](https://www.benchchem.com/product/b1280696/docs#technical-support-center-navigating-side-reactions-in-n-n-bis-boc-deprotection)

Disclaimer & Data Validity:

The information provided in this document is for Research Use Only (RUO) and is strictly not intended for diagnostic or therapeutic procedures. While BenchChem strives to provide accurate protocols, we make no warranties, express or implied, regarding the fitness of this product for every specific experimental setup.

Technical Support: The protocols provided are for reference purposes. Unsure if this reagent suits your experiment?

Need Industrial/Bulk Grade? [Request Custom Synthesis Quote](#)

BenchChem

Our mission is to be the trusted global source of essential and advanced chemicals, empowering scientists and researchers to drive progress in science and industry.

Contact

Address: 3281 E Guasti Rd
Ontario, CA 91761, United States
Phone: (601) 213-4426
Email: info@benchchem.com

[Contact our Ph.D. Support Team for a compatibility check](#)