

Technical Deep Dive: Strategic Research Frontiers for Triazole-Based Compounds

Author: BenchChem Technical Support Team. **Date:** May 2026

Compound of Interest

Compound Name: *[3-(1H-1,2,4-Triazol-1-yl)phenyl]methylamine*

CAS No.: 741717-66-8

Cat. No.: B1280476

[Get Quote](#)

Executive Summary: The Privileged Scaffold

In the landscape of modern chemical research, the triazole moiety—specifically the 1,2,3-triazole and 1,2,4-triazole isomers—stands as a "privileged scaffold." Its ubiquity is not accidental but driven by unique physicochemical properties: high dipole moments (approx. 5D), resistance to metabolic degradation, and the ability to function as a rigid bioisostere for amide bonds.

For drug development professionals and material scientists, the triazole ring offers a versatile platform. It serves as a pharmacophore in kinase inhibitors, a stable linker in Proteolysis Targeting Chimeras (PROTACs), and a robust corrosion inhibitor in industrial applications. This guide delineates high-potential research areas, supported by mechanistic insights and validated protocols.

Part 1: Medicinal Chemistry & Oncology

The 1,2,4-Triazole as a Kinase Inhibitor

The 1,2,4-triazole ring is extensively utilized to target ATP-binding pockets of kinases. Its capacity to form hydrogen bonds (acting as both donor and acceptor) allows it to mimic the purine ring of ATP, facilitating tight binding in the hinge region of enzymes like c-Met and VEGFR.

Current Research Focus:

- **Dual-Targeting Agents:** Developing Multitarget-Directed Ligands (MTDLs) that inhibit multiple pathways simultaneously (e.g., c-Met/VEGFR dual inhibitors) to overcome compensatory resistance mechanisms in cancer cells.
- **Bioisosterism:** Replacing unstable amide linkages in peptide-based drugs with 1,2,4-triazoles to improve half-life without sacrificing binding affinity.

Quantitative Insight: Potency of Recent Triazole Derivatives

Recent studies (e.g., Mortazavi et al., 2022) have highlighted the efficacy of quinazolinone-triazole hybrids.

Compound ID	Target Kinase	IC50 (μM)	Mechanism of Action
CM9	c-Met	22.76	Competitive ATP inhibition; H-bonding with hinge region residues.
CM9	VEGFR3 (FLT4)	5.01	Angiogenesis suppression via receptor tyrosine kinase inhibition.
Cabozantinib	c-Met / VEGFR2	\sim 0.035	Reference standard (FDA Approved); Type II inhibitor.

Triazoles in PROTACs (Targeted Protein Degradation)

The 1,2,3-triazole, generated via "Click Chemistry" (CuAAC), has become the gold-standard linker for PROTACs.

- **Why Triazoles?** Unlike flexible alkyl chains, the triazole ring adds rigidity, which can pre-organize the molecule for better ternary complex formation (Target-PROTAC-E3 Ligase).
- **Metabolic Stability:** The triazole ring is inert to most peptidases and esterases, prolonging the in vivo duration of the degrader.

Part 2: Antifungal Pharmacology & Resistance

Mechanism of Action: The Ergosterol Checkpoint

Triazole antifungals (e.g., Voriconazole, Posaconazole) target Lanosterol 14

-demethylase (CYP51).[1][2] This enzyme is critical for converting lanosterol to ergosterol, the fungal equivalent of cholesterol. Inhibition leads to the accumulation of toxic methylated sterols and membrane rupture.[3]

Emerging Research Area:

- **Secondary Mechanism:** Recent evidence suggests triazoles also trigger a negative feedback loop on HMG-CoA Reductase, further shutting down sterol production.[4]
- **Resistance Breaking:** Designing "long-tailed" triazoles that can access the access channel of mutated CYP51 enzymes where traditional azoles fail.

Visualization: The Ergosterol Inhibition Pathway

The following diagram illustrates the specific blockade point of triazole drugs within the fungal sterol pathway.

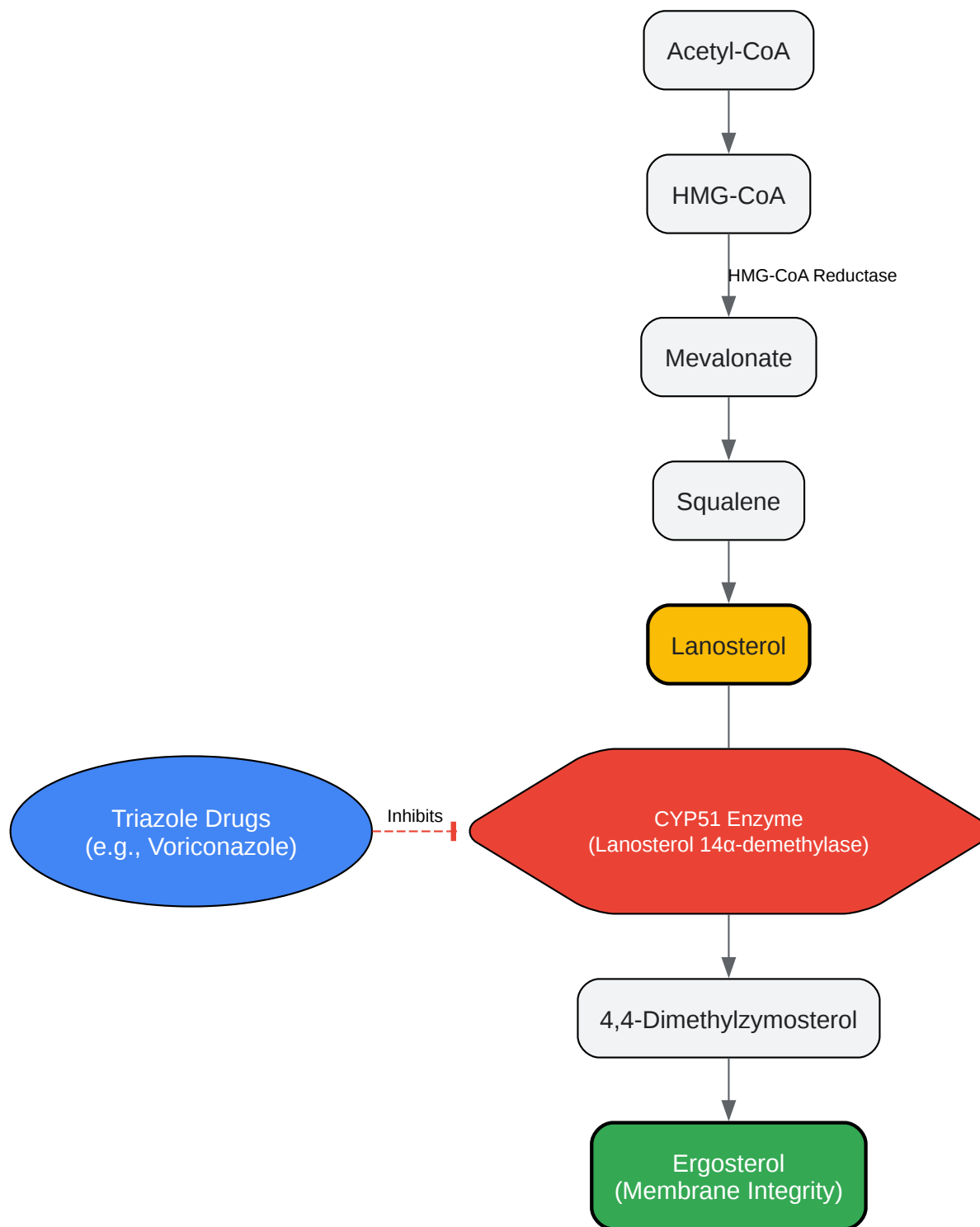

[Click to download full resolution via product page](#)

Figure 1: Mechanism of Action for Triazole Antifungals.[1][4] The drug blocks CYP51, preventing the conversion of Lanosterol to Ergosterol, leading to membrane failure.

Part 3: Materials Science (Corrosion Inhibition)

Triazole derivatives are premier corrosion inhibitors for copper and mild steel in acidic environments (e.g., HCl pickling solutions).

- Mechanism: Chemisorption. The nitrogen lone pairs and the π -electron cloud of the triazole ring donate electrons to the empty d -orbitals of the metal surface (coordinate bond), while the metal back-donates electrons to the triazole anti-bonding orbitals (retro-donation).
- Research Frontier: Self-healing coatings. Encapsulating triazole inhibitors into nanocontainers (e.g., halloysite nanotubes) that release the inhibitor only when the coating is damaged.

Part 4: Experimental Protocol

Optimized CuAAC "Click" Synthesis for 1,4-Disubstituted 1,2,3-Triazoles

This protocol is designed for high-fidelity synthesis of triazole linkers, suitable for PROTACs or bioconjugation. It uses TBTA to stabilize the Cu(I) oxidation state, preventing catalytic death by oxidation.[5]

Workflow Diagram

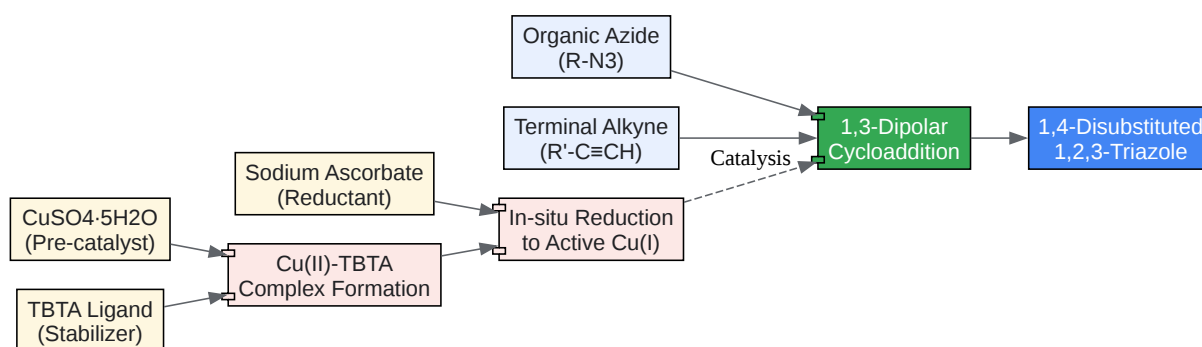

[Click to download full resolution via product page](#)

Figure 2: Step-by-step reaction flow for Copper-Catalyzed Azide-Alkyne Cycloaddition (CuAAC).

Step-by-Step Methodology

- Reagent Preparation:
 - Solvent: t-Butanol/Water (1:1 v/v). Why: Water accelerates the reaction; t-Butanol solubilizes organic reactants.
 - Catalyst Mix: Premix CuSO₄·5H₂O (1 mol%) and TBTA (1.1 mol%) in water/DMSO.
- Reaction Setup:
 - Dissolve Alkyne (1.0 eq) and Azide (1.0 eq) in the solvent mixture.
 - Add the Catalyst Mix to the reaction vessel.

- Initiation: Add Sodium Ascorbate (freshly prepared 1M solution, 5 mol%) dropwise. The solution should turn bright yellow (indicating Cu(I)-TBTA complex).
- Incubation:
 - Stir at Room Temperature (RT) for 1–12 hours. Monitor via TLC or LC-MS.
- Workup (Self-Validating):
 - Dilute with water. If the product precipitates (common for triazoles), filter and wash with cold water.^[6]
 - If extraction is needed, use EtOAc. The copper stays in the aqueous phase (blue color upon re-oxidation).
 - Purification: Recrystallization is often sufficient; column chromatography is rarely needed due to the high specificity of the reaction.

References

- Recent Advances in 1,2,4-Triazole-Based Anticancer Agents (2025) Source: PubMed / Wiley Online Library [\[Link\]](#)
- Editorial: Pharmaceutical Insights into the Triazoles Source: Frontiers in Chemistry [\[Link\]](#)
- A Secondary Mechanism of Action for Triazole Antifungals Source: Nature Communications / NIH [\[Link\]](#)
- An Overview on the Performance of 1,2,3-Triazole Derivatives as Corrosion Inhibitors Source: MDPI (Int. J. Mol. Sci.) [\[Link\]](#)^{[1][5][7][8][9][10][11][12][13][14][15][16]}
- Triazole-Based PROTACs: Linker Design and Impact Source: ACS Medicinal Chemistry Letters [\[Link\]](#)

Need Custom Synthesis?

BenchChem offers custom synthesis for rare earth carbides and specific isotopic labeling.

Email: info@benchchem.com or [Request Quote Online](#).

Sources

- 1. [Frontiers | Ergosterol biosynthesis in Aspergillus fumigatus: its relevance as an antifungal target and role in antifungal drug resistance \[frontiersin.org\]](#)
- 2. [Antifungal Ergosterol Synthesis Inhibitors - StatPearls - NCBI Bookshelf \[ncbi.nlm.nih.gov\]](#)
- 3. [researchgate.net \[researchgate.net\]](#)
- 4. [A secondary mechanism of action for triazole antifungals in Aspergillus fumigatus mediated by hmg1 - PMC \[pmc.ncbi.nlm.nih.gov\]](#)
- 5. [broadpharm.com \[broadpharm.com\]](#)
- 6. [researchgate.net \[researchgate.net\]](#)
- 7. [Alkyne Azide Click Chemistry Protocol for ADC Bioconjugation with Real Examples | AxisPharm \[axispharm.com\]](#)
- 8. [pubs.acs.org \[pubs.acs.org\]](#)
- 9. [mdpi.com \[mdpi.com\]](#)
- 10. [Click Chemistry \[organic-chemistry.org\]](#)
- 11. [ijcsi.pro \[ijcsi.pro\]](#)
- 12. [An Optimal “Click” Formulation Strategy for Antibody-Drug Conjugate Synthesis - PMC \[pmc.ncbi.nlm.nih.gov\]](#)
- 13. [A Review on 1,2,4-Triazole Derivatives as Corrosion Inhibitors \[ouci.dntb.gov.ua\]](#)
- 14. [Recent advances in the molecular design and applications of proteolysis targeting chimera-based multi-specific antiviral modality – ScienceOpen \[scienceopen.com\]](#)
- 15. [Recent Advances in PROTACs for Drug Targeted Protein Research - PMC \[pmc.ncbi.nlm.nih.gov\]](#)
- 16. [jenabioscience.com \[jenabioscience.com\]](#)
- To cite this document: BenchChem. [Technical Deep Dive: Strategic Research Frontiers for Triazole-Based Compounds]. BenchChem, [2026]. [Online PDF]. Available at: [\[https://www.benchchem.com/product/b1280476/docs#technical-deep-dive-strategic-research-frontiers-for-triazole-based-compounds\]](https://www.benchchem.com/product/b1280476/docs#technical-deep-dive-strategic-research-frontiers-for-triazole-based-compounds)

Disclaimer & Data Validity:

The information provided in this document is for Research Use Only (RUO) and is strictly not intended for diagnostic or therapeutic procedures. While BenchChem strives to provide accurate protocols, we make no warranties, express or implied, regarding the fitness of this product for every specific experimental setup.

Technical Support: The protocols provided are for reference purposes. Unsure if this reagent suits your experiment?

Need Industrial/Bulk Grade? [Request Custom Synthesis Quote](#)

BenchChem

Our mission is to be the trusted global source of essential and advanced chemicals, empowering scientists and researchers to drive progress in science and industry.

Contact

Address: 3281 E Guasti Rd
Ontario, CA 91761, United States
Phone: (601) 213-4426
Email: info@benchchem.com

[Contact our Ph.D. Support Team for a compatibility check](#)