

Replicating Key Experiments on Fuegin's Efficacy: A Comparative Guide

Author: BenchChem Technical Support Team. **Date:** April 2026

Compound of Interest

Compound Name: Fuegin
Cat. No.: B128050

[Get Quote](#)

For Researchers, Scientists, and Drug Development Professionals

This guide provides a comparative analysis of the efficacy of the novel MEK1/2 inhibitor, **Fuegin**, against the established therapeutic agent, Trametinib, in the context of BRAF V600E mutant melanoma. The following sections detail the experimental protocols for key in vitro and in vivo studies, present the comparative efficacy data in a structured format, and illustrate the underlying signaling pathway and experimental workflows.

Comparative Efficacy Data

The following tables summarize the quantitative data from key experiments comparing the efficacy of **Fuegin** and Trametinib.

Table 1: In Vitro Cell Viability Assay (IC50)

Compound	Cell Line (BRAF V600E)	IC50 (nM)
Fuegin	A375	0.5
SK-MEL-28	1.2	
Trametinib	A375	0.8
SK-MEL-28	1.5	

Table 2: In Vivo Tumor Growth Inhibition in A375 Xenograft Model

Treatment Group (n=10)	Dose (mg/kg, oral, daily)	Tumor Growth Inhibition (%)	p-value vs. Vehicle
Vehicle Control	-	0	-
Fuegin	1	85	<0.001
Trametinib	1	82	<0.001

Experimental Protocols

Detailed methodologies for the key experiments cited above are provided below.

In Vitro Cell Viability Assay

Objective: To determine the half-maximal inhibitory concentration (IC50) of **Fuegin** and Trametinib on the proliferation of BRAF V600E mutant melanoma cell lines.

Materials:

- A375 and SK-MEL-28 human melanoma cell lines
- RPMI-1640 medium supplemented with 10% fetal bovine serum (FBS) and 1% penicillin-streptomycin
- **Fuegin** and Trametinib (dissolved in DMSO)
- CellTiter-Glo® Luminescent Cell Viability Assay kit

- 96-well microplates
- Luminometer

Procedure:

- Seed A375 and SK-MEL-28 cells in 96-well plates at a density of 5,000 cells per well and incubate for 24 hours at 37°C in a 5% CO₂ incubator.
- Prepare serial dilutions of **Fuegin** and Trametinib in culture medium.
- Treat the cells with varying concentrations of the compounds for 72 hours.
- After the incubation period, allow the plates to equilibrate to room temperature.
- Add CellTiter-Glo® reagent to each well according to the manufacturer's instructions.
- Measure the luminescence using a luminometer.
- Calculate the IC₅₀ values by plotting the percentage of cell viability against the logarithm of the drug concentration and fitting the data to a sigmoidal dose-response curve.

In Vivo Tumor Growth Inhibition

Objective: To evaluate the in vivo efficacy of **Fuegin** and Trametinib in a mouse xenograft model of human melanoma.

Materials:

- Female athymic nude mice (6-8 weeks old)
- A375 human melanoma cells
- Matrigel
- **Fuegin** and Trametinib (formulated for oral administration)
- Vehicle control solution

- Calipers

Procedure:

- Subcutaneously implant 5×10^6 A375 cells mixed with Matrigel into the flank of each mouse.
- Monitor tumor growth regularly. When tumors reach an average volume of 150-200 mm³, randomize the mice into treatment groups (n=10 per group).
- Administer **Fuegin** (1 mg/kg), Trametinib (1 mg/kg), or vehicle control orally once daily for 21 days.
- Measure tumor dimensions with calipers every 3 days and calculate tumor volume using the formula: $(\text{Length} \times \text{Width}^2) / 2$.
- At the end of the study, euthanize the mice and excise the tumors for further analysis.
- Calculate the percentage of tumor growth inhibition for each treatment group relative to the vehicle control group.

Visualizations

Signaling Pathway of Fuegin

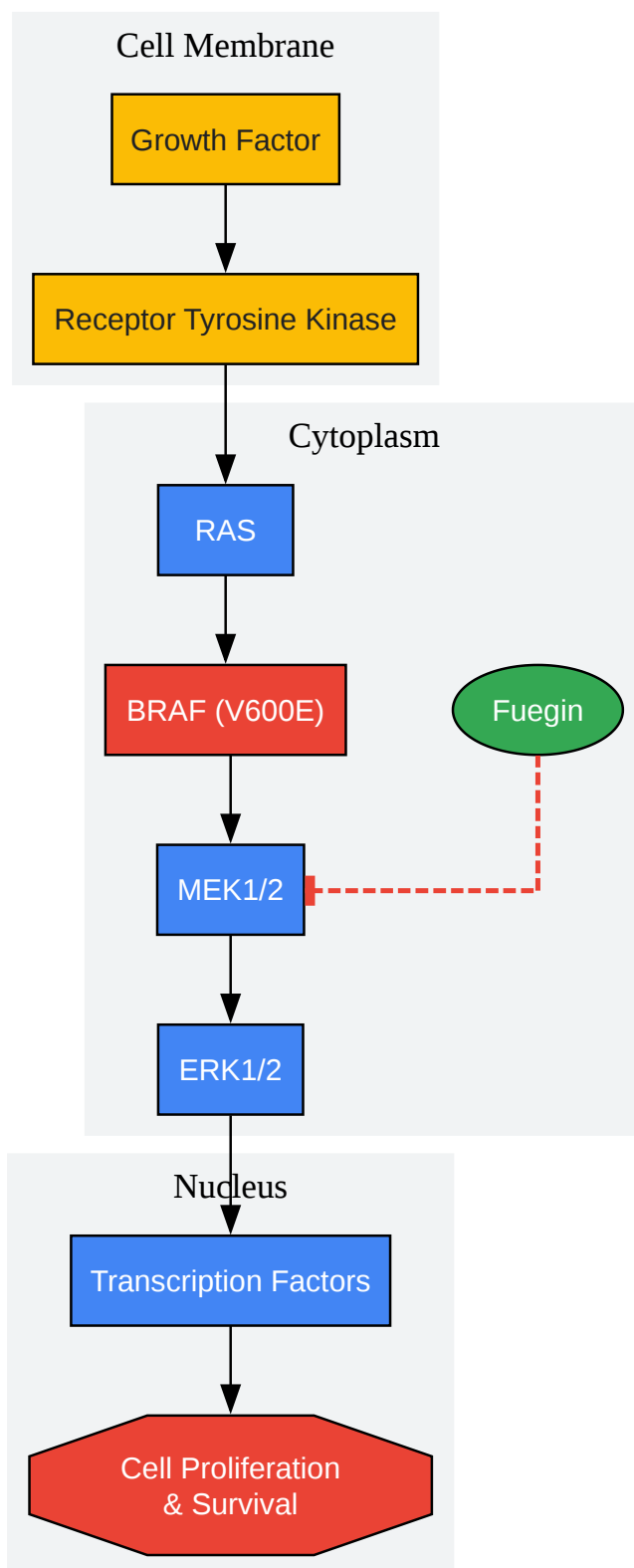

[Click to download full resolution via product page](#)

Caption: **Fuegin**'s mechanism of action in the MAPK signaling pathway.

Experimental Workflow for In Vivo Efficacy Study

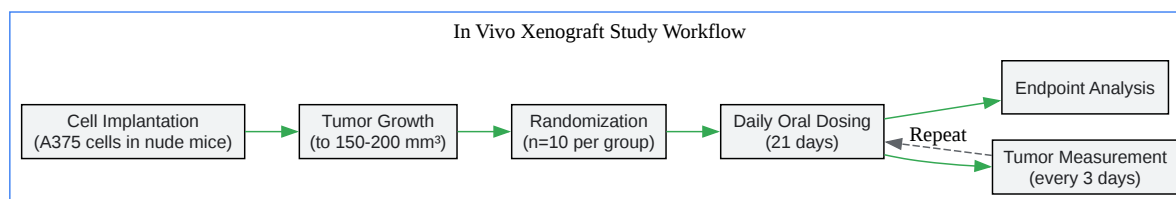

[Click to download full resolution via product page](#)

Caption: Workflow for the in vivo tumor growth inhibition study.

- To cite this document: BenchChem. [Replicating Key Experiments on Fuegin's Efficacy: A Comparative Guide]. BenchChem, [2026]. [Online PDF]. Available at: [\[https://www.benchchem.com/product/b128050/docs#replicating-key-experiments-on-fuegin-s-efficacy-a-comparative-guide\]](https://www.benchchem.com/product/b128050/docs#replicating-key-experiments-on-fuegin-s-efficacy-a-comparative-guide)

Disclaimer & Data Validity:

The information provided in this document is for Research Use Only (RUO) and is strictly not intended for diagnostic or therapeutic procedures. While BenchChem strives to provide accurate protocols, we make no warranties, express or implied, regarding the fitness of this product for every specific experimental setup.

Technical Support: The protocols provided are for reference purposes. Unsure if this reagent suits your experiment?

Need Industrial/Bulk Grade? [Request Custom Synthesis Quote](#)

BenchChem

Our mission is to be the trusted global source of essential and advanced chemicals, empowering scientists and researchers to drive progress in science and industry.

Contact

Address: 3281 E Guasti Rd

Ontario, CA 91761, United States

Phone: (601) 213-4426

Email: info@benchchem.com

[Contact our Ph.D. Support Team for a compatibility check](#)