

GC-MS analysis of Methylene dithiocyanate in soil samples

Author: BenchChem Technical Support Team. **Date:** May 2026

Compound of Interest

Compound Name: *Methylene dithiocyanate*

CAS No.: 6317-18-6

Cat. No.: B128318

[Get Quote](#)

Application Note: High-Sensitivity GC-MS Determination of **Methylene Dithiocyanate** (MTC) in Soil Matrices

Abstract This application note details a robust protocol for the extraction and quantification of **Methylene dithiocyanate** (MTC) in soil using Gas Chromatography-Mass Spectrometry (GC-MS). MTC (CAS 6317-18-6) is a broad-spectrum biocide widely used in industrial cooling towers and timber preservation. Its analysis in soil is complicated by two primary factors: rapid hydrolysis at alkaline pH and thermal instability during gas chromatographic injection. This guide introduces a Modified Acidic-QuEChERS extraction workflow coupled with Programmed Temperature Vaporization (PTV) injection to minimize thermal degradation and ensure sub-ppm detection limits.

Introduction & Analytical Challenges

Methylene dithiocyanate (MTC) is an organosulfur compound (

) effective against slime-forming bacteria and fungi. Upon release into the soil, its persistence is dictated by pH; it is relatively stable in acidic environments but hydrolyzes rapidly in basic soils to form thiocyanate ions (

) and formaldehyde.

The GC-MS Paradox: While High-Performance Liquid Chromatography (HPLC) is often the default for thermally labile compounds, GC-MS offers superior selectivity for complex soil matrices if thermal degradation can be managed. MTC tends to decompose in standard hot split/splitless injectors (

), leading to poor reproducibility and the formation of breakdown products like methyl isothiocyanate (MITC).

Strategic Solution:

- Stabilization: Extraction using acidified acetonitrile to inhibit hydrolysis.
- Thermal Management: Utilization of a PTV inlet or "Cool On-Column" injection to introduce the analyte at a low temperature () before ramping, preventing flash decomposition.

Experimental Protocol

Reagents & Standards

- Target Analyte: **Methylene dithiocyanate** (>98% purity).
- Internal Standard (IS): Naphthalene-d8 or 1,4-Dichlorobenzene-d4 (chosen for retention time proximity without chemical interference).
- Solvents: Acetonitrile (LC-MS grade), Formic Acid (98%), Magnesium Sulfate (anhydrous), Sodium Chloride.
- Matrix: Blank soil (sandy loam) for matrix-matched calibration.

Sample Preparation: Modified Acidic-QuEChERS

Standard QuEChERS uses citrate buffers (pH 5-5.5), but MTC requires stricter acidification (pH < 4) for maximum stability.

Step-by-Step Extraction Workflow:

- Weighing: Weigh 10.0 g of homogenized soil into a 50 mL PTFE centrifuge tube.
- Acidification: Add 10 mL of 1% Formic Acid in Acetonitrile.
 - Expert Insight: The formic acid neutralizes soil alkalinity immediately, preventing MTC hydrolysis.
- Agitation: Vortex for 1 min, then shake vigorously for 15 min on a mechanical shaker.
- Salting Out: Add 4 g
and 1 g
. Shake immediately for 1 min to prevent clump formation.
 - Note: Avoid citrate buffers; simple salting out is preferred to keep the organic phase acidic.
- Centrifugation: Centrifuge at 4,000 rpm for 5 min.
- Clean-up (dSPE): Transfer 1 mL of supernatant to a dSPE tube containing 150 mg
and 50 mg C18.
 - Critical: Do NOT use PSA (Primary Secondary Amine). PSA is basic and will induce MTC degradation. Use C18 to remove lipids/waxes.
- Filtration: Filter extract through a 0.2 µm PTFE syringe filter into a GC vial. Add Internal Standard.

GC-MS Instrumentation & Conditions

Instrument: Agilent 7890B GC / 5977B MSD (or equivalent).

Inlet Parameters (The Critical Control Point)

- Inlet Mode: Programmed Temperature Vaporization (PTV) - Solvent Vent Mode.
 - Why? Allows injection at cold temperatures, eliminating thermal shock.
- Injection Volume: 2 µL.

- Temperature Program:
 - Initial:
(Hold 0.5 min).
 - Ramp:
/min to
.
 - Vent Flow: 50 mL/min at 20 kPa.
- Alternative (if PTV unavailable): Pulsed Splitless at
(Keep inlet as cool as possible while ensuring volatilization).

Column & Oven

- Column: DB-5MS Ultra Inert (30 m
0.25 mm
0.25 μ m).
- Carrier Gas: Helium @ 1.2 mL/min (Constant Flow).
- Oven Program:
 - (Hold 2 min).
 - /min to
.
 - /min to
(Hold 3 min).

Mass Spectrometer (SIM Mode)

MTC fragments extensively. Selected Ion Monitoring (SIM) is required for sensitivity.

Analyte	Retention Time (min)	Quant Ion (m/z)	Qualifier Ions (m/z)
Methylene dithiocyanate	~8.5	72 ()	45 (), 130 ()
Naphthalene-d8 (IS)	~9.2	136	108, 68

Note: The molecular ion (130) is often weak; m/z 72 is the base peak used for quantification.

Visual Workflows

Figure 1: Modified Acidic-QuEChERS Extraction Logic

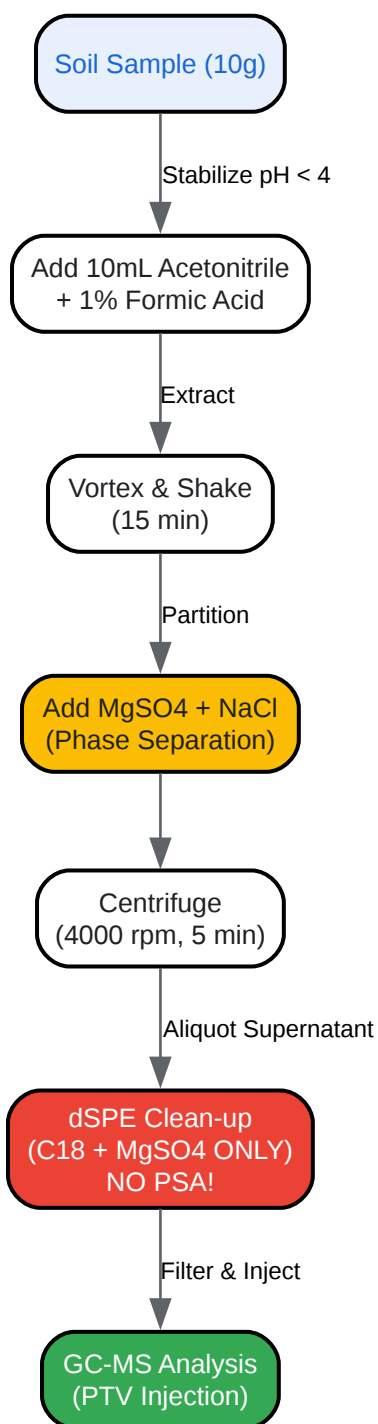

[Click to download full resolution via product page](#)

Caption: Workflow emphasizing acidification and avoidance of basic sorbents (PSA) to prevent MTC degradation.

Figure 2: Thermal Degradation Control in GC Inlet

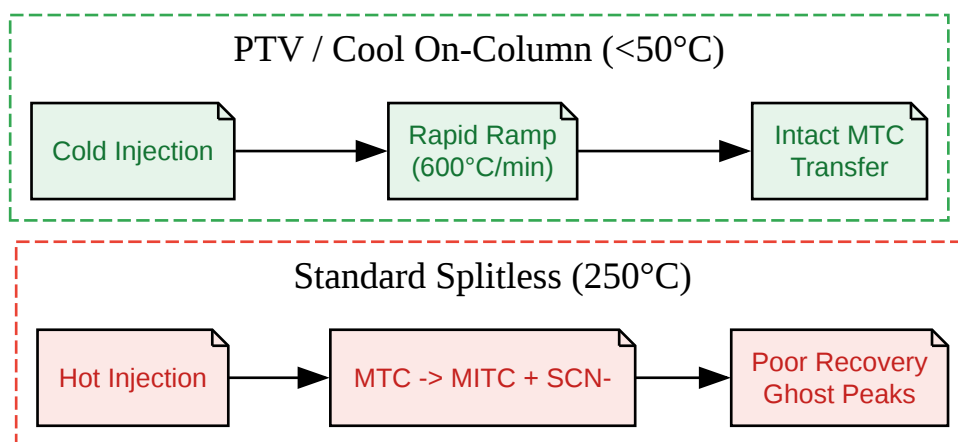

[Click to download full resolution via product page](#)

Caption: Comparison of standard hot injection vs. PTV injection, highlighting the necessity of cold introduction for labile MTC.

Validation & QA/QC

To ensure data trustworthiness (Trustworthiness in E-E-A-T), the following criteria must be met:

Parameter	Acceptance Criteria	Notes
Linearity ()		Range: 0.05 – 5.0 mg/kg.
Recovery	70% – 110%	Spiked at 0.1 and 1.0 mg/kg.
Precision (RSD)		n=5 replicates.
LOD/LOQ	~0.02 / 0.05 mg/kg	Dependent on soil matrix complexity.
Stability Check	degradation	Analyze standard every 10 samples to check for on-column degradation.

Troubleshooting Guide:

- Issue: Low response or tailing peaks.
 - Cause: Active sites in the liner or column.
 - Fix: Use Ultra-Inert liners with glass wool removed (or placed low). Trim column inlet by 10 cm.
- Issue: Presence of peak at m/z 73 (MITC).
 - Cause: Thermal breakdown in the injector.
 - Fix: Lower inlet temperature or increase carrier gas flow during injection pulse.

References

- U.S. Environmental Protection Agency (EPA). (1995). Reregistration Eligibility Decision (RED): Methylene bis(thiocyanate). EPA 738-R-95-028. Retrieved from [[Link](#)]
- National Institute of Standards and Technology (NIST). (2023). **Methylene dithiocyanate** Mass Spectrum (NIST# 292084). NIST Chemistry WebBook, SRD 69. Retrieved from [[Link](#)]
- European Chemicals Agency (ECHA). (2022). Assessment Report: **Methylene dithiocyanate** Product Type 12. Biocidal Products Committee. Retrieved from [[Link](#)]
- Anastassiades, M., et al. (2003). *Fast and Easy Multiresidue Method Employing Acetonitrile Extraction/Partitioning and "Dispersive Solid-Phase Extraction"
- To cite this document: BenchChem. [GC-MS analysis of Methylene dithiocyanate in soil samples]. BenchChem, [2026]. [Online PDF]. Available at: [<https://www.benchchem.com/product/b128318/docs#gc-ms-analysis-of-methylene-dithiocyanate-in-soil-samples>]

Disclaimer & Data Validity:

The information provided in this document is for Research Use Only (RUO) and is strictly not intended for diagnostic or therapeutic procedures. While BenchChem strives to provide accurate protocols, we make no warranties, express or implied, regarding the fitness of this product for every specific experimental setup.

Technical Support: The protocols provided are for reference purposes. Unsure if this reagent suits your experiment?

Need Industrial/Bulk Grade? [Request Custom Synthesis Quote](#)

BenchChem

Our mission is to be the trusted global source of essential and advanced chemicals, empowering scientists and researchers to drive progress in science and industry.

Contact

Address: 3281 E Guasti Rd
Ontario, CA 91761, United States
Phone: (601) 213-4426
Email: info@benchchem.com

[Contact our Ph.D. Support Team for a compatibility check](#)