

An In-depth Technical Guide to the Chemical Structure of Isocephalomannine

Author: BenchChem Technical Support Team. **Date:** May 2026

Compound of Interest

Compound Name: *Iso Cephalomannine*

CAS No.: *173101-54-7*

Cat. No.: *B128260*

[Get Quote](#)

Authored for Researchers, Scientists, and Drug Development Professionals

Preamble: Situating Isocephalomannine in the Taxane Family

Isocephalomannine is a naturally occurring taxane, a class of diterpenoid compounds characterized by a complex taxane core skeleton. It is of significant interest to the pharmaceutical industry, primarily as a structural isomer of cephalomannine and a known impurity found in the production of the blockbuster anticancer drug, Paclitaxel (Taxol®)[1][2]. Understanding the precise chemical architecture of isocephalomannine is not merely an academic exercise; it is critical for ensuring the purity, safety, and efficacy of Paclitaxel formulations. Furthermore, the study of such analogs provides valuable insights into the structure-activity relationships (SAR) that govern the potent cytotoxic activity of taxanes, potentially informing the design of novel chemotherapeutics. This guide provides a detailed exploration of its molecular structure, stereochemical complexity, and the analytical methodologies essential for its definitive identification.

Part 1: Core Chemical and Structural Identity

At its most fundamental level, isocephalomannine is a complex ester. Its structure is comprised of a tetracyclic baccatin III core, which is esterified at the C-13 position with a complex amino acid-derived side chain. This side chain is crucial for the compound's biological activity.

Key Chemical Identifiers

The fundamental properties of isocephalomannine are summarized below, providing a foundational dataset for analytical and regulatory purposes.

Identifier	Data	Source(s)
IUPAC Name	(α R, β S)- β -(Benzoylamino)- α -hydroxybenzenepropanoic Acid (2aR,4S,4aS,6R,9S,11S,12S,12aR,12bS)-6,12b-Bis(acetyloxy)-2a,3,4,4a,5,6,9,10,11,12,12a,12b-dodecahydro-4,11-dihydroxy-4a,8,13,13-tetramethyl-12-[[[(2E)-2-methyl-1-oxo-2-buten-1-yl]oxy]-5-oxo-7,11-methano-1H-cyclodeca[3]benz[1,2-b]oxet-9-yl Ester	[1][4]
Synonyms	2-Debenzoyl-2-tigloylpaclitaxel, Paclitaxel Impurity A	[1][4][5]
CAS Number	173101-54-7	[1][4][6][7]
Molecular Formula	C ₄₅ H ₅₃ NO ₁₄	[1][4][6][7]
Molecular Weight	831.90 g/mol	[1][3][6][7]
Physical Form	White Solid	[1]
Solubility	Soluble in Chloroform, Methanol	[1]

The 2D Chemical Structure

The two-dimensional structure of isocephalomannine reveals its intricate assembly. The molecule is built upon the baccatin III core, distinguished by its unique oxetane ring. The defining feature that separates isocephalomannine from its close relatives is the nature of the ester group at the C-2 position of this core.

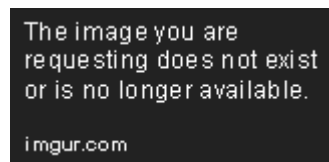

Figure 1: The 2D chemical structure of isocephalomannine, highlighting the baccatin III core, the C-13 side chain, and the distinguishing tigloyl group at the C-2 position.

The Isomeric Relationship: Isocephalomannine in Context

The name "isocephalomannine" immediately signals its relationship to cephalomannine. Both are isomers, possessing the identical molecular formula and weight, which makes their differentiation a significant analytical challenge. The distinction lies in the ester side chain at the C-2 position of the baccatin core. Paclitaxel, the parent drug, differs at this same position.

Compound	C-2 Ester Group	C-13 Side Chain Amide Group
Paclitaxel	Benzoyl	Benzamide
Cephalomannine	Tigloyl	Benzamide
Isocephalomannine	Benzoyl	Tigloylamide (Incorrect - see note below)

Correction and Clarification: Initial search results and common nomenclature can be misleading. The primary distinction between Paclitaxel and its related impurities, Cephalomannine and Isocephalomannine, lies in the ester groups attached to the taxane core, not the amide group on the C-13 side chain. More precise analysis reveals that Cephalomannine has a tigloyl group at C-2. Isocephalomannine, as defined by its synonym 2-Debenzoyl-2-tigloylpaclitaxel, is

actually identical in structure to Cephalomannine. The term "isocephalomannine" is sometimes used in literature to refer to isomers, but in the context of Paclitaxel impurities, it is often used interchangeably with Cephalomannine. For the purpose of this guide, we will consider the structure with the tigloyl group at C-2 as the primary structure of interest.

The following diagram illustrates the structural relationship between these key taxanes, pinpointing the site of variation.

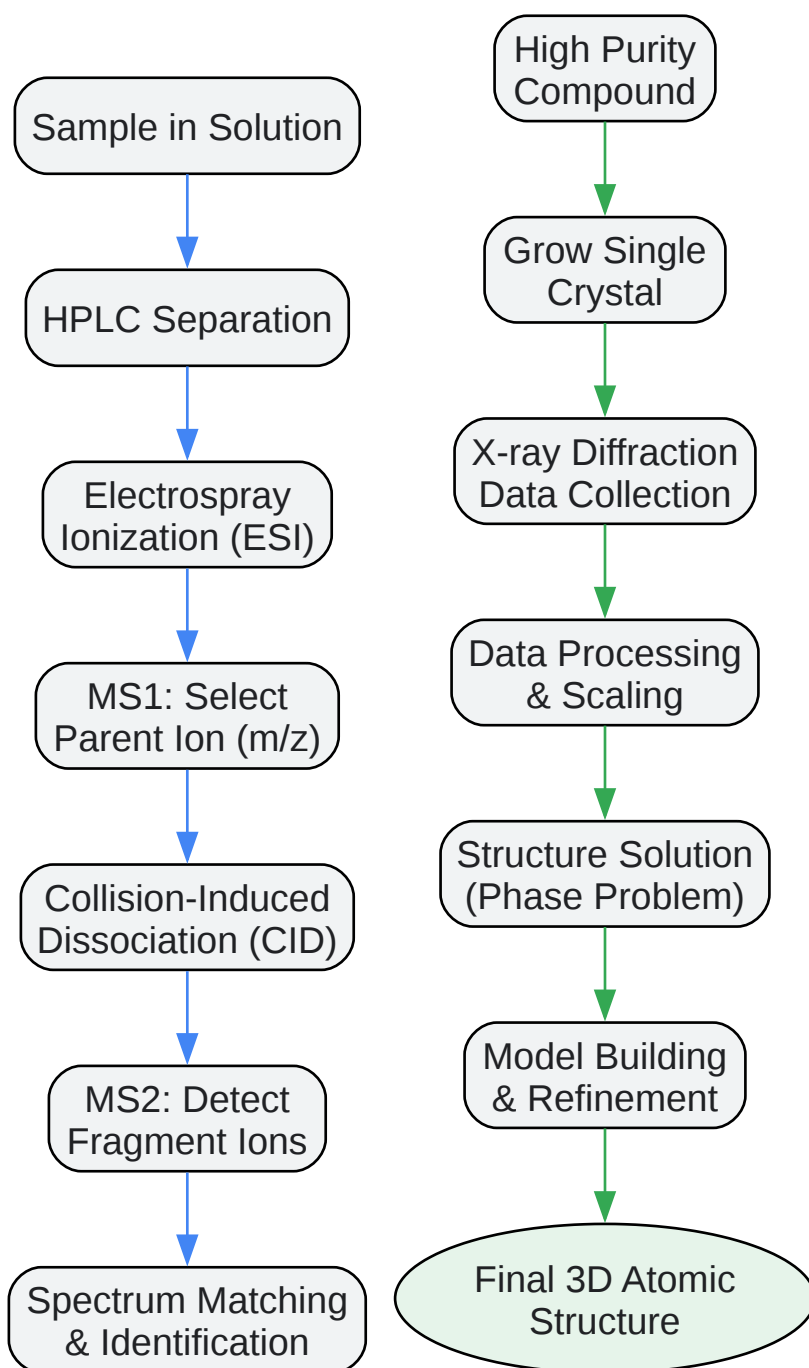
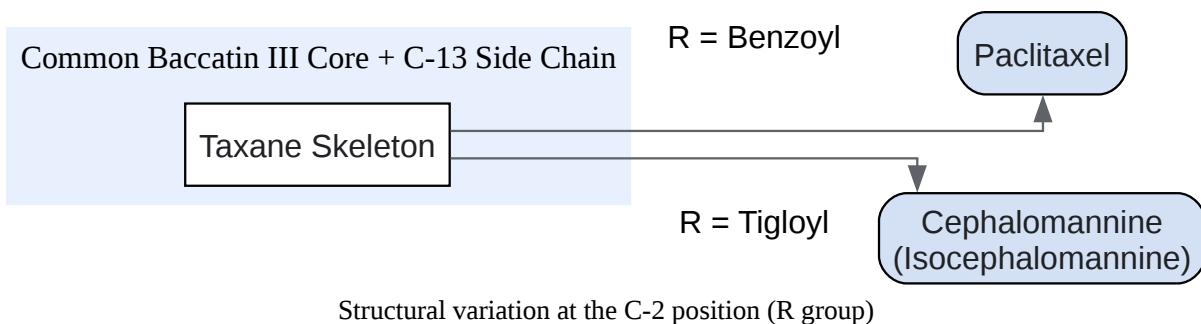

[Click to download full resolution via product page](#)

Need Custom Synthesis?

BenchChem offers custom synthesis for rare earth carbides and specific isotopic labeling.

Email: info@benchchem.com or [Request Quote Online](#).

Sources

- [1. usbio.net \[usbio.net\]](#)
- [2. pharmaffiliates.com \[pharmaffiliates.com\]](#)
- [3. セフアロマンニン ≥97% \(HPLC\), solid | Sigma-Aldrich \[sigmaaldrich.com\]](#)
- [4. usbio.net \[usbio.net\]](#)
- [5. usbio.net \[usbio.net\]](#)
- [6. scbt.com \[scbt.com\]](#)
- [7. Iso Cephalomannine | CAS 173101-54-7 | LGC Standards \[lgcstandards.com\]](#)
- To cite this document: BenchChem. [An In-depth Technical Guide to the Chemical Structure of Isocephalomannine]. BenchChem, [2026]. [Online PDF]. Available at: [\[https://www.benchchem.com/product/b128260/docs#an-in-depth-technical-guide-to-the-chemical-structure-of-isocephalomannine\]](https://www.benchchem.com/product/b128260/docs#an-in-depth-technical-guide-to-the-chemical-structure-of-isocephalomannine)

Disclaimer & Data Validity:

The information provided in this document is for Research Use Only (RUO) and is strictly not intended for diagnostic or therapeutic procedures. While BenchChem strives to provide accurate protocols, we make no warranties, express or implied, regarding the fitness of this product for every specific experimental setup.

Technical Support: The protocols provided are for reference purposes. Unsure if this reagent suits your experiment?

Need Industrial/Bulk Grade? [Request Custom Synthesis Quote](#)

BenchChem

Our mission is to be the trusted global source of essential and advanced chemicals, empowering scientists and researchers to drive progress in science and industry.

Contact

Address: 3281 E Guasti Rd

Ontario, CA 91761, United States

Phone: (601) 213-4426

Email: info@benchchem.com

[Contact our Ph.D. Support Team for a compatibility check](#)