

Magnolol: A Comparative Guide to its Clinical Potential

Author: BenchChem Technical Support Team. **Date:** May 2026

Compound of Interest

Compound Name:	Magnol
CAS No.:	92046-48-5
Cat. No.:	B12795627

[Get Quote](#)

For Researchers, Scientists, and Drug Development Professionals

Magnolol, a neolignan isolated from the bark of **Magnolia officinalis**, has emerged as a compound of significant interest in biomedical research. Traditionally used in herbal medicine, **magnolol** is now the subject of extensive preclinical investigation for its therapeutic properties across a range of diseases, most notably cancer. This guide provides an objective comparison of **magnolol**'s performance against established therapies, supported by experimental data, detailed protocols, and mechanistic diagrams to fully evaluate its clinical potential.

Mechanisms of Action: A Multi-Targeted Approach

Magnolol exerts its biological effects by modulating multiple critical signaling pathways that are often dysregulated in disease. Its ability to interfere with cancer cell proliferation, survival, and metastasis is primarily attributed to its influence on the PI3K/Akt/mTOR, MAPK, and NF- κ B signaling cascades.^{[1][2]}

PI3K/Akt/mTOR Pathway

A central regulator of cell growth, survival, and metabolism, the PI3K/Akt/mTOR pathway is a frequent target of **magnolol**. In various cancer cells, **magnolol** has been shown to inhibit the phosphorylation of Akt and mTOR, leading to the suppression of downstream signaling required for cell proliferation and survival.[3][4][5] This inhibition can induce autophagy and apoptosis.

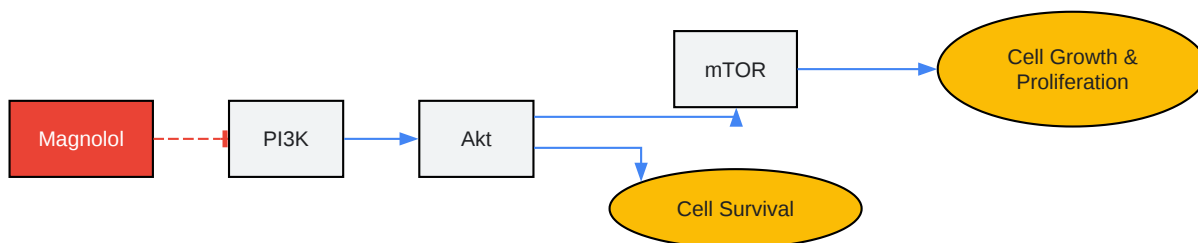

[Click to download full resolution via product page](#)

Caption: **Magnolol** inhibits the PI3K/Akt/mTOR signaling pathway.

MAPK Signaling Pathway

The Mitogen-Activated Protein Kinase (MAPK) pathway, which includes the ERK, JNK, and p38 kinases, is crucial for regulating cellular responses to external stimuli. **Magnolol**'s interaction with this pathway is complex and appears to be context-dependent. In some cancer cells, it suppresses ERK activation to inhibit proliferation, while in others, it can activate JNK and p38 to promote apoptosis.[3][6]

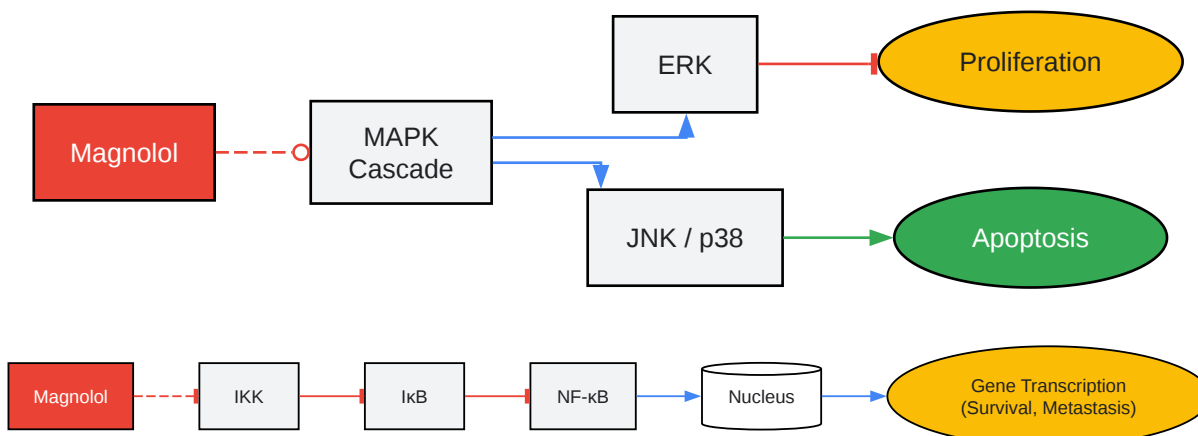

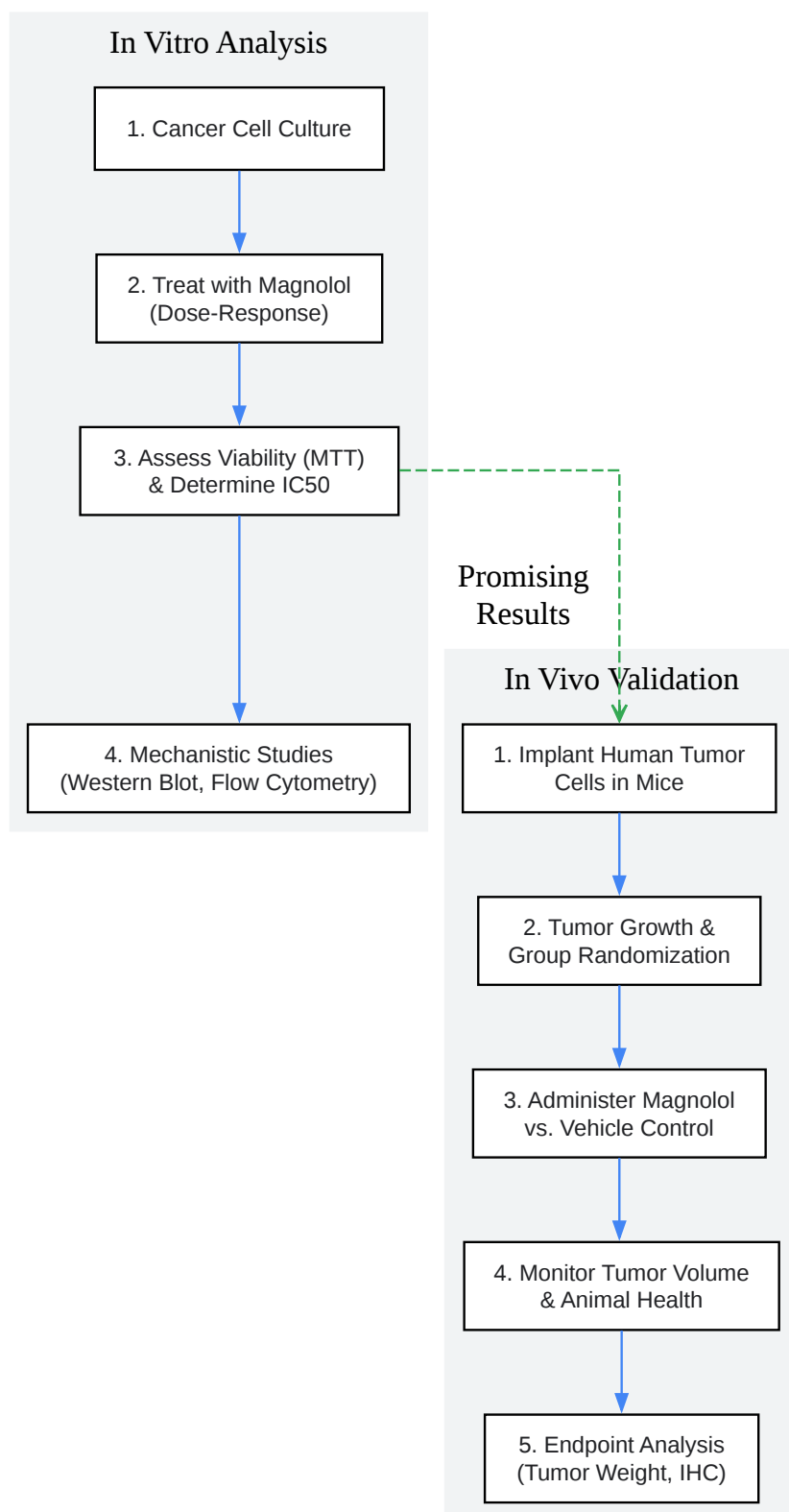

[Click to download full resolution via product page](#)

Need Custom Synthesis?

BenchChem offers custom synthesis for rare earth carbides and specific isotopic labeling.

Email: info@benchchem.com or [Request Quote Online](#).

References

- 1. Magnolol as a Potential Anticancer Agent: A Proposed Mechanistic Insight - PMC [[pmc.ncbi.nlm.nih.gov](https://pubmed.ncbi.nlm.nih.gov/)]
- 2. [mdpi.com](#) [mdpi.com]
- 3. Frontiers | Pharmacology, Toxicity, Bioavailability, and Formulation of Magnolol: An Update [[frontiersin.org](https://www.frontiersin.org/)]
- 4. [karger.com](#) [karger.com]
- 5. [mdpi.com](#) [mdpi.com]
- 6. Magnolol inhibits growth and induces apoptosis in esophagus cancer KYSE-150 cell lines via the MAP kinase pathway - PMC [[pmc.ncbi.nlm.nih.gov](https://pubmed.ncbi.nlm.nih.gov/)]
- To cite this document: BenchChem. [Magnolol: A Comparative Guide to its Clinical Potential]. BenchChem, [2026]. [Online PDF]. Available at: [<https://www.benchchem.com/product/b12795627/docs#magnolol-a-comparative-guide-to-its-clinical-potential>]

Disclaimer & Data Validity:

The information provided in this document is for Research Use Only (RUO) and is strictly not intended for diagnostic or therapeutic procedures. While BenchChem strives to provide accurate protocols, we make no warranties, express or implied, regarding the fitness of this product for every specific experimental setup.

Technical Support: The protocols provided are for reference purposes. Unsure if this reagent suits your experiment?

Need Industrial/Bulk Grade? [Request Custom Synthesis Quote](#)

BenchChem

Our mission is to be the trusted global source of essential and advanced chemicals, empowering scientists and researchers to drive progress in science and industry.

Contact

Address: 3281 E Guasti Rd

Ontario, CA 91761, United States

Phone: (601) 213-4426

Email: info@benchchem.com

[Contact our Ph.D. Support Team for a compatibility check](#)