

How to prevent tachyphylaxis with repeated phenylephrine administration

Author: BenchChem Technical Support Team. **Date:** April 2026

Compound of Interest

Compound Name: *Allerest*
Cat. No.: *B12792407*

[Get Quote](#)

Technical Support Center: Phenylephrine Tachyphylaxis

This guide provides researchers, scientists, and drug development professionals with a comprehensive resource for understanding and mitigating tachyphylaxis associated with repeated phenylephrine administration.

Frequently Asked Questions (FAQs)

Q1: What is phenylephrine-induced tachyphylaxis and what is the primary mechanism?

A1: Tachyphylaxis is a rapid decrease in the response to a drug following repeated administration. For phenylephrine, a selective α_1 -adrenergic receptor (α_1 -AR) agonist, this means that subsequent doses produce a diminished vasoconstrictive or pressor response. The primary mechanism is homologous desensitization of the α_1 -AR.^{[1][2]} This process involves:

- **Receptor Phosphorylation:** Upon agonist binding, G protein-coupled receptor kinases (GRKs) are recruited to the receptor and phosphorylate serine and threonine residues on its intracellular domains.^{[3][4]}

- **β-Arrestin Recruitment:** The phosphorylated receptor is a high-affinity binding site for β-arrestin proteins.[3][5]
- **Uncoupling:** β-arrestin binding sterically hinders the coupling of the receptor to its cognate Gq protein, thereby blocking downstream signaling cascades (e.g., PLC activation and IP3-mediated Ca²⁺ release).[4][6]
- **Internalization:** β-arrestin acts as an adaptor protein, facilitating the internalization of the receptor from the cell surface into endosomes via clathrin-coated pits.[4][7] This reduces the number of available receptors on the cell membrane.

Q2: My tissue preparation shows a reduced contractile response to phenylephrine after the first dose. How can I confirm this is receptor-specific tachyphylaxis?

A2: To confirm that the diminished response is due to α₁-AR tachyphylaxis and not general tissue fatigue or viability issues, you should perform control experiments. A common method is to assess the response to a receptor-independent vasoconstrictor, such as potassium chloride (KCl). A high concentration of KCl depolarizes the smooth muscle cell membrane, causing vasoconstriction by opening voltage-gated Ca²⁺ channels, bypassing the α₁-AR. If the tissue contracts robustly in response to KCl after tachyphylaxis to phenylephrine has been established, it suggests the contractile machinery is intact and the desensitization is specific to the α₁-AR pathway.[8]

Q3: Are there dosing strategies that can minimize the development of tachyphylaxis?

A3: Yes, altering the dosing regimen can impact the degree of tachyphylaxis.

- **Intermittent Bolus Dosing:** Administering phenylephrine as intermittent boluses rather than a continuous infusion may allow for some degree of receptor resensitization between doses.[9][10] The "off" period allows for dephosphorylation and recycling of receptors back to the cell surface.
- **Lower Doses:** Using the minimum effective dose can reduce the intensity of receptor activation and subsequent desensitization. Studies in clinical settings suggest that lower infusion rates are associated with fewer adverse hemodynamic events, which may be related to mitigating tachyphylaxis.[11]

Q4: Can co-administration of other pharmacological agents prevent phenylephrine tachyphylaxis?

A4: Yes, targeting the molecular machinery of desensitization is a key experimental strategy.

- **GRK2 Inhibitors:** Since GRK2 is a primary kinase involved in α 1-AR phosphorylation, its inhibition can attenuate desensitization.^{[12][13]} Small molecule inhibitors like paroxetine (at concentrations that inhibit GRK2) or more specific research compounds can be used in ex vivo and in vitro models to prevent the initial step of desensitization.^[13]
- **Nitric Oxide Synthase (NOS) Inhibitors:** In some vascular beds, prolonged α 1-AR stimulation can increase the expression of neuronal NOS (nNOS) or endothelial NOS (eNOS). The resulting nitric oxide (NO) production can lead to cGMP-mediated uncoupling of the α 1-AR from its G protein.^{[6][14]} Inhibiting NOS with agents like L-NAME may prevent this form of desensitization.^{[6][15]}

Troubleshooting Guides

Problem 1: Complete loss of response to phenylephrine in an isolated aortic ring preparation.

Possible Cause	Troubleshooting Step	Expected Outcome
Severe Tachyphylaxis	After washout, challenge the tissue with 60-80 mM KCl.	A strong contraction indicates the tissue is viable and the issue is receptor-specific.
Tissue Death/Damage	Challenge with KCl.	No or very weak contraction suggests the tissue is no longer viable. Check dissection technique and buffer oxygenation.
Incorrect Drug Concentration	Verify the calculations and stock solution concentration for phenylephrine.	Preparing a fresh, correctly concentrated solution should restore the expected response in a naive tissue.
Endothelial Damage	Test for endothelium-dependent relaxation with acetylcholine (ACh) in a pre-constricted ring.	If no relaxation occurs with ACh, the endothelium is damaged, which can alter NO-mediated feedback mechanisms. [14]

Problem 2: High variability in the degree of tachyphylaxis between experiments.

Possible Cause	Troubleshooting Step	Expected Outcome
Inconsistent Incubation Times	Strictly standardize the duration of phenylephrine exposure and washout periods between dose-response curves.	Reduced variability in the rightward shift of the EC50 or reduction in Emax.
Differences in Animal Age/Strain	Ensure all experiments use animals from the same source, strain, and narrow age range.	Age can affect desensitization mechanisms, so standardization will improve consistency. [14]
Variable Endothelial Integrity	Be meticulous and consistent during the dissection process to either preserve or denude the endothelium uniformly.	Consistent endothelial function will normalize the contribution of NO to the desensitization process. [16]

Data Summary Tables

Table 1: Effect of Repeated Phenylephrine (PE) Administration on Aortic Ring Contraction (Illustrative data based on typical experimental findings)

Parameter	First Dose-Response Curve (CRC1)	Second Dose-Response Curve (CRC2)	% Change
Emax (% of KCl max)	98.5 ± 2.1%	65.3 ± 3.5%	-33.7%
EC50 (nM)	150 ± 12 nM	850 ± 45 nM	+467%

Table 2: Effect of GRK2 Inhibitor on Phenylephrine-Induced Tachyphylaxis (Illustrative data)

Treatment Group	Parameter	First Dose-Response Curve (CRC1)	Second Dose-Response Curve (CRC2)
Vehicle Control	Emax (% of KCl max)	97.9 ± 2.8%	62.1 ± 4.0%
EC50 (nM)	162 ± 15 nM	910 ± 52 nM	
GRK2 Inhibitor (e.g., Paroxetine 10µM)	Emax (% of KCl max)	98.2 ± 3.1%	91.5 ± 3.8%
EC50 (nM)	155 ± 18 nM	250 ± 25 nM	

Key Experimental Protocols

Protocol 1: Assessment of Phenylephrine-Induced Tachyphylaxis in Isolated Rat Aortic Rings

Objective: To quantify the desensitization of the contractile response to phenylephrine in isolated vascular tissue.

Materials:

- Male Wistar rats (250-300g)
- Krebs-Henseleit solution (in mM: 119 NaCl, 4.7 KCl, 2.5 CaCl₂, 1.5 MgSO₄, 25 NaHCO₃, 1.2 KH₂PO₄, 11 glucose)
- Phenylephrine (PE) hydrochloride
- Potassium chloride (KCl)
- Organ bath system with isometric force transducers
- 95% O₂ / 5% CO₂ gas mixture

Methodology:

- Tissue Preparation: Euthanize the rat by an approved method (e.g., CO₂ asphyxiation followed by cervical dislocation).[17] Immediately excise the thoracic aorta and place it in ice-cold Krebs-Henseleit solution. Carefully clean away adhering connective tissue and cut the aorta into 3-4 mm rings.[15][17]
- Mounting: Suspend each aortic ring between two stainless steel hooks in an organ bath chamber filled with 20 mL of Krebs-Henseleit solution, maintained at 37°C and continuously bubbled with 95% O₂ / 5% CO₂.[15]
- Equilibration: Allow the rings to equilibrate for 60-90 minutes under a resting tension of 1.5-2.0 grams.[17] Replace the buffer every 15-20 minutes.
- Viability and Normalization: Contract the rings with a maximal dose of KCl (e.g., 80 mM) to ensure viability and to establish a reference maximum contraction. Wash the rings and allow them to return to baseline tension.
- First Cumulative Dose-Response Curve (CRC1): Add phenylephrine to the organ bath in a cumulative manner (e.g., 10⁻⁹ M to 10⁻⁵ M), allowing the response to stabilize at each concentration.[15] This generates the initial dose-response curve.
- Desensitization Period: After reaching the maximal response, wash out the phenylephrine by repeatedly changing the buffer over a 60-minute period. Then, re-incubate the tissue with a desensitizing concentration of phenylephrine (e.g., 1 μM) for a fixed period (e.g., 60-120 minutes).
- Washout: Perform another washout period (e.g., 60 minutes) to remove the desensitizing agent.
- Second Cumulative Dose-Response Curve (CRC2): Repeat the cumulative addition of phenylephrine to generate a second dose-response curve.[14]
- Data Analysis: Compare the maximal effect (E_{max}) and the EC₅₀ (concentration producing 50% of maximal response) between CRC1 and CRC2. A decrease in E_{max} and/or an increase in EC₅₀ for CRC2 indicates tachyphylaxis.

Protocol 2: Visualizing α 1-AR Internalization using Immunofluorescence

Objective: To visually track the translocation of α 1-AR from the cell membrane to intracellular compartments following agonist stimulation.

Materials:

- HEK293 or other suitable cells stably expressing a tagged α 1-AR (e.g., HA-tag or GFP-tag)
- Glass coverslips coated with poly-L-lysine
- Phenylephrine
- Paraformaldehyde (PFA) 4% in PBS
- Permeabilization buffer (e.g., 0.1% Triton X-100 in PBS)
- Blocking buffer (e.g., 5% Bovine Serum Albumin in PBS)
- Primary antibody (e.g., anti-HA) and fluorescently labeled secondary antibody
- DAPI for nuclear staining
- Fluorescence microscope

Methodology:

- Cell Culture: Plate the α 1-AR expressing cells onto sterile glass coverslips in a 24-well plate and grow to ~70% confluency.
- Stimulation: Treat the cells with phenylephrine (e.g., 10 μ M) or vehicle (control) for various time points (e.g., 0, 5, 15, 30, 60 minutes) at 37°C.
- Fixation: Quickly wash the cells with ice-cold PBS and fix them with 4% PFA for 15 minutes at room temperature.

- **Permeabilization:** Wash with PBS and permeabilize the cell membranes with permeabilization buffer for 10 minutes. This step is crucial for allowing antibodies to access intracellular antigens.
- **Blocking:** Wash and block non-specific antibody binding by incubating with blocking buffer for 1 hour.
- **Antibody Staining:** Incubate with the primary antibody diluted in blocking buffer for 1-2 hours. Wash three times with PBS. Then, incubate with the fluorescently labeled secondary antibody (and DAPI) for 1 hour in the dark.
- **Mounting and Imaging:** Wash three times with PBS. Mount the coverslips onto microscope slides using an anti-fade mounting medium.
- **Analysis:** Visualize the cells using a fluorescence or confocal microscope. In unstimulated cells, fluorescence should be primarily at the cell periphery (membrane). After phenylephrine stimulation, the appearance of punctate fluorescent vesicles within the cytoplasm indicates receptor internalization.^{[18][19]}

Visualizations

Signaling Pathway of Phenylephrine-Induced Tachyphylaxis

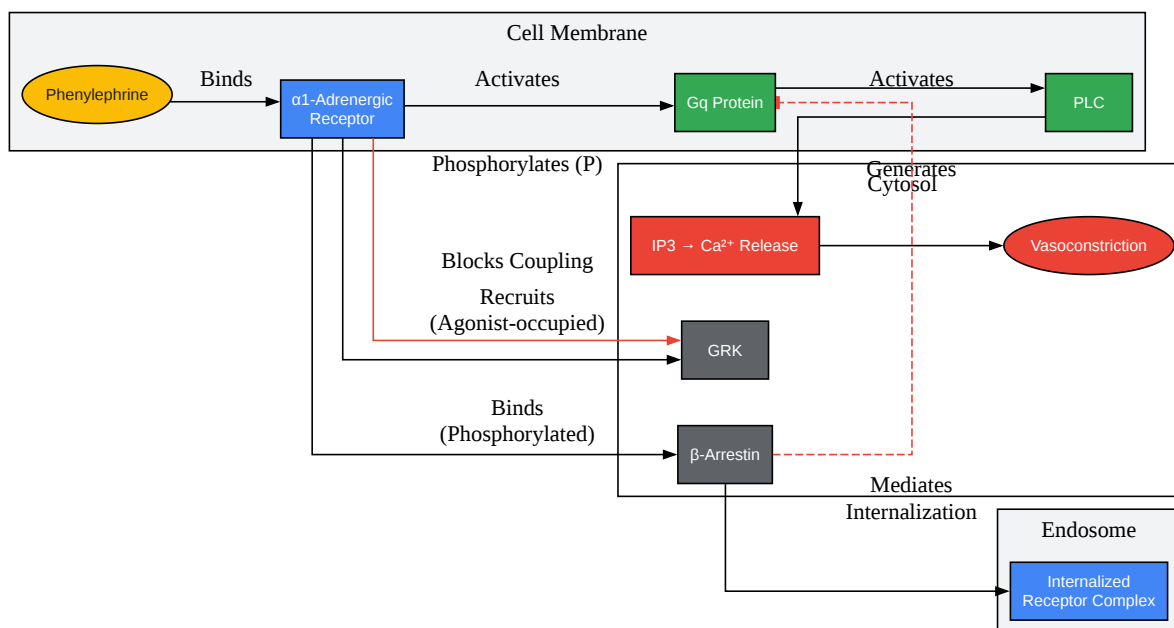

[Click to download full resolution via product page](#)

Caption: Mechanism of $\alpha 1$ -AR desensitization and internalization.

Experimental Workflow for Tachyphylaxis Assessment

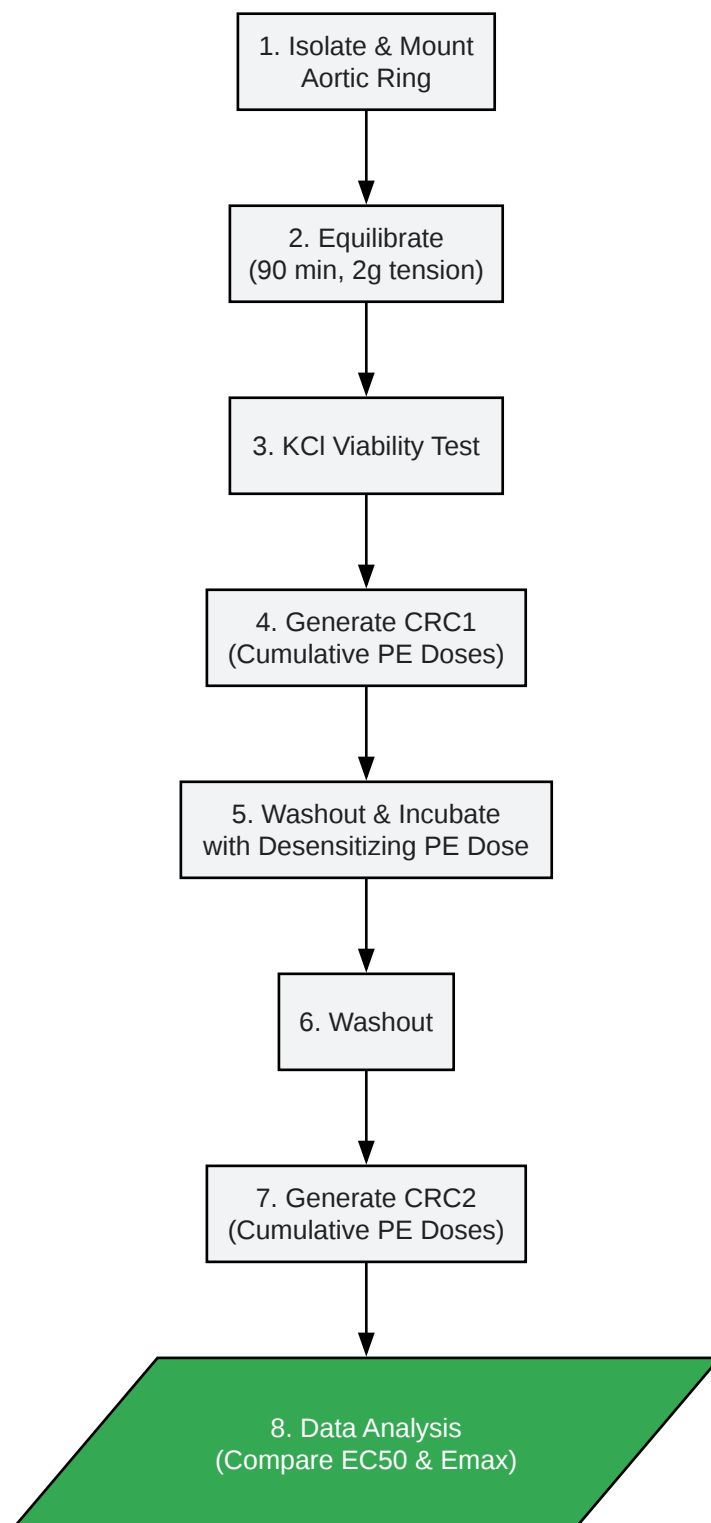

[Click to download full resolution via product page](#)

Caption: Workflow for assessing tachyphylaxis in isolated aorta.

Troubleshooting Logic for Diminished Response

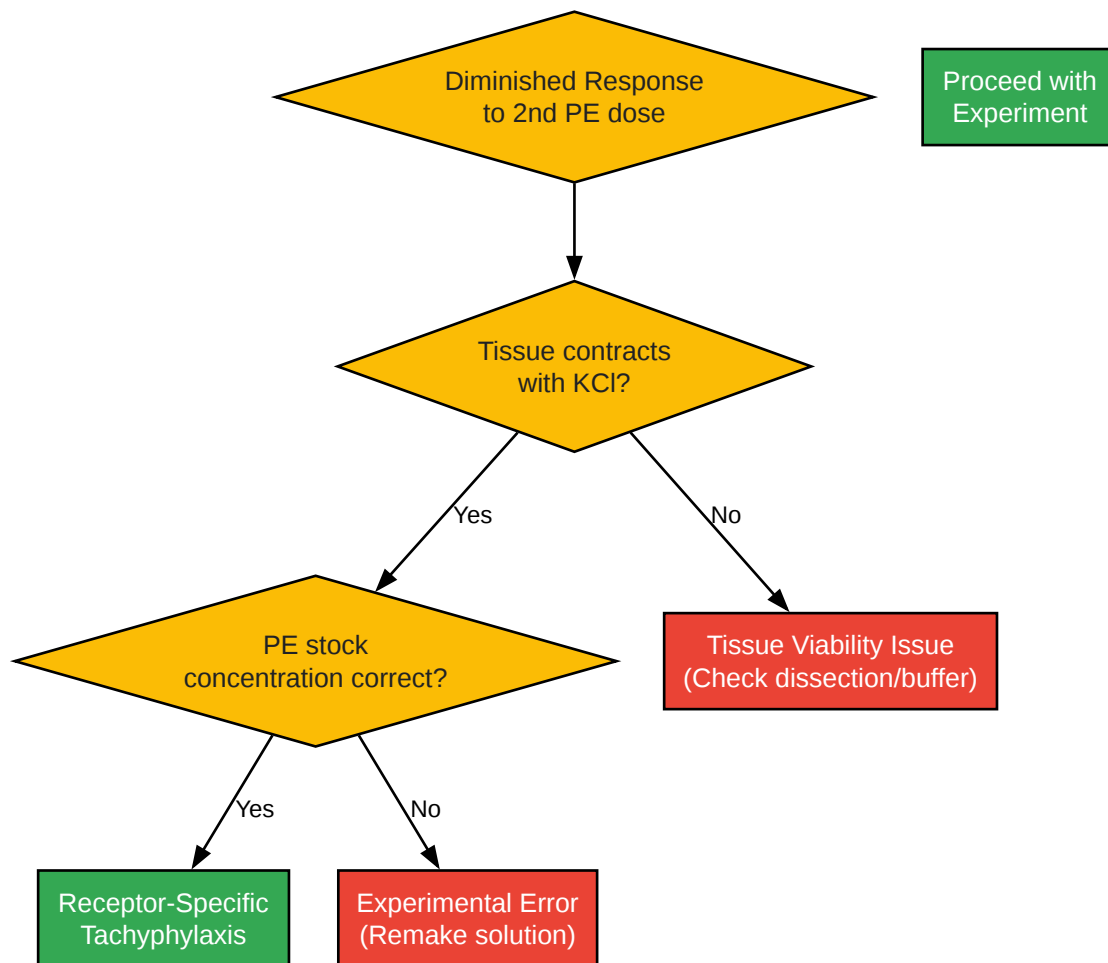

[Click to download full resolution via product page](#)

Caption: Troubleshooting logic for loss of phenylephrine response.

Need Custom Synthesis?

BenchChem offers custom synthesis for rare earth carbides and specific isotopic labeling.

Email: info@benchchem.com or [Request Quote Online](#).

References

- 1. [Adrenoceptor Desensitization: Current Understanding of Mechanisms - PMC](#) [pmc.ncbi.nlm.nih.gov]

- [2. Desensitization of alpha-1 adrenergic receptor-mediated vascular smooth muscle contraction - PubMed \[pubmed.ncbi.nlm.nih.gov\]](#)
- [3. \$\beta\$ -Arrestins: Structure, Function, Physiology, and Pharmacological Perspectives - PMC \[pmc.ncbi.nlm.nih.gov\]](#)
- [4. GPCR signaling via \$\beta\$ -arrestin-dependent mechanisms - PMC \[pmc.ncbi.nlm.nih.gov\]](#)
- [5. taylorandfrancis.com \[taylorandfrancis.com\]](#)
- [6. Research Portal \[researchdiscovery.drexel.edu\]](#)
- [7. \$\beta\$ -Arrestins specifically constrain \$\beta\$ 2-adrenergic receptor signaling and function in airway smooth muscle - PMC \[pmc.ncbi.nlm.nih.gov\]](#)
- [8. Desensitization of alpha-1 adrenergic receptor mediated smooth muscle contraction in aorta from endotoxic rats - PubMed \[pubmed.ncbi.nlm.nih.gov\]](#)
- [9. researchgate.net \[researchgate.net\]](#)
- [10. anesth-pain-med.org \[anesth-pain-med.org\]](#)
- [11. accessdata.fda.gov \[accessdata.fda.gov\]](#)
- [12. journals.physiology.org \[journals.physiology.org\]](#)
- [13. Small-Molecule G Protein–Coupled Receptor Kinase Inhibitors Attenuate G Protein–Coupled Receptor Kinase 2–Mediated Desensitization of Vasoconstrictor-Induced Arterial Contractions - PMC \[pmc.ncbi.nlm.nih.gov\]](#)
- [14. Activation of \$\alpha\$ 1A-adrenoceptors desensitizes the rat aorta response to phenylephrine through a neuronal NOS pathway, a mechanism lost with ageing - PMC \[pmc.ncbi.nlm.nih.gov\]](#)
- [15. KoreaMed Synapse \[synapse.koreamed.org\]](#)
- [16. Effect of phenylephrine and endothelium on vasomotion in rat aorta involves potassium uptake - PMC \[pmc.ncbi.nlm.nih.gov\]](#)
- [17. e-century.us \[e-century.us\]](#)
- [18. Visualizing the endocytosis of phenylephrine in living cells by quantum dot-based tracking - PubMed \[pubmed.ncbi.nlm.nih.gov\]](#)
- [19. researchgate.net \[researchgate.net\]](#)
- [To cite this document: BenchChem. \[How to prevent tachyphylaxis with repeated phenylephrine administration\]. BenchChem, \[2026\]. \[Online PDF\]. Available at: \[https://www.benchchem.com/product/b12792407/docs#how-to-prevent-tachyphylaxis-with-repeated-phenylephrine-administration\]](#)

Disclaimer & Data Validity:

The information provided in this document is for Research Use Only (RUO) and is strictly not intended for diagnostic or therapeutic procedures. While BenchChem strives to provide accurate protocols, we make no warranties, express or implied, regarding the fitness of this product for every specific experimental setup.

Technical Support: The protocols provided are for reference purposes. Unsure if this reagent suits your experiment?

Need Industrial/Bulk Grade? [Request Custom Synthesis Quote](#)

BenchChem

Our mission is to be the trusted global source of essential and advanced chemicals, empowering scientists and researchers to drive progress in science and industry.

Contact

Address: 3281 E Guasti Rd
Ontario, CA 91761, United States
Phone: (601) 213-4426
Email: info@benchchem.com

[Contact our Ph.D. Support Team for a compatibility check](#)