

Technical Support Center: Stabilizing 4-Bromofuran-2-one in Synthetic Applications

Author: BenchChem Technical Support Team. **Date:** May 2026

Compound of Interest

Compound Name: 4-Bromofuran-2-one

CAS No.: 56634-50-5

Cat. No.: B1279700

[Get Quote](#)

Welcome to the dedicated technical support center for **4-Bromofuran-2-one**. This resource is tailored for researchers, medicinal chemists, and process development scientists who utilize this versatile building block. **4-Bromofuran-2-one**, a member of the butenolide family, is a highly reactive intermediate, and its successful application hinges on understanding and mitigating its potential decomposition pathways. This guide provides in-depth, field-proven insights into the stability of **4-Bromofuran-2-one**, troubleshooting common issues, and ensuring the integrity of your reactions.

Part 1: Frequently Asked Questions (FAQs) on the Stability of 4-Bromofuran-2-one

Q1: What are the primary factors that contribute to the decomposition of **4-Bromofuran-2-one**?

A1: The decomposition of **4-Bromofuran-2-one** is primarily driven by its inherent chemical structure. The key factors are:

- Ring Strain: The five-membered lactone ring possesses some degree of ring strain, making it susceptible to ring-opening reactions.[1]

- **α,β -Unsaturated System:** The conjugated double bond in the lactone ring makes it an active Michael acceptor, prone to nucleophilic attack.
- **Electron-Withdrawing Bromine:** The bromine atom is an electron-withdrawing group that influences the electrophilicity of the furanone ring.[2]
- **Lactone Functionality:** The ester linkage in the lactone is susceptible to hydrolysis under both acidic and basic conditions.

Q2: What are the recommended storage conditions for **4-Bromofuran-2-one**?

A2: Proper storage is critical to maintain the purity and stability of **4-Bromofuran-2-one**. While some suppliers suggest room temperature storage for short periods, long-term stability is best achieved under controlled conditions.[3] For analogous brominated and lactone-containing compounds, the following is recommended:

Parameter	Recommended Condition	Rationale
Temperature	2°C to 8°C (Refrigerated)	Minimizes the rate of potential thermal decomposition.
Atmosphere	Under an inert gas (e.g., Argon, Nitrogen)	The furanone ring can be sensitive to oxidation.
Moisture	In a dry, tightly sealed container	The lactone is susceptible to hydrolysis.
Light	In an amber vial or protected from light	Brominated compounds can be light-sensitive and undergo photodecomposition.

Q3: What are the visible signs of **4-Bromofuran-2-one** decomposition?

A3: Decomposition can often be visually observed as a change in the physical appearance of the compound. This may include:

- **Color Change:** A noticeable darkening or change from a pale yellow or off-white solid to a brown or black tar-like substance.

- **Formation of Insoluble Material:** The appearance of solid precipitates in a solution of the compound.
- **Gas Evolution:** In some cases, decomposition may be accompanied by the release of gases.

Analytical techniques such as TLC, NMR, and LC-MS should be used to confirm decomposition and identify byproducts.

Part 2: Troubleshooting Decomposition During Reactions

This section provides troubleshooting guidance for common reaction scenarios where the decomposition of **4-Bromofuran-2-one** is a significant concern.

Scenario 1: Decomposition under Basic Conditions (e.g., in the presence of amines, hydroxides, or organometallics)

Observed Problem: Low yield of the desired product, formation of a complex mixture of byproducts, or complete consumption of the starting material with no desired product formation when using basic reagents.

Underlying Cause & Mechanism:

4-Bromofuran-2-one is highly susceptible to degradation in the presence of bases. The primary decomposition pathways include:

- **Ring Opening via Nucleophilic Acyl Substitution:** The lactone is an ester and will be readily attacked by nucleophilic bases at the carbonyl carbon, leading to ring opening.
- **Michael Addition:** The α,β -unsaturated system is a prime target for nucleophilic addition.
- **Polymerization:** The furan ring itself can be prone to acid- or base-catalyzed polymerization, especially at elevated temperatures.^{[4][5]}

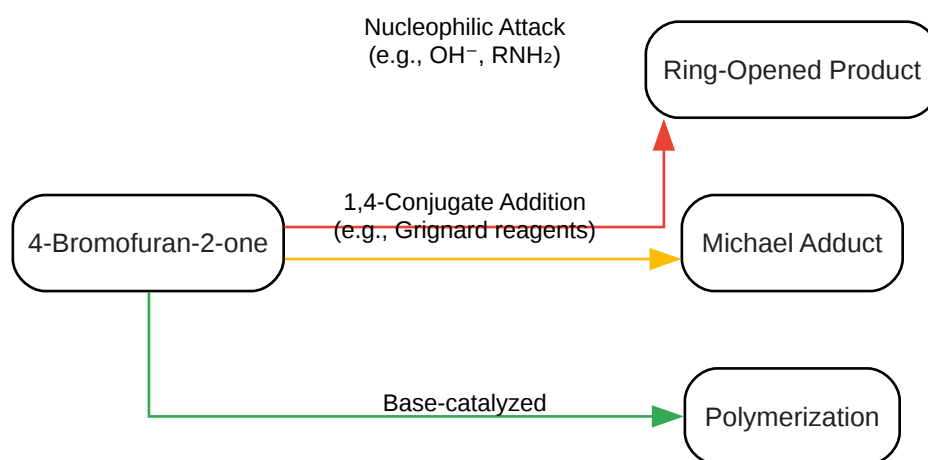

[Click to download full resolution via product page](#)

Caption: Decomposition pathways of **4-Bromofuran-2-one** under basic conditions.

Preventative Measures & Protocols:

- Choice of Base: Opt for weaker, non-nucleophilic bases where possible. If a strong nucleophilic base is required, use stoichiometric amounts and maintain low temperatures.
- Temperature Control: Perform the reaction at low temperatures (e.g., -78 °C to 0 °C) to minimize side reactions.
- Slow Addition: Add the base or nucleophile slowly to a solution of **4-Bromofuran-2-one** to maintain a low instantaneous concentration of the nucleophile.
- Inverse Addition: In some cases, adding the **4-Bromofuran-2-one** solution to the base can be beneficial.
- Anhydrous Conditions: Ensure strictly anhydrous conditions, as water can facilitate hydrolysis.

Experimental Protocol: Nucleophilic Addition of an Amine

- Dissolve **4-Bromofuran-2-one** (1.0 eq) in a suitable anhydrous solvent (e.g., THF, DCM) and cool the solution to -20 °C under an inert atmosphere.

- In a separate flask, dissolve the amine nucleophile (1.0-1.2 eq) in the same anhydrous solvent.
- Add the amine solution dropwise to the cooled solution of **4-Bromofuran-2-one** over 30-60 minutes.
- Monitor the reaction by TLC.
- Upon completion, quench the reaction with a mild acid (e.g., saturated aqueous NH_4Cl) at low temperature.

Scenario 2: Decomposition under Acidic Conditions (e.g., in the presence of Lewis or Brønsted acids)

Observed Problem: Formation of dark, insoluble polymeric material, and low recovery of desired product, particularly at elevated temperatures.

Underlying Cause & Mechanism:

Furan rings are known to be sensitive to strong acids, which can lead to polymerization and ring-opening.^{[6][7]} The likely decomposition pathways include:

- Acid-Catalyzed Polymerization: Protonation of the furanone can initiate a cascade of electrophilic aromatic substitution-type reactions, leading to polymer formation.
- Ring Opening: In the presence of water, acid can catalyze the hydrolysis of the lactone.

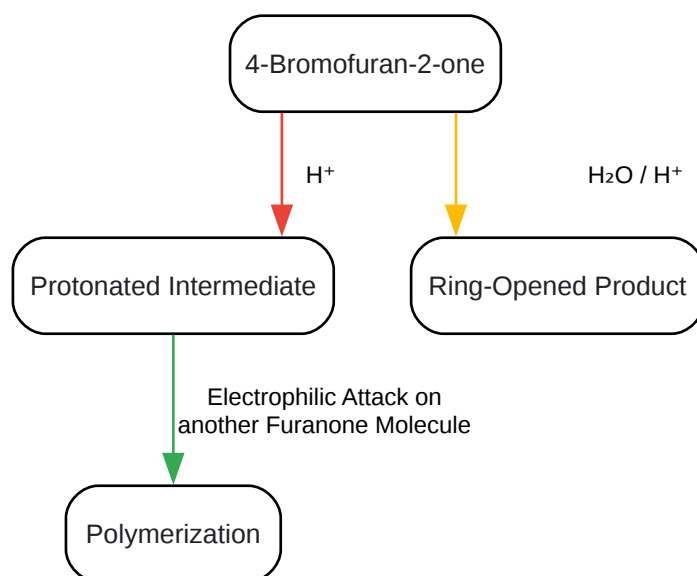

[Click to download full resolution via product page](#)

Caption: Decomposition pathways of **4-Bromofuran-2-one** under acidic conditions.

Preventative Measures & Protocols:

- Choice of Acid: Use the mildest acid catalyst that is effective for the desired transformation.
- Control of Stoichiometry: Use catalytic amounts of acid whenever possible.
- Temperature Management: Avoid high reaction temperatures. If heating is necessary, do so cautiously and for the minimum time required.
- Anhydrous Conditions: For reactions that do not require water, ensure all reagents and solvents are anhydrous to prevent hydrolysis.

Scenario 3: Thermal Decomposition

Observed Problem: Decomposition of the compound upon heating, even in the absence of strong acids or bases.

Underlying Cause & Mechanism:

While specific data for **4-Bromofuran-2-one** is limited, γ -lactones can undergo thermal decomposition.^[8] Potential pathways include:

- Decarbonylation or Decarboxylation: At high temperatures, the lactone ring may fragment, losing carbon monoxide or carbon dioxide.[9]
- Isomerization: The double bond may migrate under thermal stress.

Preventative Measures:

- Reaction Temperature: Keep reaction temperatures as low as possible.
- Reaction Time: Minimize reaction times at elevated temperatures.
- Purification Method: Avoid high-temperature distillation for purification. Opt for chromatography or recrystallization at lower temperatures.

Scenario 4: Photochemical Decomposition

Observed Problem: Degradation of the material upon exposure to light, especially UV light.

Underlying Cause & Mechanism:

Brominated organic compounds can be susceptible to photodecomposition, often involving the homolytic cleavage of the carbon-bromine bond to form radical intermediates. These radicals can then participate in a variety of subsequent reactions, leading to product degradation.

Preventative Measures:

- Protect from Light: Conduct reactions in flasks wrapped in aluminum foil or in amber glassware.
- Storage: Store the compound in the dark.

Part 3: Data Summary and Analytical Considerations

Table for Troubleshooting Reaction Conditions:

Observation	Potential Cause	Suggested Action
Reaction turns dark/black	Acid- or base-catalyzed polymerization	Lower reaction temperature, use a milder acid/base, ensure anhydrous conditions.
Multiple spots on TLC, streaking	Decomposition into multiple byproducts	Check pH of the reaction, lower temperature, reduce reaction time.
Low mass balance after workup	Formation of water-soluble ring-opened products	Extract the aqueous layer with a more polar organic solvent, or perform a workup under neutral conditions.
Product decomposes on silica gel	Acidic nature of silica gel	Neutralize the silica gel with a small amount of triethylamine in the eluent, or use an alternative stationary phase like alumina.

Analytical Notes:

- NMR Spectroscopy: Decomposition can be monitored by ^1H NMR by observing the disappearance of the characteristic peaks for **4-Bromofuran-2-one** and the appearance of new, often broad, signals in the aliphatic or aromatic regions, which may indicate polymerization.[10]
- Mass Spectrometry: LC-MS is a powerful tool to identify potential decomposition products by their mass-to-charge ratio.

References

- Li, X., et al. (2016). Effects of water and alcohols on the polymerization of furan during its acid-catalyzed conversion into benzofuran. RSC Advances, 6(46), 40069-40076.
- L'Her, M., et al. (2022).
- Frontier, A. (2026). How to Troubleshoot a Reaction. University of Rochester Department of Chemistry. Retrieved from [[Link](#)]

- How do α,β -unsaturated acids undergo decarboxylation? (2019, May 21). Chemistry Stack Exchange. Retrieved from [[Link](#)]
- Gandini, A. (2017). The behaviour of furan derivatives in polymerization reactions. *Polymer Chemistry*, 8(23), 3536-3552.
- Frontier, A. (n.d.). How To: Troubleshoot a Reaction. University of Rochester Department of Chemistry. Retrieved from [[Link](#)]
- Organic Chemistry Portal. (n.d.). Synthesis of 3(2H)-furanones. Retrieved from [[Link](#)]
- Al-Mughanam, T., et al. (2020). Gamma-valerolactone (GVL) as a biofuel: Investigation of GVL thermal decomposition and GVL + OH reaction. KAUST Repository.
- Dumur, F. (2021).
- Chen, C. H., et al. (2016). Development of a Practical and Scalable Synthetic Route for DBPR112: A Clinical Candidate for the Treatment of Non-Small Cell Lung Cancer. *Organic Process Research & Development*, 20(2), 373-383.
- Ren, Y., et al. (2015). Effect of Brominated Furanones on the Formation of Biofilm by *Escherichia coli* on Polyvinyl Chloride Materials. *Journal of Biomaterials and Tissue Engineering*, 5(8), 643-649.
- Kolykhalov, D. A., et al. (2024). The Stability Challenge of Furanic Platform Chemicals in Acidic and Basic Conditions. *ChemSusChem*.
- Kolykhalov, D. A., et al. (2024). The Stability Challenge of Furanic Platform Chemicals in Acidic and Basic Conditions. *ChemSusChem*, e202401849.
- Ito, H., et al. (2019). Ring-expanding and ring-opening transformations of benzofurans and indoles with introducing heteroatoms.
- Bock, H., et al. (1983). Thermal decomposition of methylated γ -thiobutyrolactones: a photoelectron spectroscopic study. *Journal of the Chemical Society, Perkin Transactions 2*, (1), 27-32.
- Kolykhalov, D. A., et al. (2024). The Stability Challenge of Furanic Platform Chemicals in Acidic and Basic Conditions.
- What is the mechanism of decarboxylation of β,γ -unsaturated carboxylic acids? (2021, October 29). Chemistry Stack Exchange. Retrieved from [[Link](#)]
- Ring opening reactions of furans. (n.d.). ResearchGate. Retrieved from [[Link](#)]
- Angi, D., et al. (2019).

- He, J., et al. (2018). Versatile Butenolide Syntheses via a Structure-Oriented C–H Activation Reaction. *Journal of the American Chemical Society*, 140(40), 12816-12825.
- Edison, A. S., et al. (2011). NMR-spectroscopic analysis of mixtures: from structure to function. *Current opinion in chemical biology*, 15(1), 34-41.
- Ren, Y., et al. (2015). Effect of Brominated Furanones on the Formation of Biofilm by *Escherichia coli* on Polyvinyl Chloride Materials. *Journal of Biomaterials and Tissue Engineering*, 5(8), 643-649.
- Reaction with the butenolide 1 q. (n.d.). ResearchGate. Retrieved from [[Link](#)]
- Zhang, Y., et al. (2015). Structures and biofilm inhibition activities of brominated furanones for *Escherichia coli* and *Pseudomonas aeruginosa*. *MedChemComm*, 6(3), 547-553.
- da Silva, R. R., et al. (2024). On the part that NMR should play in mass spectrometry metabolomics in natural products studies. *Frontiers in Molecular Biosciences*, 11, 1356877.
- Janssens, J. C., et al. (2008). Brominated Furanones Inhibit Biofilm Formation by *Salmonella enterica* Serovar Typhimurium. *Applied and Environmental Microbiology*, 74(21), 6639-6648.
- Ashenhurst, J. (2020, March 16). Electrocyclic Reactions. *Master Organic Chemistry*. Retrieved from [[Link](#)]
- Janssens, J. C., et al. (2008). Brominated furanones inhibit biofilm formation by *Salmonella enterica* serovar Typhimurium. *Applied and Environmental Microbiology*, 74(21), 6639-6648.
- Sarpong, R., et al. (2015). Proximity Effects in Nucleophilic Addition Reactions to Medium-Bridged Twisted Lactams: Remarkably Stable Tetrahedral Intermediates. *The Journal of organic chemistry*, 80(19), 9435-9447.
- Behr, J. B., et al. (2016). Nucleophilic reactions of ethyl (Z)-2-bromo-4,4,4-trifluorobut-2-enoate: One molecule – various heterocycles. *Journal of Fluorine Chemistry*, 189, 64-71.
- Spicer, R. A., et al. (2022). Problems, principles and progress in computational annotation of NMR metabolomics data. *TrAC Trends in Analytical Chemistry*, 157, 116742.
- Splendid Lab Pvt. Ltd. (n.d.). **4-Bromofuran-2-one**. Retrieved from [[Link](#)]
- Iovine, V., et al. (2018). Synthesis of Benzofuran-2-One Derivatives and Evaluation of Their Antioxidant Capacity by Comparing DPPH Assay and Cyclic Voltammetry. *Molecules*, 23(3), 706.

Need Custom Synthesis?

BenchChem offers custom synthesis for rare earth carbides and specific isotopic labeling.

Email: info@benchchem.com or [Request Quote Online](#).

Sources

- 1. Investigation of Lactones as Innovative Bio-Sourced Phase Change Materials for Latent Heat Storage - PMC [[pmc.ncbi.nlm.nih.gov](https://pubmed.ncbi.nlm.nih.gov)]
- 2. pdf.benchchem.com [pdf.benchchem.com]
- 3. calpaclab.com [calpaclab.com]
- 4. Effects of water and alcohols on the polymerization of furan during its acid-catalyzed conversion into benzofuran - RSC Advances (RSC Publishing) DOI:10.1039/C6RA04745A [pubs.rsc.org]
- 5. researchgate.net [researchgate.net]
- 6. researchgate.net [researchgate.net]
- 7. The Stability Challenge of Furanic Platform Chemicals in Acidic and Basic Conditions - PubMed [pubmed.ncbi.nlm.nih.gov]
- 8. DSpace [repository.kaust.edu.sa]
- 9. Thermal decomposition of methylated γ -thiobutyrolactones: a photoelectron spectroscopic study - Journal of the Chemical Society, Perkin Transactions 2 (RSC Publishing) [pubs.rsc.org]
- 10. NMR-spectroscopic analysis of mixtures: from structure to function - PMC [[pmc.ncbi.nlm.nih.gov](https://pubmed.ncbi.nlm.nih.gov)]
- To cite this document: BenchChem. [Technical Support Center: Stabilizing 4-Bromofuran-2-one in Synthetic Applications]. BenchChem, [2026]. [Online PDF]. Available at: [<https://www.benchchem.com/product/b1279700/docs#technical-support-center-stabilizing-4-bromofuran-2-one-in-synthetic-applications>]

Disclaimer & Data Validity:

The information provided in this document is for Research Use Only (RUO) and is strictly not intended for diagnostic or therapeutic procedures. While BenchChem strives to provide

accurate protocols, we make no warranties, express or implied, regarding the fitness of this product for every specific experimental setup.

Technical Support: The protocols provided are for reference purposes. Unsure if this reagent suits your experiment?

Need Industrial/Bulk Grade? [Request Custom Synthesis Quote](#)

BenchChem

Our mission is to be the trusted global source of essential and advanced chemicals, empowering scientists and researchers to drive progress in science and industry.

Contact

Address: 3281 E Guasti Rd

Ontario, CA 91761, United States

Phone: (601) 213-4426

Email: info@benchchem.com

[Contact our Ph.D. Support Team for a compatibility check](#)