

Synthesis and characterization of 1-(2-Chloroethoxy)-3-methoxybenzene

Author: BenchChem Technical Support Team. **Date:** May 2026

Compound of Interest

Compound Name: 1-(2-Chloroethoxy)-3-methoxybenzene

CAS No.: 102877-31-6

Cat. No.: B1279993

[Get Quote](#)

Technical Guide: Synthesis and Characterization of **1-(2-Chloroethoxy)-3-methoxybenzene**

Part 1: Executive Summary

1-(2-Chloroethoxy)-3-methoxybenzene (CAS: 14804-51-4), also known as 3-(2-chloroethoxy)anisole, is a critical bifunctional building block in medicinal chemistry. Structurally, it consists of a benzene ring substituted meta- to each other with a methoxy group and a 2-chloroethoxy moiety.

This molecule serves as a "lipophilic linker" intermediate. The chloroethyl group acts as an electrophilic handle, readily undergoing nucleophilic substitution with secondary amines to form phenoxyethylamine motifs, a pharmacophore ubiquitous in GPCR ligands (e.g., dopamine and serotonin receptor antagonists) and cardiovascular agents. The methoxy group provides metabolic stability or serves as a latent phenol (via demethylation) for further diversification.

This guide details the optimized synthesis, purification, and characterization of this compound, prioritizing scalability and chemical purity.

Part 2: Retrosynthetic Analysis & Strategy

To design the most robust synthetic route, we apply a retrosynthetic disconnection at the ether oxygen of the chloroethoxy side chain.

Strategic Logic:

- Disconnection: The C(sp³)-O bond is the most logical disconnection, leading to 3-methoxyphenol (nucleophile) and a 1,2-dihaloethane derivative (electrophile).
- Electrophile Selection:
 - Option A (1,2-Dichloroethane): Cheap but requires large excess to prevent dimerization (bis-phenoxy formation) and has lower reactivity.
 - Option B (1-Bromo-2-chloroethane): Preferred. The bromide is a significantly better leaving group than chloride (). This allows for selective mono-alkylation at the bromide site under mild conditions, leaving the chloride intact for the next synthetic step.
- Nucleophile: 3-Methoxyphenol (Resorcinol monomethyl ether) is commercially available and inexpensive.

Visualized Retrosynthesis:

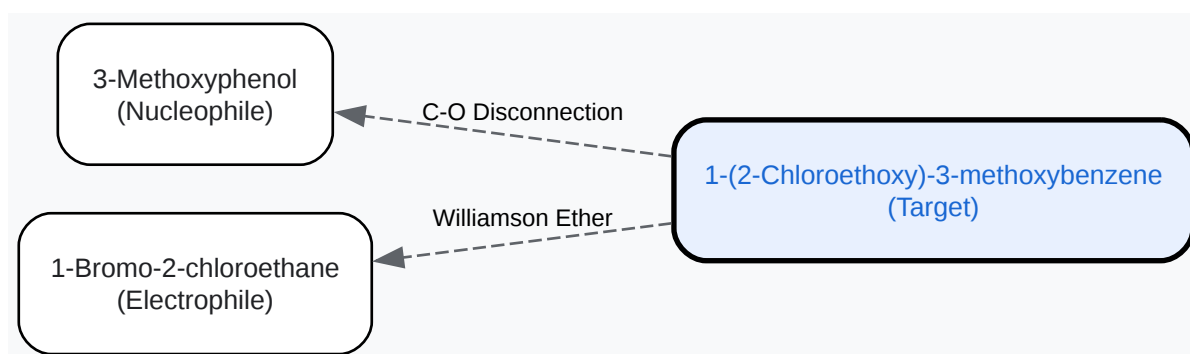

[Click to download full resolution via product page](#)

Caption: Retrosynthetic disconnection revealing the convergent assembly from 3-methoxyphenol and 1-bromo-2-chloroethane.

Part 3: Experimental Protocols

Method A: Selective Alkylation (The "Gold Standard" Route)

Rationale: This method utilizes the reactivity difference between bromide and chloride to achieve high selectivity. Potassium carbonate (

) is chosen as the base over NaOH to minimize hydrolysis of the alkyl halide and prevent polymerization. Acetonitrile (ACN) or Acetone are preferred polar aprotic solvents.

Materials:

- 3-Methoxyphenol (1.0 equiv)
- 1-Bromo-2-chloroethane (1.5 equiv)
- Potassium Carbonate (), anhydrous (2.0 equiv)
- Potassium Iodide () (0.1 equiv) - Catalyst (Finkelstein condition)
- Solvent: Acetonitrile (ACN) or Acetone (Reagent Grade)

Step-by-Step Protocol:

- Setup: Oven-dry a 250 mL round-bottom flask (RBF) equipped with a magnetic stir bar and a reflux condenser. Flush with nitrogen ().
- Solvation: Add 3-methoxyphenol (12.4 g, 100 mmol) and Acetonitrile (100 mL) to the flask. Stir until dissolved.
- Deprotonation: Add anhydrous

(27.6 g, 200 mmol) in a single portion. The suspension will turn slightly opaque. Stir at Room Temperature (RT) for 15 minutes to initiate phenoxide formation.

- Addition: Add 1-bromo-2-chloroethane (21.5 g, 12.5 mL, 150 mmol) followed by KI (1.66 g, 10 mmol).
 - Note: KI acts as a catalyst by converting the alkyl bromide to the more reactive alkyl iodide in situ (Finkelstein reaction), accelerating the substitution.
- Reflux: Heat the reaction mixture to reflux () for 12–16 hours.
 - Monitoring: Monitor by TLC (Hexane:EtOAc 8:2). The starting phenol () should disappear, and a new less polar spot () should appear.
- Workup:
 - Cool the mixture to RT.
 - Filter off the inorganic salts (, , excess) through a Celite pad. Rinse the pad with acetone.
 - Concentrate the filtrate under reduced pressure (Rotavap) to obtain a crude oil.
- Purification:
 - Dissolve the residue in Ethyl Acetate (100 mL) and wash with 1M NaOH (2 x 50 mL) to remove any unreacted phenol (critical for purity).
 - Wash with Brine (50 mL), dry over anhydrous

, and concentrate.

- Optional: If high purity is required, distill under high vacuum (approx.

at 5 mmHg) or perform flash column chromatography (SiO₂, 5-10% EtOAc in Hexanes).

Yield: Typically 85–92% as a colorless to pale yellow oil.

Reaction Scheme Visualization:

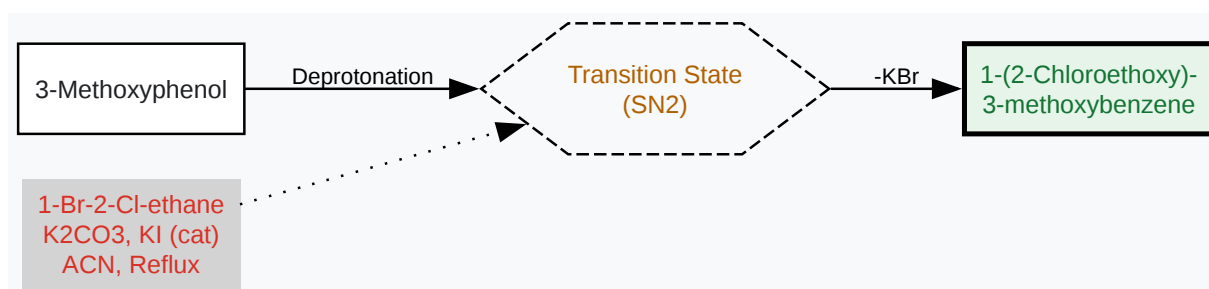

[Click to download full resolution via product page](#)

Caption: One-pot alkylation workflow using phase-transfer catalysis principles.

Part 4: Characterization & Data Analysis

Validation of the structure requires confirming the presence of the ethoxy linker and the specific substitution pattern on the benzene ring.

Nuclear Magnetic Resonance (NMR) Spectroscopy

- NMR (400 MHz,

):

- 7.18 (t, J=8.2 Hz, 1H): Aromatic proton at position 5 (meta to both oxygens).
- 6.45 – 6.55 (m, 3H): Aromatic protons at positions 2, 4, and 6. The proton at position 2 is often a singlet-like triplet due to shielding by two oxygen atoms.
- 4.23 (t, J=6.0 Hz, 2H):

protons. Deshielded by the phenoxy oxygen.

- 3.81 (t, J=6.0 Hz, 2H):
protons. Distinct triplet upfield from the ether linkage.
- 3.79 (s, 3H):
methoxy protons. (May overlap slightly with the chloroethyl triplet depending on resolution).
- NMR (100 MHz,
):
 - Aromatic C:
160.8 (C-1), 159.5 (C-3), 129.9 (C-5), 107.2, 106.8, 101.5 (C-2, C-4, C-6).
 - Aliphatic C:
67.8 (
, 55.3 (
, 41.8 (
).

Infrared Spectroscopy (FT-IR)

- 3000–2850
: C-H stretching (aliphatic and aromatic).
- 1590, 1490
: C=C aromatic ring skeletal vibrations.
- 1260, 1150
: C-O-C asymmetric stretching (Strong ether bands).
- 750, 690

: C-Cl stretch and aromatic out-of-plane bending (meta-substitution pattern).

Mass Spectrometry (GC-MS)

- Molecular Ion (): m/z 186 (for) and 188 (for) in a 3:1 ratio, characteristic of a monochlorinated compound.
- Base Peak: Often m/z 123 (), corresponding to the loss of the chloroethyl group (formation of the methoxyphenol radical cation).

Part 5: Process Optimization & Troubleshooting

| Issue | Probable Cause | Corrective Action |
|------------------------------|--------------------------|---|
| Low Yield | Incomplete conversion | Increase reaction time or add 0.1 equiv more KI. Ensure is finely ground/anhydrous. |
| Bis-alkylation | Dimerization of phenol | Unlikely with 1-bromo-2-chloroethane. If using 1,2-dichloroethane, increase electrophile excess to 5-10 equiv. |
| Elimination Product | Formation of vinyl ether | Avoid strong bases (NaOH/KOH) at high temps. Stick to . Keep temp .[1] |
| Starting Material in Product | Poor workup | The NaOH wash in step 7 is critical. Phenols are acidic and will move to the aqueous layer at pH 14; the ether product remains organic. |

Part 6: Safety & Handling (MSDS Highlights)

- Hazards:
 - 1-Bromo-2-chloroethane: Potential alkylating agent. Suspected carcinogen. Handle in a fume hood.
 - Product: Irritant to eyes, skin, and respiratory system.
- Storage: Store in a cool, dry place under inert atmosphere (). Stable at room temperature but avoid prolonged exposure to light.

- Disposal: Quench excess alkyl halides with aqueous ammonia or thiosulfate before disposal.

References

- Vogel, A. I. (1989). Vogel's Textbook of Practical Organic Chemistry (5th ed.). Longman Scientific & Technical. (Standard reference for Williamson Ether Synthesis protocols).
- Greene, T. W., & Wuts, P. G. M. (2014). Greene's Protective Groups in Organic Synthesis. John Wiley & Sons.
- PubChem Database. (2024). Compound Summary for CID 89689: **1-(2-Chloroethoxy)-3-methoxybenzene**. National Center for Biotechnology Information. [[Link](#)]

Need Custom Synthesis?

BenchChem offers custom synthesis for rare earth carbides and specific isotopic labeling.

Email: info@benchchem.com or [Request Quote Online](#).

Sources

- 1. EP0067342A1 - Process for the preparation of 2-chloro-1,3-dimethoxybenzene - Google Patents [patents.google.com]
- To cite this document: BenchChem. [Synthesis and characterization of 1-(2-Chloroethoxy)-3-methoxybenzene]. BenchChem, [2026]. [Online PDF]. Available at: [<https://www.benchchem.com/product/b1279993/docs#synthesis-and-characterization-of-1-2-chloroethoxy-3-methoxybenzene>]

Disclaimer & Data Validity:

The information provided in this document is for Research Use Only (RUO) and is strictly not intended for diagnostic or therapeutic procedures. While BenchChem strives to provide accurate protocols, we make no warranties, express or implied, regarding the fitness of this product for every specific experimental setup.

Technical Support: The protocols provided are for reference purposes. Unsure if this reagent suits your experiment?

Need Industrial/Bulk Grade? [Request Custom Synthesis Quote](#)

BenchChem

Our mission is to be the trusted global source of essential and advanced chemicals, empowering scientists and researchers to drive progress in science and industry.

Contact

Address: 3281 E Guasti Rd

Ontario, CA 91761, United States

Phone: (601) 213-4426

Email: info@benchchem.com

[Contact our Ph.D. Support Team for a compatibility check](#)