

Introduction: The Isatin Scaffold and the Significance of Fluorination

Author: BenchChem Technical Support Team. **Date:** May 2026

Compound of Interest

Compound Name: 6-Fluoro-7-methylisatin

CAS No.: 57817-03-5

Cat. No.: B1279404

[Get Quote](#)

Isatin (1H-indole-2,3-dione) and its derivatives are a cornerstone class of heterocyclic compounds, revered in medicinal chemistry and organic synthesis for their versatile reactivity and broad spectrum of biological activities.[1] First isolated in 1841 through the oxidation of indigo, the isatin core is a privileged scaffold, meaning it can bind to multiple biological targets with high affinity.[2] This has led to the development of isatin-based compounds with anticancer, antiviral, antimicrobial, and anti-inflammatory properties.[3]

The unique chemical architecture of isatin, featuring a fused aromatic ring, a lactam moiety, and vicinal C2 and C3 carbonyl groups, provides multiple sites for chemical modification. This allows for the fine-tuning of its physicochemical and pharmacological properties. The introduction of fluorine atoms into organic molecules is a well-established strategy in drug design to enhance metabolic stability, binding affinity, and lipophilicity.[4] Consequently, fluorinated isatin derivatives are of significant interest to researchers.

This technical guide provides a comprehensive overview of the chemical properties of a specific derivative, **6-Fluoro-7-methylisatin**. We will delve into its synthesis, spectroscopic profile, predicted reactivity, and potential as a building block for novel therapeutic agents, providing field-proven insights and detailed experimental protocols for the research community.

PART 1: Physicochemical and Structural Properties

6-Fluoro-7-methylisatin is a solid organic compound whose structural identity and core properties are summarized below. While extensive experimental data is not publicly available for this specific analog, a combination of catalog information and computational predictions provides a reliable profile for research and handling purposes.

Property	Value	Source(s)
IUPAC Name	6-fluoro-7-methyl-1H-indole-2,3-dione	[5]
Synonyms	6-Fluoro-7-methylindoline-2,3-dione	[6]
CAS Number	57817-03-5	[6][7]
Molecular Formula	C ₉ H ₆ FNO ₂	[6][7]
Molecular Weight	179.15 g/mol	[6][7]
Monoisotopic Mass	179.03825 Da	[8]
Predicted Density	1.399 g/cm ³	[7]
Predicted pKa	8.87 ± 0.20	[6]
Predicted XLogP	1.2	[8]
Topological Polar Surface Area	46.2 Å ²	[6]
Hydrogen Bond Acceptor Count	3	[6]

PART 2: Synthesis of 6-Fluoro-7-methylisatin

The most established and versatile method for preparing substituted isatins from anilines is the Sandmeyer isatin synthesis.[9] This two-step procedure is the most logical and anticipated route for the gram-scale production of **6-Fluoro-7-methylisatin**, starting from the commercially available 3-fluoro-2-methylaniline.

2.1: The Sandmeyer Synthesis Pathway

The synthesis proceeds in two key stages:

- Formation of the Isonitrosoacetanilide Intermediate: The starting aniline (3-fluoro-2-methylaniline) is reacted with chloral hydrate and hydroxylamine hydrochloride. This forms the N-(3-fluoro-2-methylphenyl)-2-(hydroxyimino)acetamide intermediate.^{[2][9]}
- Acid-Catalyzed Cyclization: The intermediate is then treated with a strong acid, typically concentrated sulfuric acid, which catalyzes an intramolecular electrophilic substitution to yield the final isatin product upon heating.^{[10][11]}

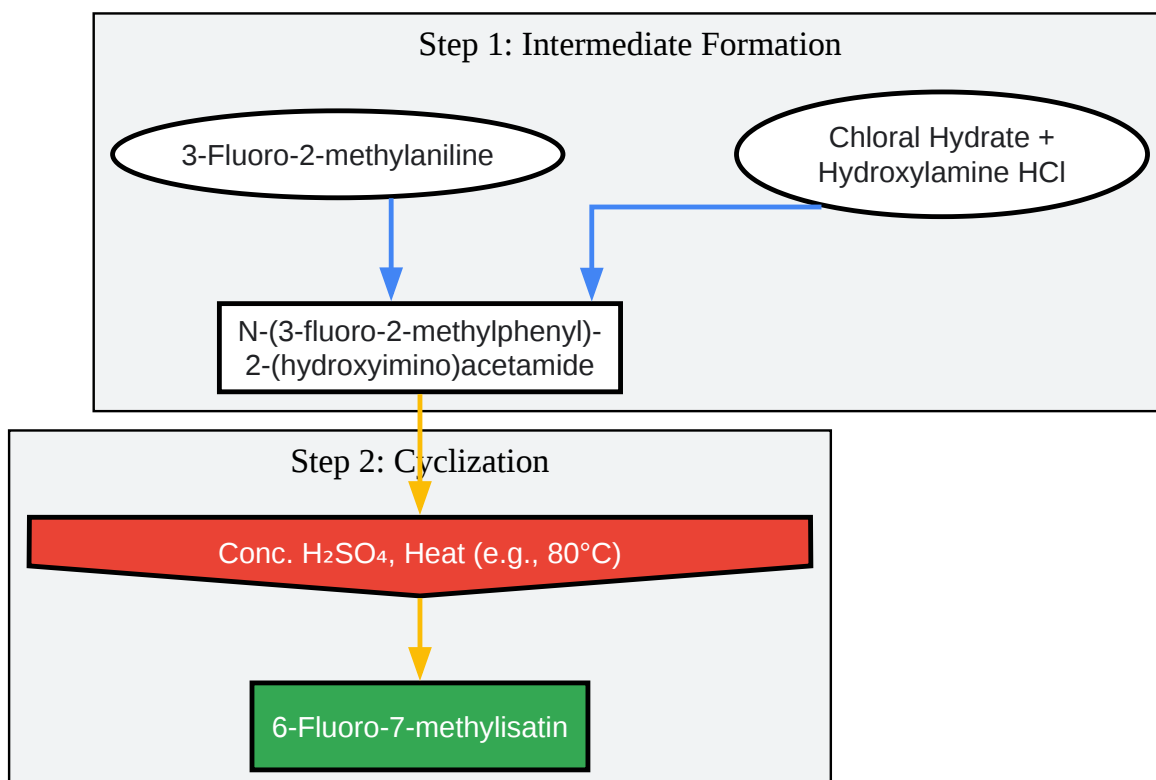

[Click to download full resolution via product page](#)

Caption: Proposed Sandmeyer synthesis workflow for **6-Fluoro-7-methylisatin**.

2.2: Detailed Experimental Protocol (Sandmeyer Synthesis)

This protocol is adapted from established procedures for analogous fluorinated isatins.^{[10][11]} All operations should be performed in a well-ventilated fume hood with appropriate personal protective equipment.

Step 1: Synthesis of N-(3-fluoro-2-methylphenyl)-2-(hydroxyimino)acetamide

- **Reagent Preparation:** In a 1 L three-neck round-bottom flask equipped with a mechanical stirrer, thermometer, and dropping funnel, dissolve anhydrous sodium sulfate (e.g., 120 g) in deionized water (e.g., 500 mL).
- **Addition of Chloral Hydrate:** To this solution, add chloral hydrate (e.g., 0.15 mol) and stir until fully dissolved.
- **Aniline Solution:** In a separate beaker, prepare a solution of 3-fluoro-2-methylaniline (e.g., 0.1 mol), concentrated hydrochloric acid (e.g., 10 mL), and deionized water (e.g., 150 mL).
- **Hydroxylamine Solution:** In another beaker, dissolve hydroxylamine hydrochloride (e.g., 0.3 mol) in deionized water (e.g., 150 mL).
- **Reaction Initiation:** Heat the sodium sulfate/chloral hydrate solution to approximately 45-50°C. Concurrently, add the aniline solution and the hydroxylamine solution dropwise and simultaneously to the reaction flask over a period of 30-45 minutes, maintaining the temperature below 60°C.
- **Reaction and Precipitation:** After the addition is complete, heat the mixture to a gentle boil for 10-15 minutes. A yellow precipitate of the isonitrosoacetanilide intermediate should form.
- **Isolation:** Cool the reaction mixture in an ice bath. Collect the solid precipitate by vacuum filtration, wash thoroughly with cold water, and air-dry. The crude product can be used directly in the next step.

Step 2: Cyclization to **6-Fluoro-7-methylisatin**

- **Acid Addition (Caution: Exothermic):** In a 250 mL flask equipped with a stirrer and thermometer, place concentrated sulfuric acid (e.g., 100 mL) and cool it in an ice bath. Slowly and portion-wise, add the dried N-(3-fluoro-2-methylphenyl)-2-(hydroxyimino)acetamide (e.g., 20 g) from the previous step, ensuring the internal temperature does not exceed 65°C.
- **Heating:** Once the addition is complete, remove the ice bath and heat the dark solution to 80°C using an oil bath. Maintain this temperature and stir for 1-2 hours. Monitor the reaction by TLC until the starting material is consumed.
- **Quenching:** Allow the reaction to cool slightly before carefully and slowly pouring it into a large beaker containing crushed ice (e.g., 500 g) with vigorous stirring.
- **Product Isolation:** A brick-red or orange solid of **6-Fluoro-7-methylisatin** will precipitate. Allow the slurry to stir for an hour to ensure complete precipitation.
- **Purification:** Collect the solid by vacuum filtration. Wash the filter cake extensively with cold deionized water until the filtrate is neutral (pH ~7). The crude product can be further purified by recrystallization from a suitable solvent system like ethanol or ethyl acetate/petroleum ether to yield the final product.

PART 3: Spectroscopic Characterization

Accurate structural elucidation is critical. While experimental spectra for **6-Fluoro-7-methylisatin** are not widely published, its spectroscopic signature can be reliably predicted based on data from close analogs like 7-methylisatin and general principles of spectroscopy. [\[12\]](#)[\[13\]](#) A commercial supplier confirms that analytical data from NMR, MS, and other methods are available upon request for their product.[\[5\]](#)

3.1: Nuclear Magnetic Resonance (NMR) Spectroscopy

NMR is the most powerful tool for elucidating the precise molecular structure. For **6-Fluoro-7-methylisatin**, ¹H and ¹³C NMR will confirm the substitution pattern and overall carbon-hydrogen framework.

Protocol: NMR Sample Preparation and Analysis

- Sample Preparation: Dissolve 5-10 mg of purified **6-Fluoro-7-methylisatin** in ~0.6 mL of a suitable deuterated solvent (e.g., DMSO-d₆ or CDCl₃) in a 5 mm NMR tube.^[14]
- ¹H NMR Acquisition: Acquire a standard one-dimensional proton spectrum. Key signals to observe are the broad N-H singlet, the aromatic protons (which will show splitting due to H-F and H-H coupling), and the methyl singlet.
- ¹³C NMR Acquisition: Acquire a proton-decoupled ¹³C spectrum. This will require a greater number of scans. The spectrum will be characterized by two downfield carbonyl signals, aromatic carbon signals (with C-F coupling), and an upfield methyl signal.

Table 2: Predicted ¹H NMR Data for **6-Fluoro-7-methylisatin** (in DMSO-d₆)

Chemical Shift (δ, ppm)	Multiplicity	Integration	Assignment	Rationale / Notes
~11.2	s (broad)	1H	N-H	Typical chemical shift for isatin N-H proton; broad due to exchange and hydrogen bonding.[12]
~7.4-7.6	m	1H	Ar-H (H-4)	Aromatic proton, expected to be a multiplet due to coupling with H-5 and potentially long-range coupling to fluorine.
~7.0-7.2	m	1H	Ar-H (H-5)	Aromatic proton ortho to the fluorine atom; will show coupling to both H-4 and the fluorine atom.

| ~2.4 | s | 3H | -CH₃ | Singlet for the methyl group protons. |

Table 3: Predicted ¹³C NMR Data for **6-Fluoro-7-methylisatin** (in DMSO-d₆)

Chemical Shift (δ , ppm)	Assignment	Rationale / Notes
~183	C=O (C-2)	Amide carbonyl carbon, typically downfield.[12]
~159	C=O (C-3)	Ketone carbonyl carbon.[12]
~160 (d)	C-6	Carbon directly bonded to fluorine; will appear as a doublet with a large $^1J_{CF}$ coupling constant.
~145-150	C-7a	Quaternary carbon at the ring junction.
~120-130	C-4, C-5	Aromatic CH carbons.
~115-120 (d)	C-3a, C-7	Quaternary carbons; C-7 is adjacent to the fluorine-bearing carbon and may show a $^2J_{CF}$ coupling.

| ~15 | -CH₃ | Aliphatic methyl carbon signal in the upfield region. |

3.2: Infrared (IR) Spectroscopy

FT-IR spectroscopy is essential for identifying the key functional groups present in the molecule.

Protocol: FT-IR Sample Preparation (KBr Pellet)

- Preparation: Gently grind ~1-2 mg of dry **6-Fluoro-7-methylisatin** with ~100 mg of dry, spectroscopic-grade potassium bromide (KBr) using an agate mortar and pestle.
- Pellet Formation: Transfer the fine powder to a pellet press and apply pressure to form a thin, transparent pellet.
- Analysis: Place the pellet in the spectrometer's sample holder and acquire the spectrum, typically from 4000 to 400 cm⁻¹.[\[15\]](#)

Table 4: Characteristic IR Absorption Bands for **6-Fluoro-7-methylisatin**

Wavenumber (cm ⁻¹)	Vibration Type	Intensity	Notes
~3200	N-H Stretch	Medium, Broad	Characteristic of the lactam N-H group.[12]
~3100-3000	Aromatic C-H Stretch	Medium	Typical for sp ² C-H bonds.
~1750	C=O Stretch (C-2, Amide)	Strong	The lactam carbonyl typically absorbs at a higher frequency.
~1620	C=O Stretch (C-3, Ketone)	Strong	The ketone carbonyl, often in conjugation with the aromatic ring.
~1600, ~1480	C=C Stretch	Medium	Aromatic ring vibrations.

| ~1200-1100 | C-F Stretch | Strong | A strong, characteristic absorption for the aryl-fluoride bond.[16] |

3.3: Mass Spectrometry (MS)

Mass spectrometry confirms the molecular weight and can provide structural information through fragmentation patterns.

Protocol: Mass Spectrometry Analysis (ESI)

- **Sample Preparation:** Prepare a dilute solution of the compound in a suitable solvent like methanol or acetonitrile.
- **Analysis:** Infuse the solution into an Electrospray Ionization (ESI) mass spectrometer. Acquire spectra in both positive and negative ion modes.

Table 5: Predicted Mass Spectrometry Data for **6-Fluoro-7-methylisatin**

Adduct	Ion Type	Calculated m/z
[M+H]⁺	Positive	180.04553
[M+Na] ⁺	Positive	202.02747
[M-H] ⁻	Negative	178.03097

Data sourced from predicted values.[8] The molecular ion peak [M]^{+•} in Electron Impact (EI) ionization would be observed at m/z ≈ 179.

PART 4: Chemical Reactivity and Potential Applications

The reactivity of **6-Fluoro-7-methylisatin** is governed by the interplay of its isatin core and the electronic effects of its substituents. This makes it a versatile intermediate for creating diverse molecular libraries.

4.1: Key Reactive Sites

- **C3-Carbonyl Group:** This is the most reactive site, readily undergoing condensation reactions with a variety of nucleophiles (e.g., amines, hydrazines) to form Schiff bases and hydrazones.[4] This is a primary route for building molecular complexity.
- **N1-Amide Proton:** The acidic N-H proton can be deprotonated with a base, allowing for N-alkylation or N-arylation to introduce substituents that can modulate solubility and biological activity.
- **Aromatic Ring (C4, C5):** The benzene ring can undergo electrophilic aromatic substitution. The fluorine atom is an ortho-, para-director but deactivating, while the methyl group is an ortho-, para-director and activating. The substitution pattern will be a complex result of these competing effects, though positions C4 and C5 are the most likely sites for further functionalization.

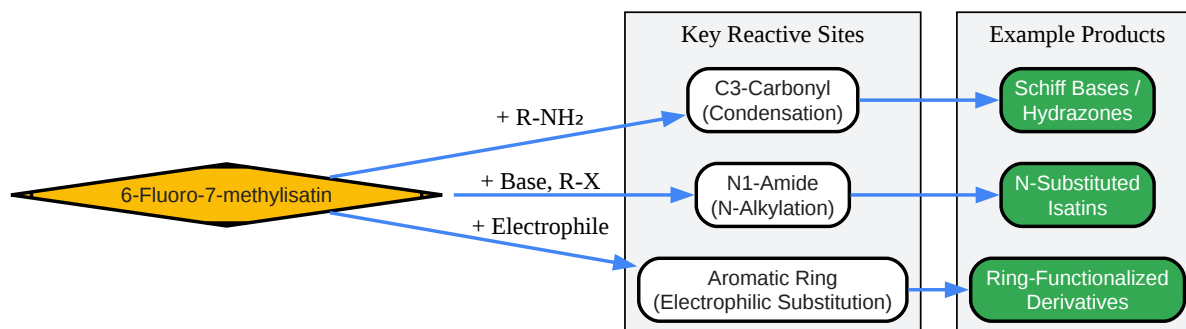

[Click to download full resolution via product page](#)

Caption: Key reactivity pathways for the **6-Fluoro-7-methylisatin** scaffold.

4.2: Potential Applications in Drug Discovery

While **6-Fluoro-7-methylisatin** itself has not been extensively studied, the broader class of fluorinated isatins exhibits significant pharmacological potential.

- **Anticancer Activity:** Many isatin derivatives function as inhibitors of cyclin-dependent kinases (CDKs) and other protein kinases, arresting the cell cycle in cancer cells.[3][17] Fluorination can enhance the binding affinity and cell permeability of these inhibitors.
- **Antiviral and Antimicrobial Agents:** Isatin-based thiosemicarbazones are a well-known class of antiviral agents.[4] The scaffold has also been used to develop potent antibacterial, antifungal, and antiparasitic compounds.[1][3] The specific substitution pattern of 6-fluoro-7-methyl may offer a unique structure-activity relationship (SAR) profile for developing new anti-infectives.
- **CNS-Active Agents:** Isatin is an endogenous compound in the brain and its derivatives have shown potential as anticonvulsant and anxiogenic agents.[3]

PART 5: Safety and Handling

Based on GHS classifications for the compound, **6-Fluoro-7-methylisatin** should be handled with care.

- Hazard Statements:
 - H315: Causes skin irritation.
 - H319: Causes serious eye irritation.
 - H335: May cause respiratory irritation.
- Precautionary Measures:
 - Wear protective gloves, eye protection, and face protection.
 - Use only outdoors or in a well-ventilated area. Avoid breathing dust.
 - Wash hands thoroughly after handling.[6]

Store in a cool, dry, well-ventilated place in a tightly sealed container.

References

- Dailey, S., & Locuson, C. (2012). Synthesis of Substituted Isatins. PMC. Available at: [\[Link\]](#)
- BenchChem Technical Support Team. (2025). The Sandmeyer Synthesis of Substituted Isatins: A Technical Guide for Drug Discovery. Scribd. Available at: [\[Link\]](#)
- SynArchive. (n.d.). Sandmeyer Isatin Synthesis. Available at: [\[Link\]](#)
- Unknown. (n.d.). Sandmeyer Isatin Synthesis.
- Royal Society of Chemistry. (2013). Catalytic Hydrotrifluoromethylation of Styrenes and Unactivated Aliphatic Alkenes via an Organic Photoredox System - Supporting Information. Available at: [\[Link\]](#)
- Mehta, B., & Singh, P. (2020). Synthesis of Isatin and Its Derivatives and their Applications in Biological System. Available at: [\[Link\]](#)

- Bogdanov, M. G., et al. (2022). Anticancer and Antiphytopathogenic Activity of Fluorinated Isatins and Their Water-Soluble Hydrazone Derivatives. PMC - PubMed Central. Available at: [\[Link\]](#)
- Unknown. (n.d.). Catalyzed Synthesis of Natural Alkaloid Tryptanthrin and Its Derivatives - Supporting Information. Available at: [\[Link\]](#)
- Royal Society of Chemistry. (n.d.). SUPPORTING INFORMATION CONFORMATIONAL STABILIZATION OF ISATIN SCHIFF BASES – BIOLOGICALLY ACTIVE CHEMICAL PROBES. Available at: [\[Link\]](#)
- Arkat USA. (2022). On the role of "mental leaps" in small-molecule structure elucidation by NMR spectroscopy. Available at: [\[Link\]](#)
- ResearchGate. (n.d.). Calculated and experimental ¹³C NMR chemical shifts. Available at: [\[Link\]](#)
- PubChemLite. (n.d.). **6-fluoro-7-methylisatin** (C₉H₆FNO₂). Available at: [\[Link\]](#)
- El-Faham, A., et al. (2013). Synthesis, characterization, and antiviral activity of novel fluorinated isatin derivatives. NIH. Available at: [\[Link\]](#)
- Teye, J., et al. (2022). A survey of isatin hybrids and their biological properties. PMC - PubMed Central. Available at: [\[Link\]](#)
- Royal Society of Chemistry. (2018). Supporting Information 1 Experimental Method Infrared spectroscopy Fourier transform infrared (FT-IR) spectra were recorded usin. Available at: [\[Link\]](#)
- Preprints.org. (2024). A Survey of Isatin Hybrids and their Biological Properties. Available at: [\[Link\]](#)
- PubChem. (n.d.). 6-Fluoroisatin. NIH. Available at: [\[Link\]](#)
- Wierer, P., et al. (2024). Infrared Spectroscopic Signatures of the Fluorous Effect Arise from a Change of Conformational Dynamics. PMC - NIH. Available at: [\[Link\]](#)

- Kuuja.com. (n.d.). 275374-94-2(7-Fluoro-6-Methyl Isatin). Available at: [[Link](#)]
- PubChem. (n.d.). 7-Methylisatin. NIH. Available at: [[Link](#)]

Need Custom Synthesis?

BenchChem offers custom synthesis for rare earth carbides and specific isotopic labeling.

Email: info@benchchem.com or [Request Quote Online](#).

Sources

1. A Survey of Isatin Hybrids and their Biological Properties[v1] | Preprints.org [[preprints.org](#)]
2. [biomedres.us](#) [[biomedres.us](#)]
3. Anticancer and Antiphytopathogenic Activity of Fluorinated Isatins and Their Water-Soluble Hydrazone Derivatives - PMC [[pmc.ncbi.nlm.nih.gov](#)]
4. Synthesis, characterization, and antiviral activity of novel fluorinated isatin derivatives - PMC [[pmc.ncbi.nlm.nih.gov](#)]
5. 6-Fluoro-7-Methyl Isatin [[synhet.com](#)]
6. Page loading... [[wap.guidechem.com](#)]
7. [alfa-chemistry.com](#) [[alfa-chemistry.com](#)]
8. PubChemLite - 6-fluoro-7-methylisatin (C₉H₆FNO₂) [[pubchemlite.lcsb.uni.lu](#)]
9. [synarchive.com](#) [[synarchive.com](#)]
10. Synthesis of Substituted Isatins - PMC [[pmc.ncbi.nlm.nih.gov](#)]
11. 7-Fluoroisatin synthesis - chemicalbook [[chemicalbook.com](#)]
12. [pdf.benchchem.com](#) [[pdf.benchchem.com](#)]
13. 7-Methylisatin | C₉H₇NO₂ | CID 14313 - PubChem [[pubchem.ncbi.nlm.nih.gov](#)]
14. [benchchem.com](#) [[benchchem.com](#)]
15. [rsc.org](#) [[rsc.org](#)]
16. Infrared Spectroscopic Signatures of the Fluorous Effect Arise from a Change of Conformational Dynamics - PMC [[pmc.ncbi.nlm.nih.gov](#)]
17. [scribd.com](#) [[scribd.com](#)]

- To cite this document: BenchChem. [Introduction: The Isatin Scaffold and the Significance of Fluorination]. BenchChem, [2026]. [Online PDF]. Available at: [<https://www.benchchem.com/product/b1279404/docs#introduction-the-isatin-scaffold-and-the-significance-of-fluorination>]

Disclaimer & Data Validity:

The information provided in this document is for Research Use Only (RUO) and is strictly not intended for diagnostic or therapeutic procedures. While BenchChem strives to provide accurate protocols, we make no warranties, express or implied, regarding the fitness of this product for every specific experimental setup.

Technical Support: The protocols provided are for reference purposes. Unsure if this reagent suits your experiment?

Need Industrial/Bulk Grade? [Request Custom Synthesis Quote](#)

BenchChem

Our mission is to be the trusted global source of essential and advanced chemicals, empowering scientists and researchers to drive progress in science and industry.

Contact

Address: 3281 E Guasti Rd
Ontario, CA 91761, United States
Phone: (601) 213-4426
Email: info@benchchem.com

[Contact our Ph.D. Support Team for a compatibility check](#)