

Application Notes & Protocols: Sonogashira Coupling of 7-Bromoindoline

Author: BenchChem Technical Support Team. **Date:** May 2026

Compound of Interest

Compound Name: 7-Bromoindoline

CAS No.: 62813-85-8

Cat. No.: B1279588

[Get Quote](#)

Introduction: The Strategic Importance of 7-Alkynyndolines

The indoline scaffold is a privileged structure in medicinal chemistry, forming the core of numerous natural products and pharmaceutical agents. The targeted functionalization of this motif is a cornerstone of modern drug discovery. Among the myriad of synthetic transformations, the palladium-catalyzed Sonogashira cross-coupling reaction stands out as a powerful and versatile method for the formation of carbon-carbon bonds between sp^2 -hybridized aryl halides and sp -hybridized terminal alkynes.^[1]

This guide provides a detailed technical overview and actionable protocols for the Sonogashira coupling of **7-bromoindoline**. The introduction of an alkynyl group at the 7-position of the indoline ring system generates 7-alkynyndolines, crucial intermediates for synthesizing complex molecules, including therapeutic agents and advanced organic materials.^[1] We will delve into the mechanistic underpinnings of the reaction, critical experimental parameters, optimization strategies, and troubleshooting, with a specific focus on the unique challenges presented by the **7-bromoindoline** substrate.

Mechanistic Rationale: The Dual Catalytic Cycle

The success of a Sonogashira coupling hinges on the synergistic interplay of two interconnected catalytic cycles: a palladium cycle and a copper cycle.^{[1][2]} Understanding this dual mechanism is paramount for rational troubleshooting and optimization.

- **The Palladium Cycle:** The primary cross-coupling engine. It begins with the oxidative addition of the aryl halide (**7-bromoindoline**) to a coordinatively unsaturated Pd(0) species, forming a Pd(II) intermediate. This is often the rate-limiting step, particularly for less reactive aryl bromides compared to iodides.^{[2][3]}
- **The Copper Cycle:** This cycle's role is to activate the terminal alkyne. A copper(I) salt reacts with the terminal alkyne in the presence of a base to form a copper(I) acetylide intermediate.^[1] This species is more reactive towards transmetalation.
- **Transmetalation & Reductive Elimination:** The copper acetylide transfers its alkynyl group to the Pd(II) complex in a step called transmetalation. The resulting dialkynyl-aryl-Pd(II) complex then undergoes reductive elimination to yield the final alkynylated product and regenerate the active Pd(0) catalyst, thus completing the cycle.^[3]

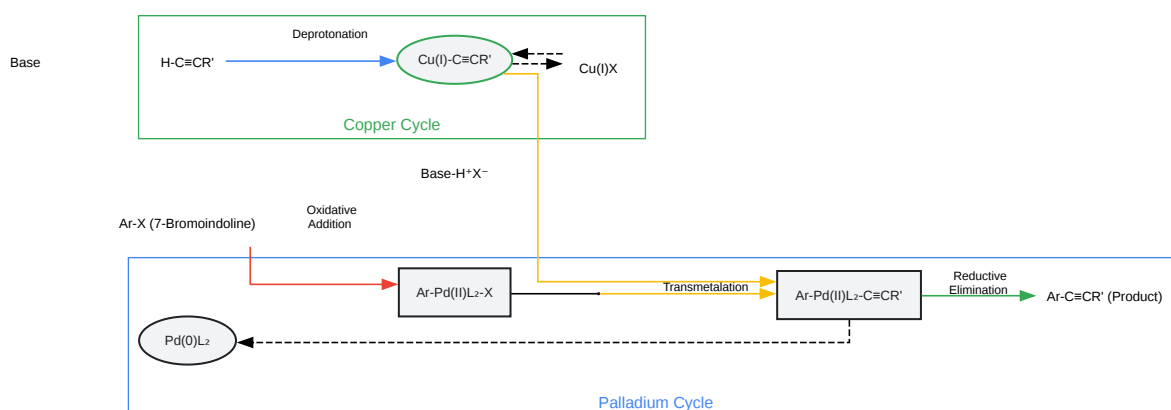

Figure 1: The Dual Catalytic Cycle of Sonogashira Coupling

[Click to download full resolution via product page](#)

Caption: A simplified representation of the interconnected palladium and copper catalytic cycles in the Sonogashira reaction.

Core Requirements and Optimization for 7-Bromoindoline

The successful coupling of **7-bromoindoline** requires careful consideration of several factors, primarily stemming from the moderate reactivity of the C-Br bond and the presence of the acidic N-H proton.

The N-H Acidity Challenge: To Protect or Not to Protect?

The proton on the indoline nitrogen is acidic and can interfere with the reaction by reacting with the base or catalyst.[4] This can lead to catalyst inhibition, side reactions like debromination, or low yields.[5]

- **Expertise & Experience:** For most applications involving **7-bromoindoline**, N-protection is highly recommended. Protecting groups like tert-butoxycarbonyl (Boc), tosyl (Ts), or benzenesulfonyl (Bs) effectively mask the acidic proton, leading to more reproducible results and higher yields. The choice of protecting group will depend on the overall synthetic strategy and the conditions required for its eventual removal. While couplings on N-protected indoles have been reported, they often require specific, highly optimized catalyst systems.[4]

Selecting the Catalytic System

- **Palladium Source:** Standard palladium(II) precatalysts like $\text{PdCl}_2(\text{PPh}_3)_2$ are robust, commercially available, and effective.[6] They are reduced in situ to the active Pd(0) species.[1] Other common sources include $\text{Pd}(\text{PPh}_3)_4$ and $\text{Pd}(\text{OAc})_2$.
- **Ligand:** For aryl bromides, the choice of ligand is crucial. While triphenylphosphine (PPh_3) is standard, more electron-rich and bulky phosphine ligands (e.g., Buchwald ligands like XPhos) can accelerate the rate-limiting oxidative addition step and improve catalyst stability, which is particularly useful for less reactive substrates.[4][7]
- **Copper(I) Co-catalyst:** Copper(I) iodide (CuI) is the most common co-catalyst.[6] It is essential for the classical Sonogashira mechanism. However, its presence can promote the undesirable oxidative homocoupling of the terminal alkyne (Glaser coupling), especially if oxygen is not rigorously excluded.[5]
- **Copper-Free Conditions:** To circumvent the issue of Glaser homocoupling, copper-free Sonogashira protocols have been developed.[4] These methods often rely on more active palladium catalysts and may use different bases or solvents to facilitate the reaction without the copper co-catalyst.[8] This is a key consideration if the alkyne homodimer is a problematic impurity.

The Role of Base and Solvent

- Base: An amine base, such as triethylamine (Et₃N) or diisopropylethylamine (DIPEA), is typically used.[4] It serves both to deprotonate the alkyne and to act as a solvent or co-solvent. For more challenging couplings, inorganic bases like Cs₂CO₃ or K₂CO₃ can be effective, particularly in copper-free systems.[4][9]
- Solvent: The solvent must effectively dissolve all reaction components. Tetrahydrofuran (THF) and N,N-dimethylformamide (DMF) are common choices.[4] Toluene or dioxane can also be excellent options.[4] The choice can significantly impact reaction rates and catalyst stability.

Reaction Temperature

While many Sonogashira reactions can proceed at room temperature, the coupling of aryl bromides like **7-bromoindoline** often requires heating to facilitate oxidative addition.[3]

Temperatures in the range of 50-80 °C are a good starting point for optimization.[6]

Comparative Data: Sonogashira Conditions for Bromo-N-Heterocycles

The following table summarizes representative conditions for Sonogashira couplings on N-protected 7-bromoindole and structurally similar substrates, providing a valuable starting point for experimental design.

Substrate	Alkyne	Pd Catalyst (mol %)	Ligand	CuI (mol %)	Base	Solvent	Temp (°C)	Yield (%)	Ref.
N-Boc-7-bromoindole	Phenyl acetylene	PdCl ₂ (PPh ₃) ₂ (3)	PPh ₃	2	Et ₃ N	THF	65	High	[10]
N-Tosyl-7-bromoindole	Trimethylsilyl acetylene	Pd(OAc) ₂ (2)	XPhos	—	Cs ₂ CO ₃	Dioxane	100	~85-95	[6]
N-Protected 7-bromoindole	1-Heptyne	PdCl ₂ (PPh ₃) ₂ (5)	PPh ₃	5	i-Pr ₂ NH	DMF	RT - 80	Good	[6]
2-Bromoaniline Derivative	Various Alkynes	[DTBNpP]Pd(crotyl)Cl (2)	DTBNpP	—	Cs ₂ CO ₃	DMSO	RT	80-99	[8]
Aryl Bromide	Phenyl acetylene	Pd(PPH ₃) ₂ Cl ₂ (5)	PPh ₃	2.5	i-Pr ₂ NH	THF	RT	89	[3]

Detailed Experimental Protocol

This protocol describes a general procedure for the Sonogashira coupling of N-Boc-7-bromoindole with phenylacetylene. It should be adapted and optimized for different substrates and scales.

Title: Palladium-Catalyzed Sonogashira Coupling of N-Boc-7-bromoindole with Phenylacetylene.

Materials & Reagents:

- N-Boc-7-bromoindole (1.0 equiv.)
- Phenylacetylene (1.2 equiv.)
- Bis(triphenylphosphine)palladium(II) dichloride [PdCl₂(PPh₃)₂] (3 mol%)
- Copper(I) iodide [CuI] (2 mol%)
- Triethylamine (Et₃N) (3.0 equiv.)
- Anhydrous, degassed Tetrahydrofuran (THF)
- Argon or Nitrogen gas supply
- Standard Schlenk line glassware and magnetic stirrer

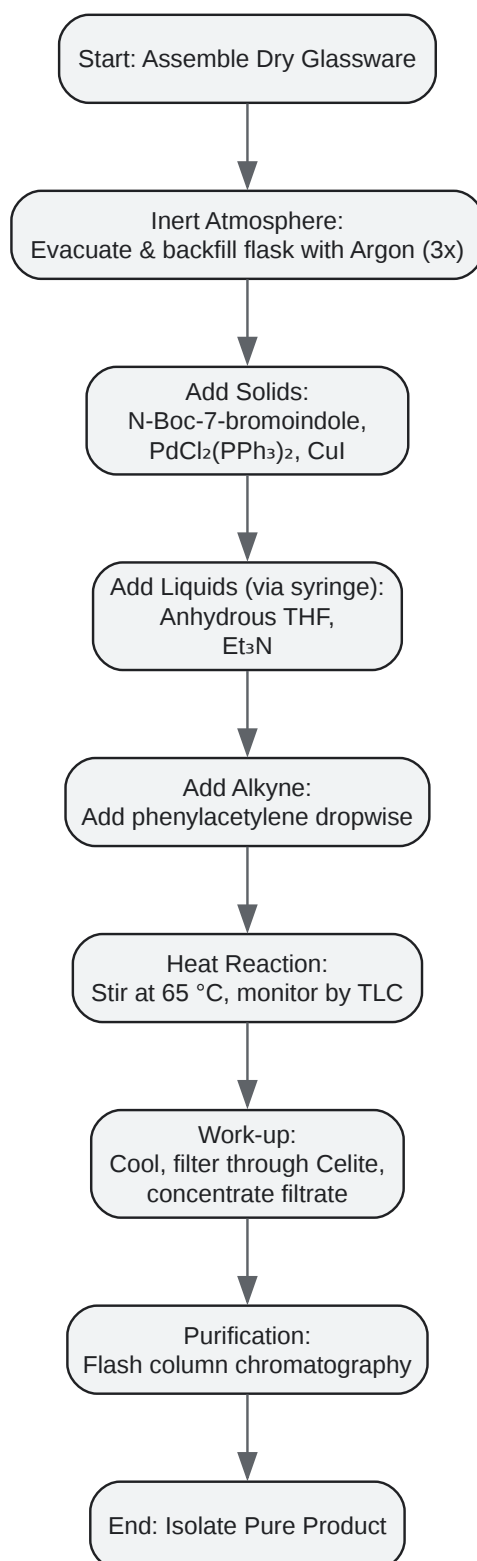

Figure 2: Experimental Workflow

[Click to download full resolution via product page](#)

Need Custom Synthesis?

BenchChem offers custom synthesis for rare earth carbides and specific isotopic labeling.

Email: info@benchchem.com or [Request Quote Online](#).

Sources

- [1. Sonogashira coupling - Wikipedia \[en.wikipedia.org\]](#)
- [2. youtube.com \[youtube.com\]](#)
- [3. Sonogashira Coupling | NROChemistry \[nrochemistry.com\]](#)
- [4. pdf.benchchem.com \[pdf.benchchem.com\]](#)
- [5. pdf.benchchem.com \[pdf.benchchem.com\]](#)
- [6. pdf.benchchem.com \[pdf.benchchem.com\]](#)
- [7. pdf.benchchem.com \[pdf.benchchem.com\]](#)
- [8. researchgate.net \[researchgate.net\]](#)
- [9. A Practical Mild, One-Pot, Regiospecific Synthesis of 2,3-Disubstituted Indoles via Consecutive Sonogashira and Cacchi Reactions \[organic-chemistry.org\]](#)
- [10. pdf.benchchem.com \[pdf.benchchem.com\]](#)
- To cite this document: BenchChem. [Application Notes & Protocols: Sonogashira Coupling of 7-Bromoindoline]. BenchChem, [2026]. [Online PDF]. Available at: [\[https://www.benchchem.com/product/b1279588/docs#application-notes-protocols-sonogashira-coupling-of-7-bromoindoline\]](https://www.benchchem.com/product/b1279588/docs#application-notes-protocols-sonogashira-coupling-of-7-bromoindoline)

Disclaimer & Data Validity:

The information provided in this document is for Research Use Only (RUO) and is strictly not intended for diagnostic or therapeutic procedures. While BenchChem strives to provide accurate protocols, we make no warranties, express or implied, regarding the fitness of this product for every specific experimental setup.

Technical Support: The protocols provided are for reference purposes. Unsure if this reagent suits your experiment?

Need Industrial/Bulk Grade? [Request Custom Synthesis Quote](#)

BenchChem

Our mission is to be the trusted global source of essential and advanced chemicals, empowering scientists and researchers to drive progress in science and industry.

Contact

Address: 3281 E Guasti Rd
Ontario, CA 91761, United States
Phone: (601) 213-4426
Email: info@benchchem.com

[Contact our Ph.D. Support Team for a compatibility check](#)