

Application Note: Two-Step Protein Labeling via N-Terminal Modification with 3-Azidopropanal

Author: BenchChem Technical Support Team. **Date:** May 2026

Compound of Interest

Compound Name: 3-Azidopropanal

CAS No.: 58503-60-9

Cat. No.: B1279046

[Get Quote](#)

Introduction

Site-specific protein modification is a cornerstone of modern chemical biology, enabling researchers to probe protein function, track cellular processes, and develop novel biotherapeutics. A key challenge lies in achieving high selectivity for a single site on the protein to ensure homogeneity and preserve native function. The N-terminal α -amine presents a unique target due to its distinct pKa compared to the ϵ -amines of lysine residues, allowing for chemoselective modification under controlled pH conditions.[1]

This application note details a robust, two-step protocol for the site-specific labeling of proteins. The strategy leverages the bifunctional nature of **3-Azidopropanal**, a reagent containing both an aldehyde and an azide group. In the first step, the aldehyde moiety is used to selectively modify the protein's N-terminus via reductive amination. This reaction installs a versatile azide handle onto the protein with high efficiency. In the second step, this bioorthogonal azide group is conjugated to a molecule of interest (e.g., a fluorophore, biotin, or drug molecule) bearing an alkyne group, using the highly specific and efficient copper(I)-catalyzed azide-alkyne cycloaddition (CuAAC) click reaction.[2] This modular approach provides a powerful platform

for creating precisely defined protein conjugates for a wide range of applications in research and drug development.

Principle of the Method

The labeling strategy is executed in two sequential stages, as outlined below. This method bridges the gap between classic N-terminal modification chemistries and modern bioorthogonal ligations.

Step 1: N-Terminal Azido-Functionalization via Reductive Amination

The process begins with the selective reaction between the N-terminal α -amine of the target protein and the aldehyde of **3-Azidopropanal**. This reaction forms an initial, reversible Schiff base intermediate. A mild reducing agent, sodium cyanoborohydride (NaBH_3CN), is then used to reduce the Schiff base to a stable secondary amine bond.[3] The lower pKa of the N-terminal α -amine (typically 6.0-8.0) compared to lysine ϵ -amines (pKa \approx 10.5) allows this reaction to be performed at a slightly acidic to neutral pH (pH 6.5-7.5), where the N-terminus is more nucleophilic, thus favoring site-specific modification.[1] This step effectively transforms the protein's N-terminus into a reactive azide handle.

Step 2: Bioorthogonal "Click" Ligation

The azide-functionalized protein is then subjected to a click chemistry reaction. The most common method is the Copper(I)-Catalyzed Azide-Alkyne Cycloaddition (CuAAC). In this reaction, the terminal azide on the protein undergoes a [3+2] cycloaddition with a terminal alkyne on the probe molecule. The reaction is catalyzed by Cu(I), which is typically generated in situ from a Cu(II) source like copper(II) sulfate (CuSO_4) by a reducing agent such as sodium ascorbate.[4][5] The resulting triazole linkage is exceptionally stable, forming a permanent covalent bond between the protein and the probe. For biological systems where copper toxicity is a concern, a copper-free alternative, Strain-Promoted Azide-Alkyne Cycloaddition (SPAAC), can be employed using a strained cyclooctyne probe.[6][7]

Visualization of the Labeling Workflow

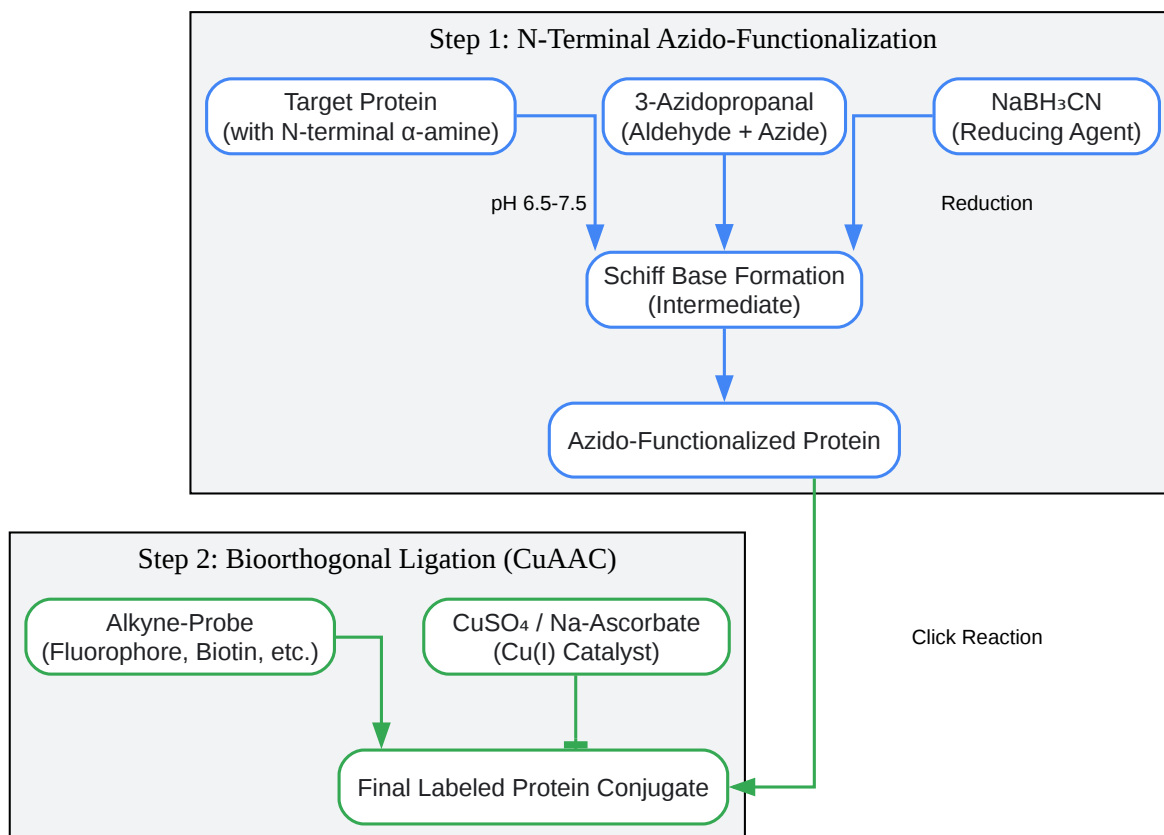

[Click to download full resolution via product page](#)

Caption: Overall workflow for the two-step protein labeling protocol.

Experimental Protocols

Protocol 1: N-Terminal Azido-Functionalization of Target Protein

This protocol describes the modification of a protein's N-terminus with **3-Azidopropanal**.

Materials:

- Target Protein (purified, in a buffer free of primary amines, e.g., PBS or HEPES)
- **3-Azidopropanal** (handle with care, see safety notes)
- Reaction Buffer: 100 mM Phosphate buffer, pH 7.0
- Sodium Cyanoborohydride (NaBH₃CN) stock solution: 1 M in water (prepare fresh)
- Desalting spin columns or dialysis cassettes (appropriate MWCO)

Procedure:

- Protein Preparation: Adjust the concentration of the target protein to 1-5 mg/mL in the Reaction Buffer.
- Reagent Addition: Add a 50 to 200-fold molar excess of **3-Azidopropanal** to the protein solution. Mix gently by pipetting.
- Initial Incubation: Incubate the mixture for 1-2 hours at room temperature with gentle shaking to allow for Schiff base formation.
- Reduction Step: Add NaBH₃CN from the stock solution to a final concentration of 20-50 mM.
 - Expert Tip: Add the reducing agent in aliquots to control any potential effervescence. The choice of concentration depends on the protein's tolerance; start with a lower concentration to minimize potential side reactions.
- Reaction Incubation: Allow the reaction to proceed for 4-12 hours at room temperature or overnight at 4°C.
- Purification: Remove excess reagents (**3-Azidopropanal** and NaBH₃CN) by passing the reaction mixture through a desalting spin column or by dialyzing against PBS (pH 7.4) overnight at 4°C.
- Verification (Optional but Recommended): Confirm the mass modification using mass spectrometry (e.g., ESI-MS). The expected mass increase corresponds to the addition of a C₃H₅N₃ moiety (+83.05 Da).

- Storage: Store the purified azido-functionalized protein at -20°C or -80°C for long-term use.

Visualization of the Reductive Amination Reaction

Caption: Reaction scheme for N-terminal reductive amination.

Protocol 2: CuAAC "Click" Labeling of Azido-Functionalized Protein

This protocol describes the conjugation of an alkyne-containing probe to the azido-functionalized protein.

Materials:

- Azido-Functionalized Protein (from Protocol 1)
- Alkyne-Probe (e.g., Alkyne-Biotin, Alkyne-Fluorophore) stock solution: 10 mM in DMSO
- Copper(II) Sulfate (CuSO_4) stock solution: 50 mM in water
- Tris(3-hydroxypropyltriazolylmethyl)amine (THPTA) stock solution: 50 mM in water
- Sodium Ascorbate (Na-Asc) stock solution: 100 mM in water (prepare fresh, protect from light)
- PBS (pH 7.4)

Procedure:

- Reaction Setup: In a microcentrifuge tube, combine the following in order:
 - Azido-Functionalized Protein (to a final concentration of 1-2 mg/mL in PBS).
 - Alkyne-Probe (add to a final concentration of 10-20 fold molar excess over the protein).
- Catalyst Premix: In a separate tube, premix CuSO_4 and THPTA at a 1:5 ratio. Add this premix to the protein solution to achieve a final CuSO_4 concentration of 0.5-1 mM. Mix gently.

- Expert Tip: THPTA is a ligand that stabilizes the Cu(I) oxidation state and protects the protein from copper-induced damage.[4] Premixing is crucial.
- Reaction Initiation: Add the freshly prepared Sodium Ascorbate solution to a final concentration of 2-5 mM to initiate the click reaction.
- Incubation: Incubate the reaction for 1-4 hours at room temperature, protected from light. Reaction progress can be monitored by SDS-PAGE if using a fluorescent alkyne-probe.
- Purification: Remove excess reagents and catalyst using a desalting spin column, dialysis, or size-exclusion chromatography.
- Analysis and Confirmation:
 - SDS-PAGE: Analyze the purified, labeled protein. A band shift or fluorescence signal (for fluorescent probes) compared to the unlabeled control will confirm conjugation.
 - Western Blot: For biotin-labeled proteins, detection with streptavidin-HRP will confirm successful labeling.
 - Mass Spectrometry: ESI-MS will show a mass shift corresponding to the addition of the alkyne-probe.

Data Summary and Troubleshooting

Parameter	Protocol 1: Azido-Functionalization	Protocol 2: CuAAC Labeling
Protein Conc.	1-5 mg/mL	1-2 mg/mL
Reagent Molar Excess	50-200x (3-Azidopropanal)	10-20x (Alkyne-Probe)
Key Reagent Conc.	20-50 mM NaBH ₃ CN	0.5-1 mM CuSO ₄ , 2-5 mM Na-Asc
pH	6.5-7.5	7.4
Temperature	4°C to RT	Room Temperature
Reaction Time	4-12 hours	1-4 hours

Potential Issue	Possible Cause	Suggested Solution
Low Labeling Efficiency	Suboptimal pH for reductive amination; Inactive catalyst in click step; Steric hindrance at N-terminus.	Optimize pH for Step 1; Always use freshly prepared sodium ascorbate for Step 2; Increase reaction time or reagent excess.
Protein Precipitation	Protein instability; Aggregation caused by DMSO from probe stock; Copper-induced damage.	Perform reactions at 4°C; Limit DMSO concentration to <5% (v/v); Ensure THPTA ligand is used in the click reaction.
Non-specific Labeling	Reaction pH is too high, leading to lysine modification.	Maintain reaction pH for reductive amination at or below 7.5 to maximize N-terminal selectivity.

Safety Considerations

- **Azido Compounds:** Low molecular weight organic azides like **3-Azidopropanal** can be energetic and potentially explosive, especially if heated or subjected to shock. Handle with appropriate personal protective equipment (PPE) in a well-ventilated fume hood. Avoid contact with heavy metals.[8]
- **Sodium Cyanoborohydride:** NaBH₃CN is toxic and can release hydrogen cyanide gas upon contact with strong acids. Handle with care and appropriate PPE.
- **Copper Catalyst:** Copper salts can be toxic to cells and may damage proteins. Use chelating ligands like THPTA and remove all traces of copper after the reaction if the conjugate is for cellular use.

References

- Agarwal, P., et al. (2013). A Pictet-Spengler ligation for protein chemical modification. Proceedings of the National Academy of Sciences, 110(1), 46-51. [<https://www.pnas.org/doi/10.1073/pnas.1215183110>][9][10][11]

- Witte, M.D., et al. (2013). Hydrazino-Pictet-Spengler Ligation as a Biocompatible Method for the Generation of Stable Protein Conjugates. *Bioconjugate Chemistry*, 24(6), 846-851. [<https://pubs.acs.org/doi/10.1021/bc400042a>][12][13]
- Geoghegan, K.F., & Stroh, J.G. (1992). Site-directed conjugation of nonpeptide groups to peptides and proteins via periodate oxidation of a 2-amino alcohol. Application to modification at N-terminal serine. *Bioconjugate Chemistry*, 3(2), 138-146. [<https://pubs.acs.org/doi/10.1021/bc00014a002>][14]
- Gentile, F., et al. (2021). Exploiting Protein N-Terminus for Site-Specific Bioconjugation. *Molecules*, 26(12), 3535. [<https://www.ncbi.nlm.nih.gov/pmc/articles/PMC8226955/>][3]
- Francis, M.B. (2011). Targeting the N terminus for site-selective protein modification. *Chemical Science*, 2(7), 1226-1233. [https://www.researchgate.net/publication/257858635_Targeting_the_N_terminus_for_site-selective_protein_modification][1]
- ChemicalBook. (2023). 1-Propanol, 3-azido-. ChemicalBook. [https://www.chemicalbook.com/ChemicalProductProperty_EN_CB62696348.htm][15]
- ResearchGate. (2020). Safety of synthesizing 3-azidopropylamine?. ResearchGate. [https://www.researchgate.net/post/Safety_of_synthesizing_3-azidopropylamine][8]
- Chemsrvc. (2024). 1-Propanol, 3-azido-. Chemsrvc. [https://www.chemsrc.com/en/cas/72320-38-8_1057801.html][16]
- BenchChem. (2025). Application Notes and Protocols for Bioconjugation with Azido-PEG7-acid. BenchChem. [<https://www.benchchem.com/application-notes/B1066804>][4]
- Jiang, X., et al. (2019). Recent applications of click chemistry in drug discovery. *Expert Opinion on Drug Discovery*, 14(8), 779-789. [<https://www.tandfonline.com/doi/full/10.1080/17460441.2019.1623886>][2]
- Nessen, M.A., et al. (2020). Synthesis of Bioconjugation Reagents for Use in Covalent Cross-Linking of Proteins by Azide-Alkyne Cycloaddition. *Molecules*, 25(18), 4129. [<https://www.ncbi.nlm.nih.gov/pmc/articles/PMC7570490/>][17]

- Scigine. (2020). Protein DNA Bioconjugate Protocol. YouTube. [https://www.youtube.com/watch?v=Fj-G5z_u-iY][6]
- BenchChem. (2025). Application Notes and Protocols for Peptide Bioconjugation with Azido-PEG12-propargyl. BenchChem. [<https://www.benchchem.com/application-notes/B1069695>] [5]
- McKay, C.S., & Finn, M.G. (2014). Practical Considerations, Challenges, and Limitations of Bioconjugation via Azide-Alkyne Cycloaddition. *Chemistry & Biology*, 21(9), 1075-1101. [<https://www.ncbi.nlm.nih.gov/pmc/articles/PMC4244583/>][7]
- Ma, Y., & Yates, J.R. 3rd. (2018). Proteomics and pulse azidohomoalanine labeling of newly synthesized proteins: what are the potential applications?. *Expert Review of Proteomics*, 15(7), 545-554. [<https://www.ncbi.nlm.nih.gov/pmc/articles/PMC6329588/>][18][19]
- Zhang, C., et al. (2016). A novel approach to the site-selective dual labelling of a protein via chemoselective cysteine modification. *Chemical Communications*, 52(72), 10888-10891. [<https://pubs.rsc.org/en/content/articlelanding/2016/cc/c6cc05581a>][20]
- Basle, E., et al. (2010). Selective N-terminal modification of peptides and proteins. *Chemical Society Reviews*, 39(8), 3117-3131. [<https://pubs.rsc.org/en/content/articlelanding/2010/cs/b926830c>][21]

Need Custom Synthesis?

BenchChem offers custom synthesis for rare earth carbides and specific isotopic labeling.

Email: info@benchchem.com or [Request Quote Online](#).

Sources

- [1. researchgate.net](https://www.researchgate.net) [researchgate.net]
- [2. Recent Advances about the Applications of Click Reaction in Chemical Proteomics | MDPI](https://www.mdpi.com) [mdpi.com]
- [3. Exploiting Protein N-Terminus for Site-Specific Bioconjugation - PMC](https://pubmed.ncbi.nlm.nih.gov/) [pmc.ncbi.nlm.nih.gov]

- [4. pdf.benchchem.com \[pdf.benchchem.com\]](https://pdf.benchchem.com)
- [5. pdf.benchchem.com \[pdf.benchchem.com\]](https://pdf.benchchem.com)
- [6. m.youtube.com \[m.youtube.com\]](https://m.youtube.com)
- [7. Practical Considerations, Challenges, and Limitations of Bioconjugation via Azide-Alkyne Cycloaddition - PMC \[pmc.ncbi.nlm.nih.gov\]](#)
- [8. researchgate.net \[researchgate.net\]](https://researchgate.net)
- [9. pnas.org \[pnas.org\]](https://pnas.org)
- [10. A Pictet-Spengler ligation for protein chemical modification - PubMed \[pubmed.ncbi.nlm.nih.gov\]](#)
- [11. researchgate.net \[researchgate.net\]](https://researchgate.net)
- [12. pubs.acs.org \[pubs.acs.org\]](https://pubs.acs.org)
- [13. Hydrazino-Pictet-Spengler ligation as a biocompatible method for the generation of stable protein conjugates - PubMed \[pubmed.ncbi.nlm.nih.gov\]](#)
- [14. pubs.acs.org \[pubs.acs.org\]](https://pubs.acs.org)
- [15. 1-Propanol, 3-azido- | 72320-38-8 \[chemicalbook.com\]](#)
- [16. 1-Propanol, 3-azido | CAS#:72320-38-8 | Chemsrvc \[chemsrc.com\]](#)
- [17. Synthesis of Bioconjugation Reagents for Use in Covalent Cross-Linking of Proteins by Azide-Alkyne Cycloaddition - PMC \[pmc.ncbi.nlm.nih.gov\]](#)
- [18. Proteomics and pulse azidohomoalanine labeling of newly synthesized proteins: what are the potential applications? - PMC \[pmc.ncbi.nlm.nih.gov\]](#)
- [19. Proteomics and pulse azidohomoalanine labeling of newly synthesized proteins: what are the potential applications? - PubMed \[pubmed.ncbi.nlm.nih.gov\]](#)
- [20. A novel approach to the site-selective dual labelling of a protein via chemoselective cysteine modification - PMC \[pmc.ncbi.nlm.nih.gov\]](#)
- [21. Selective N-terminal modification of peptides and proteins: Recent progresses and applications \[ccspublishing.org.cn\]](#)
- [To cite this document: BenchChem. \[Application Note: Two-Step Protein Labeling via N-Terminal Modification with 3-Azidopropanal\]. BenchChem, \[2026\]. \[Online PDF\]. Available at: \[https://www.benchchem.com/product/b1279046/docs#application-note-two-step-protein-labeling-via-n-terminal-modification-with-3-azidopropanal\]](#)

Disclaimer & Data Validity:

The information provided in this document is for Research Use Only (RUO) and is strictly not intended for diagnostic or therapeutic procedures. While BenchChem strives to provide accurate protocols, we make no warranties, express or implied, regarding the fitness of this product for every specific experimental setup.

Technical Support: The protocols provided are for reference purposes. Unsure if this reagent suits your experiment?

Need Industrial/Bulk Grade? [Request Custom Synthesis Quote](#)

BenchChem

Our mission is to be the trusted global source of essential and advanced chemicals, empowering scientists and researchers to drive progress in science and industry.

Contact

Address: 3281 E Guasti Rd
Ontario, CA 91761, United States
Phone: (601) 213-4426
Email: info@benchchem.com

[Contact our Ph.D. Support Team for a compatibility check](#)