

# Application Note: Strategic Screening and Biological Profiling of Novel Pyridine Derivatives

**Author:** BenchChem Technical Support Team. **Date:** May 2026

## Compound of Interest

Compound Name: *6-Pyrrolidin-1-ylpyridine-2-carbonitrile*

CAS No.: *160017-13-0*

Cat. No.: *B1279307*

[Get Quote](#)

## Introduction: The Pyridine Privilege and the Screening Paradox

The pyridine moiety is arguably the most "privileged" nitrogen heterocycle in modern medicinal chemistry, serving as the core scaffold for over 100 FDA-approved drugs, including Sorafenib (Nexium), Isoniazid, and Claritin. Its ability to accept hydrogen bonds (via the ring nitrogen) and participate in

-stacking interactions makes it an ideal candidate for targeting ATP-binding pockets of kinases, G-Protein Coupled Receptors (GPCRs), and microbial enzymes.

However, the physicochemical properties that make pyridines potent—specifically their lipophilicity and basicity—introduce significant challenges in early-stage screening. Novel pyridine derivatives are prone to colloidal aggregation and non-specific heme coordination, leading to frequent "false positives" (promiscuous inhibition) in high-throughput screening (HTS).

This guide provides a rigorous, self-validating workflow to screen novel pyridine libraries, distinguishing true pharmacological hits from assay artifacts.

## Phase I: Compound Management & Quality Control

Before biological interrogation, the integrity of the chemical library must be established.

Pyridine derivatives often exhibit poor aqueous solubility as free bases.

### Protocol A: Stock Preparation and Solubility Verification

Objective: Ensure compound homogeneity and prevent precipitation-induced artifacts.

- Solubilization: Dissolve solid pyridine derivatives in 100% anhydrous DMSO to a stock concentration of 10 mM.
  - Critical Note: If the pyridine is a free base, verify that it does not precipitate upon dilution into aqueous buffers (pH 7.4). If precipitation occurs, conversion to a hydrochloride (HCl) or mesylate salt is recommended before screening.
- Visual Inspection: Centrifuge stock plates at 1,000 x g for 1 minute. Any pellet formation indicates insolubility.
- DMSO Tolerance Check: Determine the maximum DMSO tolerance of your target assay (typically 0.1% - 1.0%). Pyridines are often hydrophobic; ensure the final assay buffer contains sufficient carrier without inhibiting the enzyme.

### Protocol B: The Aggregation Counter-Screen (Mandatory)

Context: Many hydrophobic pyridines form colloidal aggregates that sequester enzymes, mimicking inhibition. This is the #1 cause of false positives in kinase assays.

Methodology:

- Standard Run: Measure IC<sub>50</sub> in standard assay buffer.

- Detergent Challenge: Repeat the IC

measurement in buffer supplemented with 0.01% Triton X-100 (or Tween-80).

- Interpretation: If the IC

shifts significantly (e.g., from 1

M to >50

M) in the presence of detergent, the compound is likely an aggregator (False Positive). True inhibitors will retain potency.

- Centrifugation Test: Spin the reaction mixture at 10,000 x g for 10 minutes. If the "inhibitory" activity is found in the pellet, the compound is an aggregator.

## Phase II: Primary Screening – Kinase Inhibition

Target Class: Protein Kinases (e.g., EGFR, CDK9, VEGFR). Mechanism: Pyridines typically act as Type I inhibitors, binding to the hinge region of the kinase ATP-binding pocket.

### Diagram: Mechanism of Action & Screening Logic

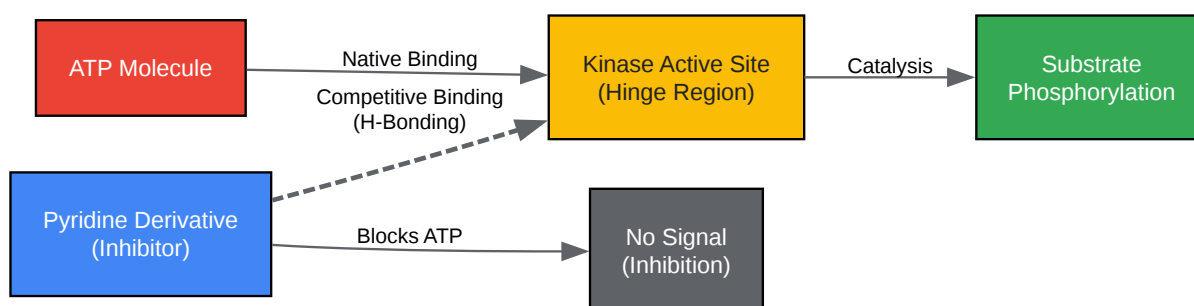

[Click to download full resolution via product page](#)

Caption: Competitive inhibition mechanism where the pyridine scaffold displaces ATP at the kinase hinge region.

## Protocol C: FRET-Based Kinase Assay (Z'-Lyte or LanthaScreen)

Rationale: Fluorescence Resonance Energy Transfer (FRET) offers a ratiometric readout that is less susceptible to compound fluorescence (a common issue with conjugated pyridines) than intensity-based assays.

Reagents:

- Kinase Enzyme (e.g., recombinant EGFR).
- FRET Peptide Substrate (Coumarin/Fluorescein pair).
- ATP (at concentration).
- Test Compounds (Pyridine library).

Step-by-Step Procedure:

- Plate Setup: Use 384-well low-volume black plates.
- Compound Addition: Dispense 100 nL of compound (in DMSO) using an acoustic handler. Include Staurosporine as a positive control (Reference Inhibitor).
- Enzyme Incubation: Add 5 L of Kinase Buffer. Incubate for 10 minutes to allow compound-enzyme equilibrium.
  - Expert Insight: This pre-incubation is critical for detecting slow-binding inhibitors.
- Reaction Initiation: Add 5 L of ATP/Substrate mix. The ATP concentration must be at the enzyme's to ensure the assay is sensitive to ATP-competitive inhibitors.
- Termination: After 60 minutes, add 5 L of Development Reagent (protease that cleaves non-phosphorylated peptides).
- Readout: Measure Fluorescence Ratio (Emission 445 nm / Emission 520 nm).

- Data Analysis: Calculate % Inhibition relative to DMSO controls.
  - Validation Criteria: Z-factor > 0.5; Staurosporine IC<sub>50</sub> within 2-fold of historical mean.

## Phase III: Secondary Cellular Assays

Objective: Confirm that enzymatic inhibition translates to cellular efficacy (antiproliferation) without non-specific toxicity.

### Protocol D: Resazurin Reduction Assay (Superior to MTT)

Why not MTT? Pyridine derivatives containing electron-deficient rings can chemically reduce MTT tetrazolium salts independent of cellular metabolism, causing false "viability" signals. Resazurin (Alamar Blue) is less prone to this chemical artifact.

Workflow:

- Seeding: Seed tumor cells (e.g., A549, MCF-7) at 3,000 cells/well in 96-well plates. Allow attachment for 24 hours.
- Treatment: Treat with serial dilutions of pyridine derivatives for 72 hours.
- Reagent Addition: Add Resazurin solution (final conc. 44 M).
- Incubation: Incubate for 1-4 hours. Viable cells reduce non-fluorescent Resazurin to fluorescent Resorufin.
- Detection: Measure Fluorescence (Ex 560 nm / Em 590 nm).
- Analysis: Plot Dose-Response curves. Compare cellular IC<sub>50</sub> to enzymatic IC<sub>50</sub>.
  - . A ratio >100 suggests poor permeability or efflux pump liability.

## Phase IV: ADME-Tox Profiling (The Safety Gate)

Critical Liability: Pyridines are notorious for inhibiting Cytochrome P450 (CYP) enzymes. The pyridine nitrogen can coordinate directly with the heme iron of the CYP active site, acting as a "Type II" ligand. This causes Drug-Drug Interactions (DDIs).[1]

### Diagram: The Screening Cascade

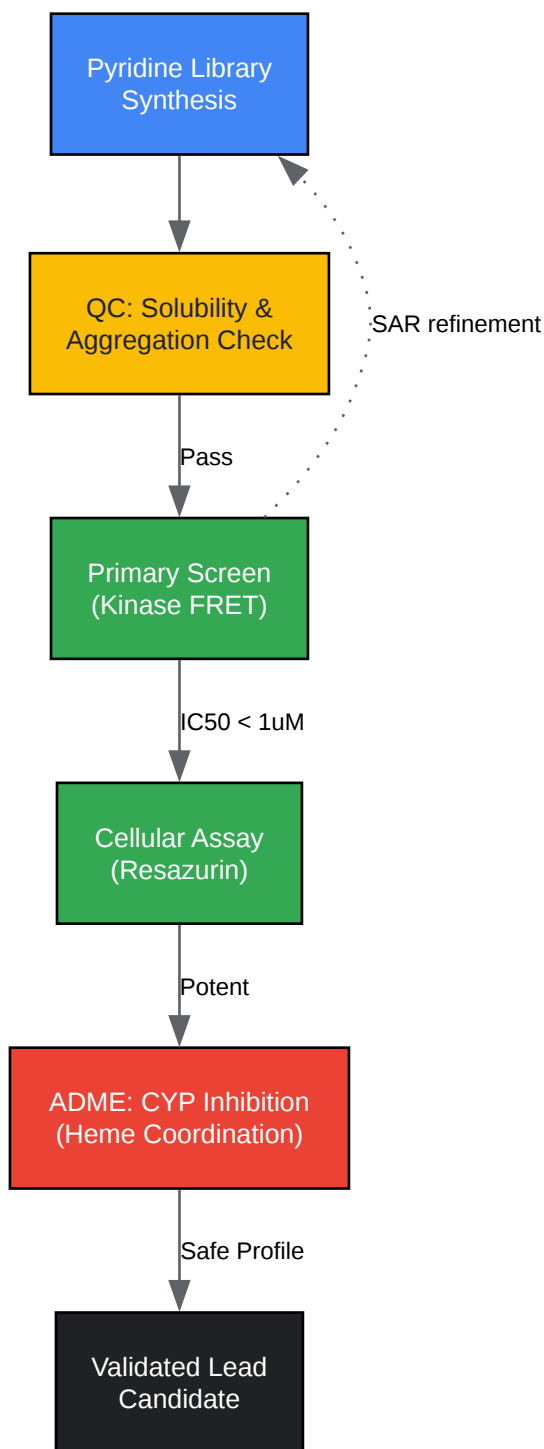

[Click to download full resolution via product page](#)

Caption: Integrated workflow from synthesis to lead validation, emphasizing the QC and Safety gates.

## Protocol E: CYP450 Spectral Binding Assay

Objective: Detect direct binding to the Heme iron (Type II binding spectrum).

- Microsome Prep: Use human liver microsomes (HLM) diluted to 1 mg/mL protein in phosphate buffer (pH 7.4).
- Baseline Scan: Record the UV-Vis spectrum (350–500 nm) of the microsomes alone.
- Titration: Add the pyridine derivative in stepwise increments (0.5

M to 50

M).

- Differential Scan: Record the spectrum after each addition.
  - Signature: Type II binding (Heme coordination) is characterized by a spectral trough at ~390 nm and a peak at ~425-430 nm.
- Risk Assessment: Compounds exhibiting strong Type II binding spectra are high-risk for potent CYP inhibition and should be optimized by sterically hindering the pyridine nitrogen or reducing its basicity.

## Summary of Key Parameters

Assay Type	Critical Parameter	Warning Sign (Flag)	Mitigation Strategy
Solubility	DMSO Tolerance	Visible precipitate upon dilution	Use HCl salt form; lower final concentration.
Enzymatic	Detergent Sensitivity	IC shifts >3x with Triton X-100	Compound is an aggregator. Discard or reformulate.
Cellular	Reagent Reduction	High background in "No Cell" wells	Switch from MTT to Resazurin or ATP-Glo.
ADME	Heme Binding	Peak at 425 nm (Type II Spectrum)	Steric hindrance near pyridine Nitrogen.

## References

- Mechanisms of CYP450 Inhibition. Encyclopedia.pub. Detailed overview of mechanism-based inhibition and heme coordination. [\[Link\]](#)
- Assay Interference by Aggregation. Assay Guidance Manual (NCBI). The authoritative protocol for detecting colloidal aggregators in HTS. [\[Link\]](#)
- Novel Biologically Active Pyridine Derivatives. ResearchGate. Review of antimicrobial and anticancer applications of pyridine scaffolds. [\[Link\]](#)
- Assay Interference by Chemical Reactivity. Assay Guidance Manual (NCBI). Discusses redox cycling and interference in viability assays (MTT artifacts). [\[Link\]](#)

### Need Custom Synthesis?

BenchChem offers custom synthesis for rare earth carbides and specific isotopic labeling.

Email: [info@benchchem.com](mailto:info@benchchem.com) or [Request Quote Online](#).

## Sources

- [1. semanticscholar.org \[semanticscholar.org\]](https://www.semanticscholar.org)
- To cite this document: BenchChem. [Application Note: Strategic Screening and Biological Profiling of Novel Pyridine Derivatives]. BenchChem, [2026]. [Online PDF]. Available at: [\[https://www.benchchem.com/product/b1279307/docs#application-note-strategic-screening-and-biological-profiling-of-novel-pyridine-derivatives\]](https://www.benchchem.com/product/b1279307/docs#application-note-strategic-screening-and-biological-profiling-of-novel-pyridine-derivatives)

### Disclaimer & Data Validity:

The information provided in this document is for Research Use Only (RUO) and is strictly not intended for diagnostic or therapeutic procedures. While BenchChem strives to provide accurate protocols, we make no warranties, express or implied, regarding the fitness of this product for every specific experimental setup.

**Technical Support:** The protocols provided are for reference purposes. Unsure if this reagent suits your experiment?

**Need Industrial/Bulk Grade?** [Request Custom Synthesis Quote](#)

## BenchChem

Our mission is to be the trusted global source of essential and advanced chemicals, empowering scientists and researchers to drive progress in science and industry.

### Contact

Address: 3281 E Guasti Rd  
Ontario, CA 91761, United States  
Phone: (601) 213-4426  
Email: [info@benchchem.com](mailto:info@benchchem.com)

[Contact our Ph.D. Support Team for a compatibility check](#)