

Technical Support Center: Boc Protection of Amino Acids

Author: BenchChem Technical Support Team. **Date:** May 2026

Compound of Interest

Compound Name:	1-((tert-butoxycarbonyl)amino)cyclopent-3-enecarboxylic acid
CAS No.:	213316-20-2
Cat. No.:	B1278404

[Get Quote](#)

This technical support center provides troubleshooting guides and frequently asked questions (FAQs) to address common side reactions encountered during the Boc protection of amino acids. The information is tailored for researchers, scientists, and professionals in drug development.

Frequently Asked Questions (FAQs)

Q1: What are the most common side reaction products observed during the Boc protection of amino acids?

The most frequently encountered side products include:

- N,N-di-Boc-amino acid: The formation of a second Boc group on the nitrogen atom of the primary amine.
- Urea derivatives: Formed especially with sterically hindered amines.[1]

- Oxazolidinone formation: An intramolecular cyclization product that can occur with β -amino alcohols like serine and threonine.
- Isocyanate formation: Can be a side reaction, particularly when using catalysts like 4-(dimethylamino)pyridine (DMAP) at low temperatures.[2][3]
- Dipeptide formation: The coupling of two amino acids can occur if the carboxylic acid is activated.

Q2: How can I prevent the formation of N,N-di-Boc-amino acid?

The formation of the di-Boc derivative is a common issue, especially when using a catalyst like DMAP or when the reaction conditions are too harsh.

Troubleshooting:

- Avoid DMAP for primary amines: For primary amino acids, avoid using DMAP as a catalyst, as it is known to promote the formation of di-Boc products.[1]
- Catalyst-free reaction in water: Performing the reaction in water without a catalyst can provide excellent chemoselectivity for mono-N-Boc protection and avoids side products like N,N-di-t-Boc derivatives.[4]
- Control stoichiometry: Use a slight excess (1.1-1.2 equivalents) of the Boc-protection reagent ((Boc)₂O). A large excess can increase the likelihood of di-protection.
- Reaction conditions: Conduct the reaction at room temperature or below. Elevated temperatures can favor over-reaction.

Table 1: Influence of Reaction Parameters on Di-Boc Formation

Parameter	Condition to Minimize Di-Boc	Rationale
Catalyst	Avoid DMAP; consider catalyst-free	DMAP is a highly effective acylation catalyst that can facilitate the second Boc addition.
Solvent	Water	Promotes selective mono-protection.[4]
Stoichiometry	1.1-1.2 eq. (Boc) ₂ O	Limits the availability of the reagent for a second reaction.
Temperature	Room temperature or 0 °C	Reduces the reaction rate, allowing for better control.

Q3: I am observing significant urea formation in my reaction with a sterically hindered amino acid. How can I avoid this?

Sterically hindered amines are more prone to react with (Boc)₂O to form urea byproducts.[1]

Troubleshooting:

- Use a strong, non-nucleophilic base: Deprotonate the amino acid first with a strong base like sodium hydride (NaH) or sodium hexamethyldisilazide (NaHMDS) before adding the (Boc)₂O.[1] This increases the nucleophilicity of the amine and favors the desired carbamylation over urea formation.
- Choice of Boc reagent: While (Boc)₂O is standard, for particularly challenging substrates, consider alternative reagents like Boc-ON, which can sometimes give cleaner reactions.[5]

Q4: While protecting serine/threonine, I am getting an unexpected byproduct. Could it be an oxazolidinone, and how can I prevent it?

Yes, amino acids with a hydroxyl group on the β-carbon, such as serine and threonine, can undergo intramolecular cyclization to form a 5-membered oxazolidinone ring.

Troubleshooting:

- Use of HFIP as solvent: The use of 1,1,1,3,3,3-hexafluoroisopropanol (HFIP) as a solvent and catalyst has been shown to prevent the formation of oxazolidinones from α -amino alcohols.[4]
- Catalyst-free conditions in water: Similar to preventing di-Boc formation, a catalyst-free reaction in water can also suppress oxazolidinone formation.[4]
- Protect the hydroxyl group: If other methods fail, consider protecting the side-chain hydroxyl group of serine or threonine prior to the Boc protection of the amine.

Experimental Protocols

Protocol 1: General Method for Selective Mono-N-Boc Protection in Water (to minimize Di-Boc, Urea, and Oxazolidinone formation)[4]

- Dissolution: Dissolve the amino acid (1.0 equivalent) in water.
- Base Addition: Add a suitable base such as sodium bicarbonate (NaHCO_3) or sodium hydroxide (NaOH) to adjust the pH to approximately 9-10.
- Reagent Addition: Add di-tert-butyl dicarbonate ($(\text{Boc})_2\text{O}$) (1.1 equivalents) portion-wise while stirring vigorously at room temperature.
- Reaction Monitoring: Monitor the reaction progress by TLC or LC-MS. The reaction is typically complete within 2-4 hours.
- Work-up:
 - Wash the reaction mixture with a non-polar organic solvent (e.g., hexane or diethyl ether) to remove any unreacted $(\text{Boc})_2\text{O}$.
 - Acidify the aqueous layer to pH 2-3 with a cold, dilute acid (e.g., 1 M HCl or citric acid).
 - Extract the product with an organic solvent (e.g., ethyl acetate).

- Dry the combined organic layers over anhydrous sodium sulfate or magnesium sulfate, filter, and concentrate under reduced pressure to yield the N-Boc-amino acid.

Protocol 2: Boc Protection of Sterically Hindered Amino Acids (to minimize urea formation)[1]

- Inert Atmosphere: In a flame-dried flask under an inert atmosphere (e.g., nitrogen or argon), suspend sodium hydride (NaH, 60% dispersion in mineral oil, 1.2 equivalents) in anhydrous tetrahydrofuran (THF).
- Amino Acid Addition: Add the sterically hindered amino acid (1.0 equivalent) portion-wise at 0 °C.
- Stirring: Allow the mixture to stir at room temperature for 30-60 minutes.
- Reagent Addition: Cool the reaction mixture back to 0 °C and add a solution of di-tert-butyl dicarbonate ((Boc)₂O) (1.1 equivalents) in anhydrous THF dropwise.
- Reaction Monitoring: Allow the reaction to warm to room temperature and stir overnight. Monitor the reaction progress by TLC or LC-MS.
- Work-up:
 - Carefully quench the reaction by the slow addition of water at 0 °C.
 - Adjust the pH to 2-3 with a cold, dilute acid.
 - Extract the product with an organic solvent.
 - Dry the combined organic layers, filter, and concentrate under reduced pressure.

Visualizations

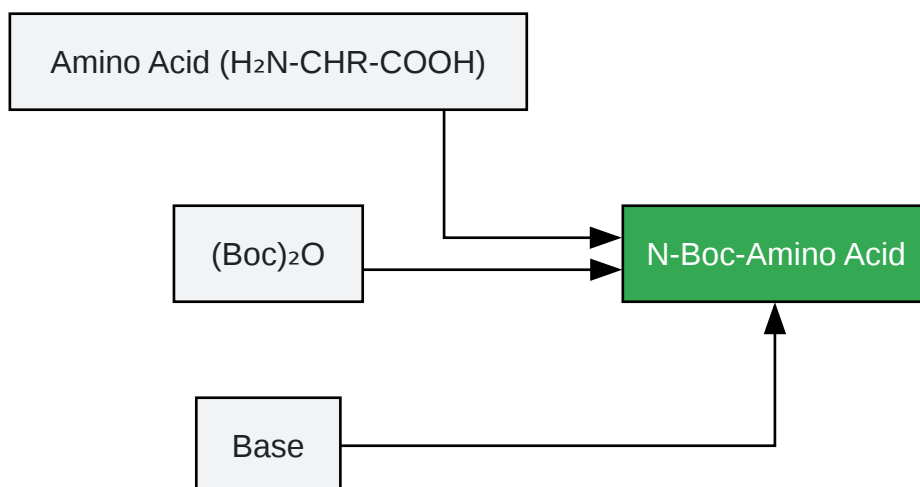

[Click to download full resolution via product page](#)

Caption: Main reaction pathway for Boc protection of an amino acid.

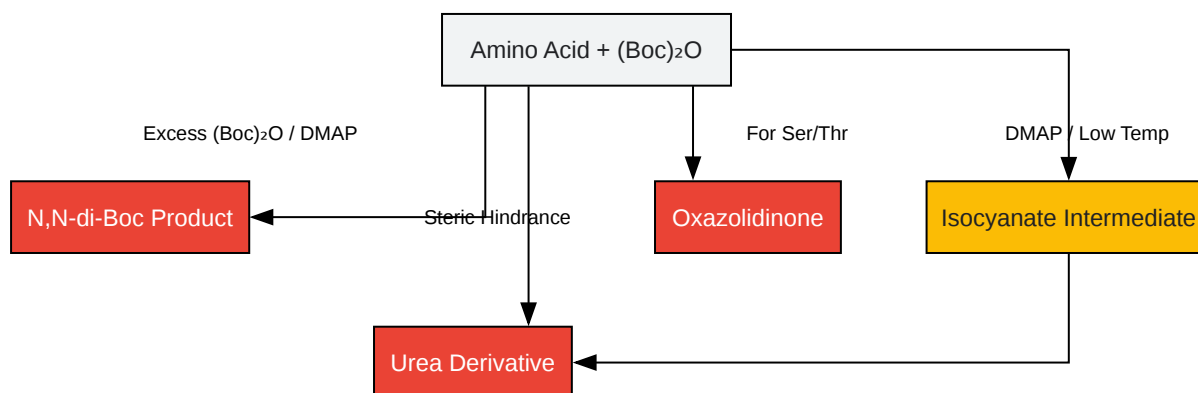

[Click to download full resolution via product page](#)

Caption: Common side reaction pathways in Boc protection.

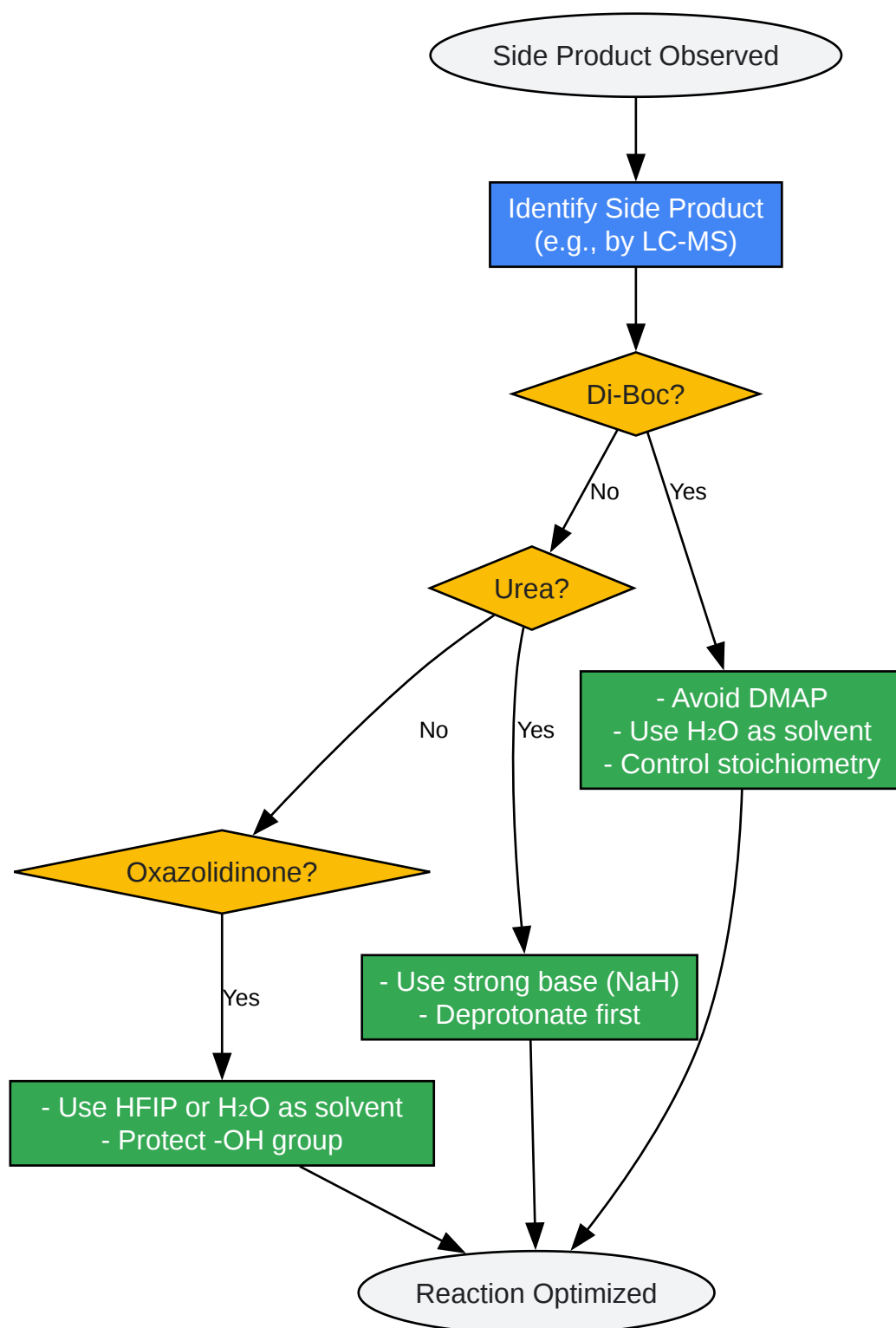

[Click to download full resolution via product page](#)

Caption: A logical workflow for troubleshooting side reactions.

Need Custom Synthesis?

BenchChem offers custom synthesis for rare earth carbides and specific isotopic labeling.

Email: info@benchchem.com or [Request Quote Online](#).

References

- [1. aapep.bocsci.com](http://aapep.bocsci.com) [aapep.bocsci.com]
- [2. Dual protection of amino functions involving Boc - RSC Advances \(RSC Publishing\)](#)
[DOI:10.1039/C3RA42956C](https://doi.org/10.1039/C3RA42956C) [pubs.rsc.org]
- [3. pubs.rsc.org](http://pubs.rsc.org) [pubs.rsc.org]
- [4. Boc-Protected Amino Groups](http://organic-chemistry.org) [organic-chemistry.org]
- [5. peptide.com](http://peptide.com) [peptide.com]
- To cite this document: BenchChem. [Technical Support Center: Boc Protection of Amino Acids]. BenchChem, [2026]. [Online PDF]. Available at:
[\[https://www.benchchem.com/product/b1278404/docs#technical-support-center-boc-protection-of-amino-acids\]](https://www.benchchem.com/product/b1278404/docs#technical-support-center-boc-protection-of-amino-acids)

Disclaimer & Data Validity:

The information provided in this document is for Research Use Only (RUO) and is strictly not intended for diagnostic or therapeutic procedures. While BenchChem strives to provide accurate protocols, we make no warranties, express or implied, regarding the fitness of this product for every specific experimental setup.

Technical Support: The protocols provided are for reference purposes. Unsure if this reagent suits your experiment?

Need Industrial/Bulk Grade? [Request Custom Synthesis Quote](#)

BenchChem

Our mission is to be the trusted global source of essential and advanced chemicals, empowering scientists and researchers to drive progress in science and industry.

Contact

Address: 3281 E Guasti Rd

Ontario, CA 91761, United States

Phone: (601) 213-4426

Email: info@benchchem.com

[Contact our Ph.D. Support Team for a compatibility check](#)