

Standard Operating Procedure for Boc-Asp-OMe Coupling Reactions

Author: BenchChem Technical Support Team. **Date:** April 2026

Compound of Interest

Compound Name: *Boc-Asp-OMe*

CAS No.: 98045-03-5

Cat. No.: B1278825

[Get Quote](#)

For Researchers, Scientists, and Drug Development Professionals

This document provides a detailed application note and protocol for the coupling of N- α -(tert-Butoxycarbonyl)-L-aspartic acid α -methyl ester (**Boc-Asp-OMe**) in peptide synthesis. This procedure is applicable for both solution-phase and solid-phase peptide synthesis (SPPS) with appropriate modifications.

Introduction

N- α -(tert-Butoxycarbonyl)-L-aspartic acid α -methyl ester (**Boc-Asp-OMe**) is a crucial building block in the synthesis of peptides and peptidomimetics.[1] The Boc protecting group on the α -amine allows for controlled, stepwise elongation of the peptide chain, while the methyl ester on the α -carboxyl group facilitates specific coupling reactions.[1][2] The choice of coupling reagent and reaction conditions is critical to ensure high yield and minimize side reactions, such as racemization.[3] This protocol outlines a standard procedure using common carbodiimide-based coupling reagents in the presence of an activating agent.

Data Summary

The efficiency of the coupling reaction is dependent on the choice of reagents and the specific substrate. The following table summarizes typical reaction parameters for the coupling of a Boc-protected amino acid like **Boc-Asp-OMe**.

Parameter	Condition	Typical Range	Notes
Boc-Asp-OMe	1.0 equivalent	-	The limiting reagent.
Amine Component	1.0 - 1.2 equivalents	-	Can be an amino acid ester or a resin-bound amine.
Coupling Reagent (e.g., DCC, EDC, DIC)	1.1 - 1.5 equivalents	-	Carbodiimides are common activators.[3] [4]
Additive/Activating Agent (e.g., HOBt)	1.1 - 1.5 equivalents	-	Suppresses racemization and improves efficiency.[3] [4][5]
Base (e.g., DIPEA, NMM)	1.0 - 2.0 equivalents	-	Required to neutralize amine salts and facilitate the reaction. [6]
Solvent	Anhydrous DCM or DMF	-	Choice depends on the solubility of reactants.[6][7]
Temperature	0 °C to Room Temperature	-	Initial cooling helps to control the reaction rate and minimize side reactions.[6]
Reaction Time	2 - 24 hours	-	Monitored by TLC or other analytical methods.[6]
Typical Yield	>85%	-	Highly dependent on substrates and reaction conditions.

Experimental Protocols

This section details the methodologies for solution-phase and solid-phase **Boc-Asp-OMe** coupling reactions.

Solution-Phase Peptide Synthesis Protocol

This protocol describes the coupling of **Boc-Asp-OMe** to an amino acid methyl ester hydrochloride (e.g., H-Gly-OMe·HCl) as a representative amine component.

Materials:

- **Boc-Asp-OMe**
- Amino acid methyl ester hydrochloride (e.g., Glycine methyl ester hydrochloride)
- N,N'-Dicyclohexylcarbodiimide (DCC) or N-(3-Dimethylaminopropyl)-N'-ethylcarbodiimide hydrochloride (EDC)[6]
- 1-Hydroxybenzotriazole (HOBt)[6]
- Diisopropylethylamine (DIPEA) or N-Methylmorpholine (NMM)[6]
- Anhydrous Dichloromethane (DCM) or N,N-Dimethylformamide (DMF)[6]
- Ethyl acetate (EtOAc)
- 1M Hydrochloric acid (HCl)
- Saturated aqueous sodium bicarbonate (NaHCO₃) solution
- Brine (saturated aqueous NaCl)
- Anhydrous magnesium sulfate (MgSO₄) or sodium sulfate (Na₂SO₄)

Procedure:

- Preparation of the Amine Component:
 - Dissolve the amino acid methyl ester hydrochloride (1.0 equivalent) in anhydrous DCM.[6]

- Add DIPEA or NMM (1.1 equivalents) to neutralize the hydrochloride salt and stir for 10-15 minutes at room temperature.[6]
- Activation of the Carboxyl Component:
 - In a separate flask, dissolve **Boc-Asp-OMe** (1.0 equivalent) and HOBt (1.1 equivalents) in anhydrous DCM.[6]
 - Cool the solution to 0 °C in an ice bath.[6]
 - Add DCC or EDC (1.1 equivalents) to the solution and stir for 20-30 minutes at 0 °C. If using DCC, a white precipitate of dicyclohexylurea (DCU) will form.[6]
- Coupling Reaction:
 - Add the prepared amine solution from step 1 to the activated carboxyl component solution at 0 °C.[6]
 - Allow the reaction mixture to slowly warm to room temperature and stir for 12-24 hours.[6]
- Reaction Monitoring:
 - Monitor the progress of the reaction by Thin-Layer Chromatography (TLC) by observing the consumption of the starting materials.[8]
- Work-up and Purification:
 - If DCC was used, filter the reaction mixture to remove the precipitated DCU.[6]
 - Dilute the filtrate with ethyl acetate.[6]
 - Wash the organic layer sequentially with 1M HCl (2x), saturated aqueous NaHCO₃ solution (2x), and brine (1x).[6]
 - Dry the organic layer over anhydrous MgSO₄ or Na₂SO₄, filter, and concentrate under reduced pressure.[6]
 - The crude product can be purified by flash column chromatography on silica gel.[6]

Solid-Phase Peptide Synthesis (SPPS) Protocol

This protocol outlines the coupling of **Boc-Asp-OMe** to a resin-bound amine.

Materials:

- Boc-protected peptide-resin
- Trifluoroacetic acid (TFA)
- **Boc-Asp-OMe**
- N,N'-Diisopropylcarbodiimide (DIC)[7]
- 1-Hydroxybenzotriazole (HOBt)[7]
- Diisopropylethylamine (DIPEA)[7]
- Anhydrous Dichloromethane (DCM)[7]
- Anhydrous N,N-Dimethylformamide (DMF)[7]
- Ninhydrin test kit[6]

Procedure:

- Resin Swelling and Deprotection:
 - Swell the peptide-resin in DCM for 30 minutes.
 - To deprotect the N-terminal Boc group, treat the resin with a solution of 50% TFA in DCM for 30 minutes.[7]
 - Wash the resin thoroughly with DCM (3x) and DMF (3x).[6]
- Neutralization:
 - Treat the resin with a solution of 5% DIPEA in DMF for 5-10 minutes to neutralize the trifluoroacetate salt of the N-terminal amine.[6]

- Wash the resin with DMF (3x) to remove excess base.[6]
- Activation of **Boc-Asp-OMe**:
 - In a separate vessel, dissolve **Boc-Asp-OMe** (2-4 equivalents relative to resin loading) and HOBt (2-4 equivalents) in DMF.[6]
 - Add DIC (2-4 equivalents) to the solution and allow it to activate for 10-15 minutes at room temperature.[6]
- Coupling Reaction:
 - Add the activated **Boc-Asp-OMe** solution to the neutralized peptide-resin.[6]
 - Agitate the reaction mixture at room temperature for 2-4 hours.[6]
- Monitoring the Coupling Reaction:
 - Take a small sample of the resin beads, wash them thoroughly, and perform a ninhydrin test.[6] A negative result (no color change or a faint yellow) indicates complete coupling.[6] If the test is positive, the coupling reaction can be extended or repeated.[6]
- Washing:
 - Once the coupling is complete, filter the reaction mixture and wash the peptide-resin thoroughly with DMF (3x) and DCM (3x) to remove excess reagents and byproducts.[6]

Visualizations

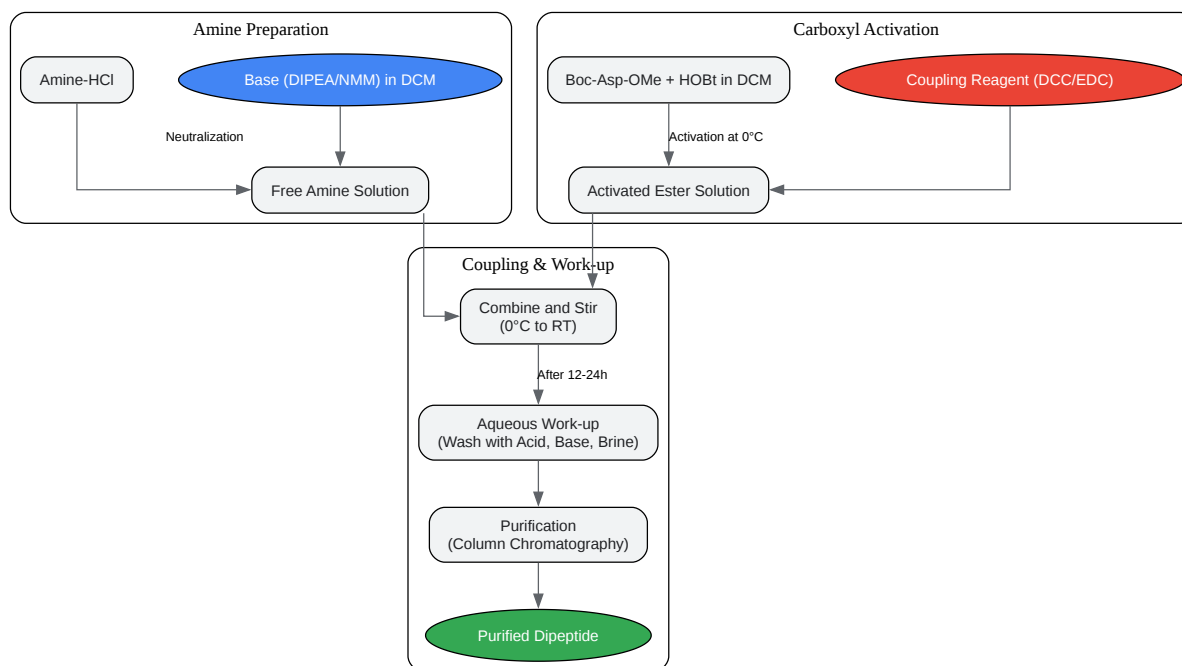

[Click to download full resolution via product page](#)

Caption: Workflow for solution-phase **Boc-Asp-OMe** coupling.

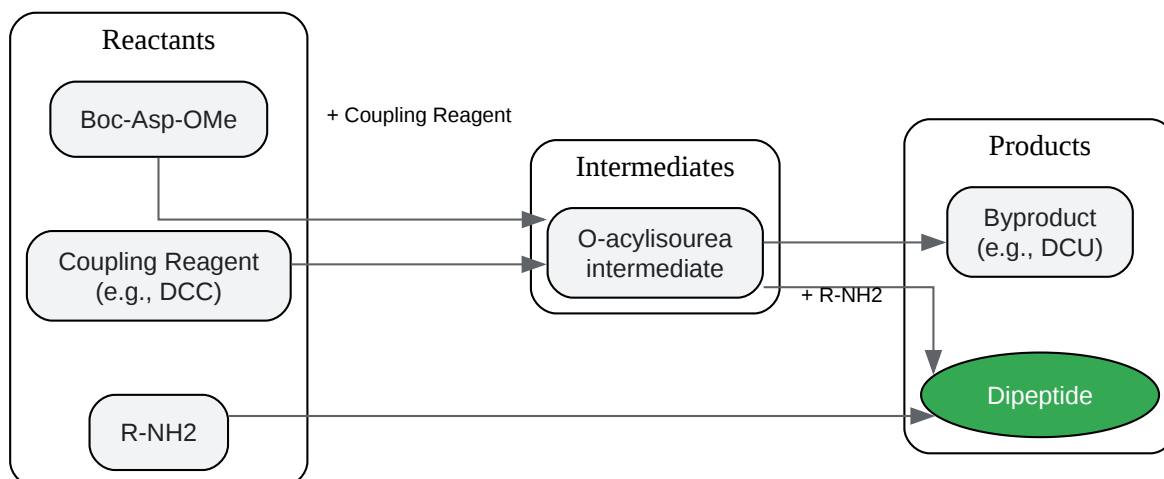

[Click to download full resolution via product page](#)

Caption: Chemical pathway for carbodiimide-mediated coupling.

Need Custom Synthesis?

BenchChem offers custom synthesis for rare earth carbides and specific isotopic labeling.

Email: info@benchchem.com or [Request Quote Online](#).

References

- 1. chemimpex.com [chemimpex.com]
- 2. nbinno.com [nbinno.com]
- 3. bachem.com [bachem.com]
- 4. merckmillipore.com [merckmillipore.com]
- 5. pubs.acs.org [pubs.acs.org]
- 6. benchchem.com [benchchem.com]
- 7. peptide.com [peptide.com]
- 8. benchchem.com [benchchem.com]

- To cite this document: BenchChem. [Standard Operating Procedure for Boc-Asp-OMe Coupling Reactions]. BenchChem, [2026]. [Online PDF]. Available at: [\[https://www.benchchem.com/product/b1278825/docs#standard-operating-procedure-for-boc-asp-ome-coupling-reactions\]](https://www.benchchem.com/product/b1278825/docs#standard-operating-procedure-for-boc-asp-ome-coupling-reactions)

Disclaimer & Data Validity:

The information provided in this document is for Research Use Only (RUO) and is strictly not intended for diagnostic or therapeutic procedures. While BenchChem strives to provide accurate protocols, we make no warranties, express or implied, regarding the fitness of this product for every specific experimental setup.

Technical Support: The protocols provided are for reference purposes. Unsure if this reagent suits your experiment?

Need Industrial/Bulk Grade? [Request Custom Synthesis Quote](#)

BenchChem

Our mission is to be the trusted global source of essential and advanced chemicals, empowering scientists and researchers to drive progress in science and industry.

Contact

Address: 3281 E Guasti Rd
Ontario, CA 91761, United States
Phone: (601) 213-4426
Email: info@benchchem.com

[Contact our Ph.D. Support Team for a compatibility check](#)