

Technical Support Center: Investigating the mTOR Signaling Pathway

Author: BenchChem Technical Support Team. **Date:** April 2026

Compound of Interest

Compound Name: Torrat
CAS No.: 72416-03-6
Cat. No.: B12777964

[Get Quote](#)

This guide provides troubleshooting advice and frequently asked questions (FAQs) to address common pitfalls encountered when studying the mechanistic target of rapamycin (mTOR) signaling pathway. The information is tailored for researchers, scientists, and drug development professionals to help ensure robust and reliable experimental outcomes.

Frequently Asked Questions (FAQs)

FAQ 1: What are the key differences between mTORC1 and mTORC2, and how do they affect experimental design?

The mammalian target of rapamycin (mTOR) kinase is the core component of two distinct protein complexes, mTOR Complex 1 (mTORC1) and mTOR Complex 2 (mTORC2).[1][2] Understanding their unique compositions, functions, and sensitivities to inhibitors is critical for designing and interpreting experiments.

- mTORC1 is a central regulator of cell growth and metabolism, integrating signals from growth factors, amino acids, energy levels, and oxygen.[2][3] It promotes anabolic processes

like protein and lipid synthesis while inhibiting catabolic processes like autophagy.[2] A key characteristic of mTORC1 is its acute sensitivity to the allosteric inhibitor rapamycin.[4]

- mTORC2 is generally insensitive to acute rapamycin treatment and is involved in cell survival, cytoskeletal organization, and metabolism.[1][4] It activates downstream kinases such as Akt, PKC α , and SGK1.[2]

Your experimental design must account for these differences. For instance, if you are specifically investigating mTORC1 activity, rapamycin can be a useful tool. However, to probe the functions of mTORC2 or the complete kinase activity of mTOR, ATP-competitive inhibitors are necessary.

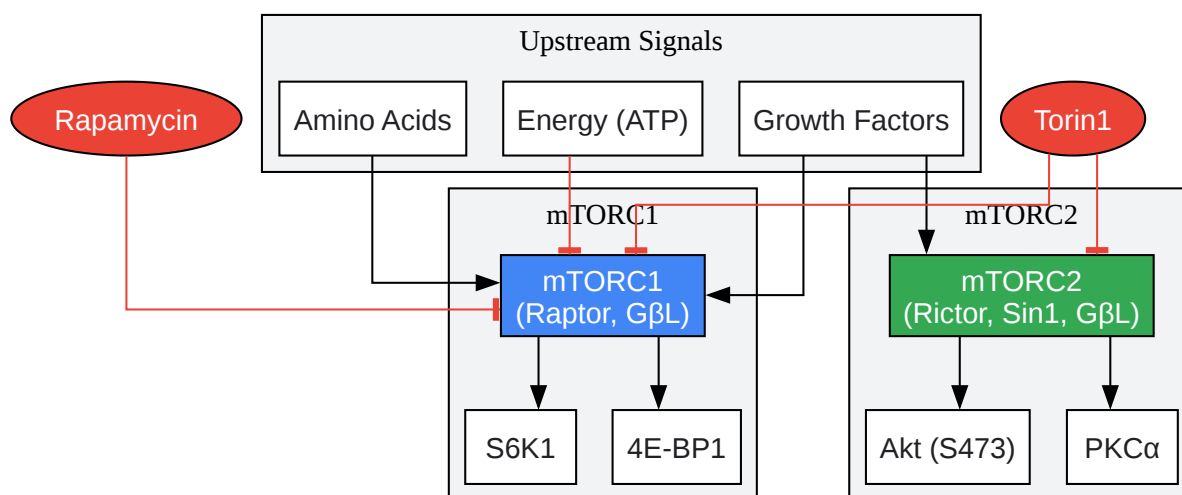

[Click to download full resolution via product page](#)

Figure 1: Simplified overview of mTORC1 and mTORC2 pathways and inhibitor targets.

FAQ 2: I treated my cells with rapamycin but still see some phosphorylation of 4E-BP1. Is the inhibitor not working?

This is a common and important observation. While rapamycin is a potent inhibitor of mTORC1, it does not completely block the phosphorylation of all mTORC1 substrates, most notably 4E-BP1.[5]

Rapamycin works allosterically by binding to FKBP12, and this complex then binds to the FRB domain of mTOR, which is thought to prevent access for only a subset of mTORC1 substrates. [5]

- Rapamycin-Sensitive Sites: Phosphorylation of S6K1 at Threonine 389 (T389) and 4E-BP1 at Serine 65 (S65) are generally considered sensitive to rapamycin.[6]
- Rapamycin-Resistant Sites: Phosphorylation of 4E-BP1 at Threonine 37 (T37) and Threonine 46 (T46) is largely resistant to rapamycin.[5]

To achieve complete inhibition of 4E-BP1 phosphorylation and other rapamycin-resistant mTORC1 functions, an ATP-competitive mTOR kinase inhibitor, such as Torin1, is required.[5] Therefore, your rapamycin is likely working as expected, but you are observing a known limitation of its mechanism.

FAQ 3: What is the difference between rapamycin and ATP-competitive inhibitors like Torin1?

The primary difference lies in their mechanism of action and their target spectrum.

Feature	Rapamycin (and its analogs)	Torin1 (and other ATP-competitive inhibitors)
Mechanism	Allosteric inhibitor; forms a complex with FKBP12 to bind mTOR's FRB domain.[1]	ATP-competitive inhibitor; binds directly to the mTOR kinase domain.[5]
Target	Acutely inhibits mTORC1.[4] Prolonged exposure may affect mTORC2 assembly in some cell types.[4]	Directly inhibits the kinase activity of both mTORC1 and mTORC2.[5]
Effect on 4E-BP1	Incomplete inhibition; p-T37/T46 are largely resistant.[5]	Complete inhibition of all phosphorylation sites.[5]
Effect on Cell Proliferation	Moderate inhibition.[7]	Potent inhibition.[5][7]

Table 1: Comparison of mTOR Inhibitors.

Researchers should choose an inhibitor based on the specific question being asked. Use rapamycin to specifically probe rapamycin-sensitive mTORC1 functions, and use ATP-competitive inhibitors to study the full range of mTORC1 and mTORC2 activities.

Western Blotting Troubleshooting Guide

Western blotting is the most common technique for assessing mTOR pathway activity by measuring the phosphorylation status of key downstream proteins.[1]

Problem 1: Weak or No Signal for Phospho-Proteins

A lack of signal is a frequent issue, often stemming from sample preparation or antibody issues.

Possible Causes & Solutions:

- **Protein Degradation/Dephosphorylation:** Phosphatases and proteases released during cell lysis can quickly remove phosphate groups and degrade proteins.

- Solution: Always use a lysis buffer freshly supplemented with a cocktail of protease and phosphatase inhibitors.[\[1\]](#)[\[8\]](#) Keep samples on ice at all times.[\[1\]](#)[\[8\]](#)
- Insufficient Protein Loaded: mTOR pathway proteins can have low basal expression.
 - Solution: Ensure you load an adequate amount of protein, typically 20-40 µg of lysate per lane.[\[1\]](#)[\[9\]](#) For low-abundance targets, this may need to be increased.[\[9\]](#)
- Inefficient Protein Transfer: Large proteins like mTOR (~289 kDa) can be difficult to transfer efficiently.
 - Solution: Use a wet transfer system, optimize transfer time and voltage, and consider adding a low concentration of SDS (e.g., 0.05%) to the transfer buffer for high molecular weight proteins.[\[1\]](#)
- Suboptimal Antibody Dilution/Incubation:
 - Solution: Increase the primary antibody concentration or extend the incubation time (e.g., overnight at 4°C).[\[10\]](#)[\[11\]](#)

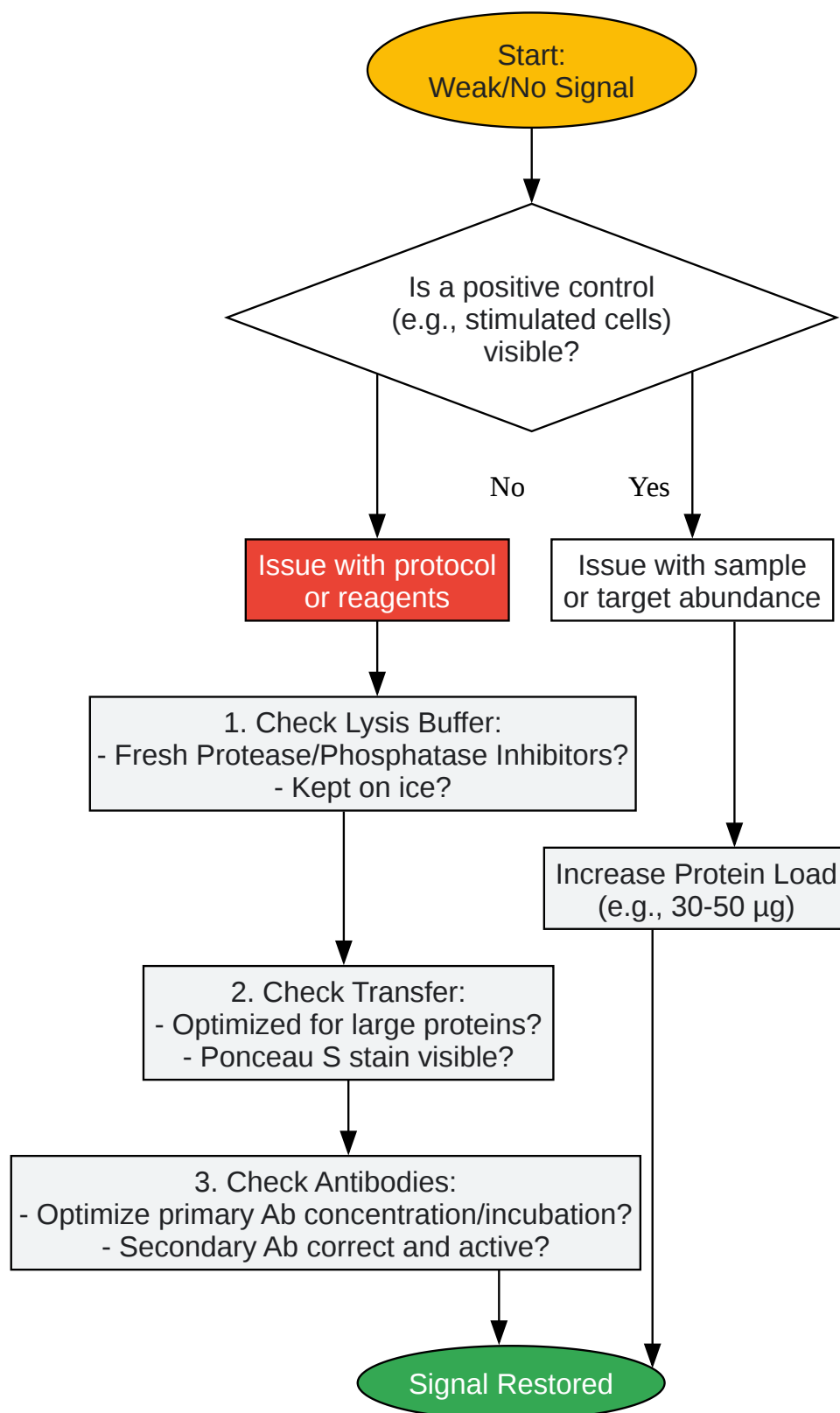

[Click to download full resolution via product page](#)

Figure 2: Troubleshooting workflow for weak or no signal in mTOR Western Blots.

Problem 2: High Background or Non-Specific Bands

High background can obscure results and make quantification unreliable.

Possible Causes & Solutions:

- Insufficient Blocking: The membrane has unbound sites that antibodies can adhere to non-specifically.
 - Solution: Increase blocking time to 1 hour at room temperature.^[1] Consider switching blocking agents; for phospho-antibodies, Bovine Serum Albumin (BSA) is often preferred over non-fat dry milk, as milk contains phosphoproteins that can cause background.^[11]
- Antibody Concentration Too High:
 - Solution: Decrease the concentration of the primary or secondary antibody.^[11]
- Inadequate Washing:
 - Solution: Increase the number and duration of washing steps with TBST between antibody incubations.^[1]

Problem 3: Interpreting Phosphorylation Shifts of 4E-BP1

4E-BP1 appears as multiple bands on a Western blot due to its hierarchical phosphorylation, which can be confusing to interpret.

- Band Identification: 4E-BP1 typically resolves into three bands, often labeled α , β , and γ .^[12]
 - γ -form (uppermost band): Hyperphosphorylated, inactive form (dissociated from eIF4E).
 - β -form (middle band): Intermediately phosphorylated.
 - α -form (lowest band): Hypophosphorylated or unphosphorylated, active form (bound to eIF4E).

- Interpretation: The "band shift" is a key indicator of mTORC1 activity. Upon mTORC1 activation (e.g., by insulin stimulation), the lower α and β bands should decrease in intensity while the upper γ band increases. Conversely, mTORC1 inhibition (e.g., with Torin1) will cause a shift down, with an increase in the α and β forms.[13]
- Quantification: To quantify 4E-BP1 phosphorylation, you can measure the ratio of the hyperphosphorylated (γ) band to the total 4E-BP1 signal (sum of all bands).[14] Alternatively, using phospho-specific antibodies for sites like T37/T46 provides a more direct readout of mTOR-dependent phosphorylation.[14]

Key Experimental Protocols

Protocol 1: Cell Lysis for Phospho-Protein Analysis

This protocol is designed to preserve the phosphorylation status of mTOR pathway proteins.

- Preparation: Prepare a lysis buffer (e.g., RIPA or NP-40 buffer) and place it on ice.[1][8] Just before use, add a protease inhibitor cocktail and a phosphatase inhibitor cocktail to the buffer.[1][8]
- Cell Harvest: Place the cell culture dish on ice and wash cells twice with ice-cold PBS.[1]
- Lysis: Aspirate the PBS completely. Add 100-200 μ L of ice-cold lysis buffer to the dish.[1]
- Scraping: Using a cell scraper, scrape the cells into the lysis buffer and transfer the lysate to a pre-chilled microcentrifuge tube.[1][8]
- Incubation: Incubate the lysate on ice for 30 minutes, vortexing occasionally.[1]
- Clarification: Centrifuge the lysate at 14,000 x g for 15 minutes at 4°C to pellet cell debris.[1]
- Collection: Carefully transfer the supernatant (containing soluble proteins) to a new pre-chilled tube.
- Quantification: Determine the protein concentration using a detergent-compatible assay like BCA.[1]
- Storage: Store lysates at -80°C for long-term use.

Protocol 2: In Vitro mTORC1 Kinase Assay

This assay directly measures the kinase activity of immunoprecipitated mTORC1.

- Cell Lysis: Lyse stimulated cells (e.g., insulin-treated) in a CHAPS-containing lysis buffer, which is crucial for maintaining the integrity of the mTORC1 complex.[15][16]
- Immunoprecipitation (IP): Incubate the cell lysate with an antibody against an mTORC1 component (e.g., anti-Raptor or anti-mTOR) for 1.5-2 hours at 4°C.[15]
- Bead Capture: Add Protein A/G agarose beads and incubate for another hour at 4°C to capture the antibody-mTORC1 complexes.[10]
- Washing: Wash the immunoprecipitates multiple times with wash buffers to remove non-specific binders. A high-salt wash can be included to remove inhibitors like PRAS40.[17]
- Kinase Reaction:
 - Resuspend the beads in a kinase assay buffer.
 - Add a purified substrate (e.g., recombinant GST-4E-BP1 or GST-S6K1) and ATP.[15][18]
 - To enhance activity, purified active Rheb-GTP can be added to the reaction.[15]
- Incubation: Incubate the reaction at 30°C for 30-60 minutes with shaking.[15]
- Termination: Stop the reaction by adding SDS-PAGE sample buffer and boiling at 95-100°C for 5 minutes.[15]
- Analysis: Analyze the reaction products by Western blotting using a phospho-specific antibody for the substrate (e.g., anti-phospho-4E-BP1 T37/46).[15]

Need Custom Synthesis?

BenchChem offers custom synthesis for rare earth carbides and specific isotopic labeling.

Email: info@benchchem.com or [Request Quote Online](#).

References

- [1. benchchem.com \[benchchem.com\]](#)
- [2. mTOR Signaling | Cell Signaling Technology \[cellsignal.com\]](#)
- [3. mTOR signaling at a glance - PMC \[pmc.ncbi.nlm.nih.gov\]](#)
- [4. Towards specific inhibition of mTORC2 - PMC \[pmc.ncbi.nlm.nih.gov\]](#)
- [5. An ATP-competitive Mammalian Target of Rapamycin Inhibitor Reveals Rapamycin-resistant Functions of mTORC1 - PMC \[pmc.ncbi.nlm.nih.gov\]](#)
- [6. Common corruption of the mTOR signaling network in human tumors - PMC \[pmc.ncbi.nlm.nih.gov\]](#)
- [7. researchgate.net \[researchgate.net\]](#)
- [8. Cell lysis and immunoblotting for protein and phospho-protein quantification \[protocols.io\]](#)
- [9. Western Blotting Troubleshooting Guide | Cell Signaling Technology \[cellsignal.com\]](#)
- [10. ccrod.cancer.gov \[ccrod.cancer.gov\]](#)
- [11. ウェスタンブロッティング トラブルシューティング | Thermo Fisher Scientific - JP \[thermofisher.com\]](#)
- [12. Hierarchical phosphorylation of the translation inhibitor 4E-BP1 - PMC \[pmc.ncbi.nlm.nih.gov\]](#)
- [13. 4E-BP1, a repressor of mRNA translation, is phosphorylated and inactivated by the Akt\(PKB\) signaling pathway - PMC \[pmc.ncbi.nlm.nih.gov\]](#)
- [14. researchgate.net \[researchgate.net\]](#)
- [15. bio-protocol.org \[bio-protocol.org\]](#)
- [16. en.bio-protocol.org \[en.bio-protocol.org\]](#)
- [17. researchgate.net \[researchgate.net\]](#)
- [18. Evaluating the mTOR Pathway in Physiological and Pharmacological Settings - PMC \[pmc.ncbi.nlm.nih.gov\]](#)
- To cite this document: BenchChem. [Technical Support Center: Investigating the mTOR Signaling Pathway]. BenchChem, [2026]. [Online PDF]. Available at: [\[https://www.benchchem.com/product/b12777964/docs#technical-support-center-investigating-the-mtor-signaling-pathway\]](https://www.benchchem.com/product/b12777964/docs#technical-support-center-investigating-the-mtor-signaling-pathway)

Disclaimer & Data Validity:

The information provided in this document is for Research Use Only (RUO) and is strictly not intended for diagnostic or therapeutic procedures. While BenchChem strives to provide accurate protocols, we make no warranties, express or implied, regarding the fitness of this product for every specific experimental setup.

Technical Support: The protocols provided are for reference purposes. Unsure if this reagent suits your experiment?

Need Industrial/Bulk Grade? [Request Custom Synthesis Quote](#)

BenchChem

Our mission is to be the trusted global source of essential and advanced chemicals, empowering scientists and researchers to drive progress in science and industry.

Contact

Address: 3281 E Guasti Rd
Ontario, CA 91761, United States
Phone: (601) 213-4426
Email: info@benchchem.com

[Contact our Ph.D. Support Team for a compatibility check](#)