

Comparative Analysis of Catalysts for 5-Bromoindole Coupling

Author: BenchChem Technical Support Team. **Date:** May 2026

Compound of Interest

Compound Name: 5-Bromo-1-isopropyl-1H-indole

CAS No.: 675827-10-8

Cat. No.: B1276853

[Get Quote](#)

Executive Summary

5-Bromoindole is a "privileged scaffold" in medicinal chemistry, serving as the core for numerous kinase inhibitors (e.g., Sunitinib analogues) and GPCR modulators. Its functionalization at the C5 position is primarily achieved via Palladium-catalyzed cross-coupling. However, the indole moiety presents unique challenges: the acidic N-H proton (pKa ~17), the electron-rich C3 position prone to side reactions, and the potential for catalyst poisoning by the nitrogen lone pair.

This guide objectively compares catalytic systems for C-C (Suzuki-Miyaura) and C-N (Buchwald-Hartwig) couplings at the C5 position. It moves beyond "legacy" catalysts like Pd(PPh₃)₄, highlighting modern precatalysts (Buchwald G3/G4) and NHC-complexes (PEPPSI) that offer superior turnover numbers (TON) and milder conditions.

Mechanistic Landscape

The efficiency of 5-bromoindole coupling is dictated by the Oxidative Addition step.^[1] The electron-rich nature of the indole ring makes the C5-Br bond less electrophilic than a standard

aryl bromide. Consequently, electron-rich, bulky ligands are required to facilitate this step while preventing catalyst deactivation.

Figure 1: Catalytic Cycle & Indole Electronics

The following diagram illustrates the catalytic cycle, emphasizing the critical oxidative addition step and the competing electronic effects of the indole core.

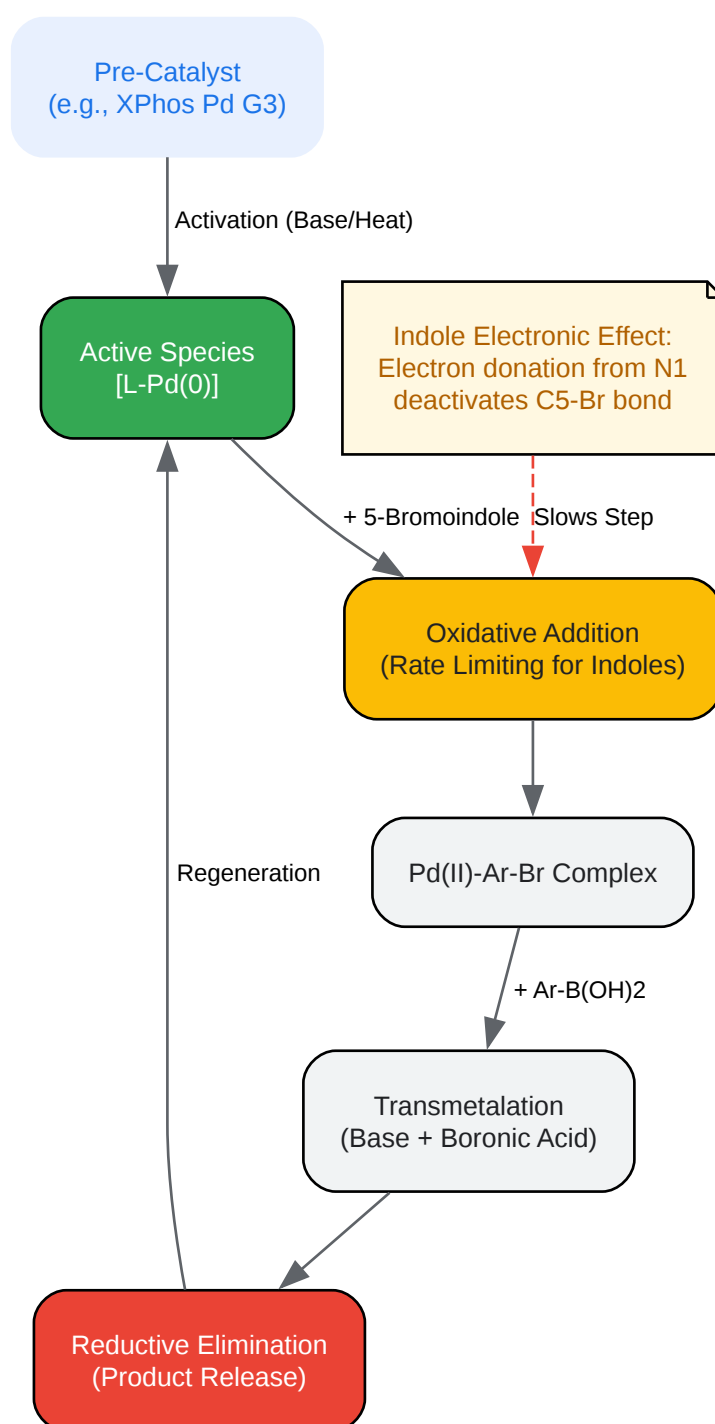

[Click to download full resolution via product page](#)

Caption: The Pd(0)/Pd(II) catalytic cycle. Note that the electron-donating nitrogen at position 1 increases electron density at C5, making the C-Br bond less reactive toward oxidative addition compared to electron-poor aryl halides.

Comparative Analysis: Suzuki-Miyaura Coupling

For C-C bond formation, three distinct catalyst classes dominate the literature. The choice depends on the stability of the boronic acid and the presence of sensitive functional groups.

Table 1: Catalyst Performance Matrix (C-C Coupling)

Feature	Pd(dppf)Cl ₂ (The Workhorse)	XPhos Pd G3/G4 (The Speedster)	Pd(PPh ₃) ₄ (The Legacy)
Primary Use Case	Robust coupling of standard aryl boronic acids.	Sterically hindered substrates; unstable boronic acids; low temp.	Simple, non-hindered substrates (Academic standard).
Typical Yield	75 - 90%	85 - 98%	50 - 70%
Reaction Temp	80°C - 100°C	RT - 40°C	80°C - 110°C
Air Stability	High	High (Precatalyst is stable)	Low (Oxidizes rapidly)
Limitations	Slow with sterically hindered partners. Requires heat.[2][3]	Higher cost.[4]	Poor TON; "Pd black" precipitation common.
Key Advantage	Reliability. Excellent for scale-up due to cost/stability balance.	Activity. Can couple heteroaryl chlorides/bromides in <30 mins.	Low cost; widely available.

Expert Insight:

- Recommendation: For routine screening, start with Pd(dppf)Cl₂. Its bidentate ligand prevents β-hydride elimination (if alkyl groups are present) and is robust against air.
- Optimization: If yields are <50% or the boronic acid is prone to protodeboronation (common with 2-heteroaryl boronic acids), switch immediately to XPhos Pd G3. The rapid oxidative addition facilitated by the bulky biaryl phosphine allows the reaction to proceed at temperatures low enough to preserve the boronic acid.

Comparative Analysis: Buchwald-Hartwig Amination

Creating C-N bonds at C5 is more sensitive to steric and electronic matching between the ligand and the amine nucleophile.

The "Ligand-Matching" Rule

Unlike Suzuki coupling, there is no "universal" catalyst for amination. You must match the ligand to the amine class:

- Primary Amines (R-NH₂): Use BrettPhos Pd G3/G4.
 - Why: BrettPhos is designed to prevent the binding of the smaller primary amine from inhibiting the catalyst, while promoting reductive elimination.
- Secondary Amines (R₂NH): Use RuPhos Pd G3/G4.
 - Why: RuPhos provides the necessary steric bulk to facilitate the reductive elimination of the bulky tertiary amine product.
- Base-Sensitive Substrates: Use GPhos Pd G6.
 - Why: Allows the use of mild bases (like NaOTMS) at 40°C, preventing side reactions on the indole ring.

Experimental Protocols

These protocols are designed to be self-validating. If the color changes described do not occur, check reagent quality (especially the Pd source).

Protocol A: Robust Suzuki Coupling (Pd(dppf)Cl₂ System)

Best for: Standard library synthesis, scale-up.

Reagents:

- 5-Bromoindole (1.0 equiv)
- Arylboronic acid (1.2 - 1.5 equiv)
- Catalyst: Pd(dppf)Cl₂[5][6][7]·CH₂Cl₂ (3-5 mol%)
- Base: K₂CO₃ (2.0 M aq. solution, 3.0 equiv)
- Solvent: 1,4-Dioxane (0.1 - 0.2 M concentration)

Procedure:

- Setup: Charge a reaction vial with 5-bromoindole, boronic acid, and Pd(dppf)Cl₂. Seal and purge with N₂/Ar for 5 mins. Note: The solid mix should be orange/red.
- Solvent Addn: Add degassed 1,4-dioxane and the aqueous K₂CO₃ solution via syringe.
- Reaction: Heat to 80°C for 2–4 hours. The mixture typically turns dark brown/black upon completion.
- Workup: Cool to RT. Dilute with EtOAc, wash with water and brine. Dry over MgSO₄.
- Purification: Flash chromatography (Hexane/EtOAc).

Protocol B: High-Efficiency Amination (RuPhos Pd G4 System)

Best for: Coupling secondary amines (e.g., Morpholine, Piperazine).

Reagents:

- 5-Bromoindole (1.0 equiv)
- Secondary Amine (1.2 equiv)
- Catalyst: RuPhos Pd G4 (1-2 mol%)
- Base: NaOtBu (Sodium tert-butoxide) (1.5 equiv)
- Solvent: Anhydrous Toluene or THF (degassed)

Procedure:

- Setup: In a glovebox or under strict Ar flow, add RuPhos Pd G4, NaOtBu, and 5-bromoindole to a vial.
- Addition: Add the amine and solvent.
- Reaction: Stir at 80°C (or 100°C for difficult substrates) for 1–12 hours.
 - Checkpoint: The G4 precatalyst activates rapidly; the solution should become homogeneous quickly before potentially darkening.
- Workup: Filter through a Celite pad (eluting with EtOAc) to remove insoluble salts and Pd residues. Concentrate and purify.

Decision Guide for Catalyst Selection

Use this logic tree to select the optimal system for your specific coupling partner.

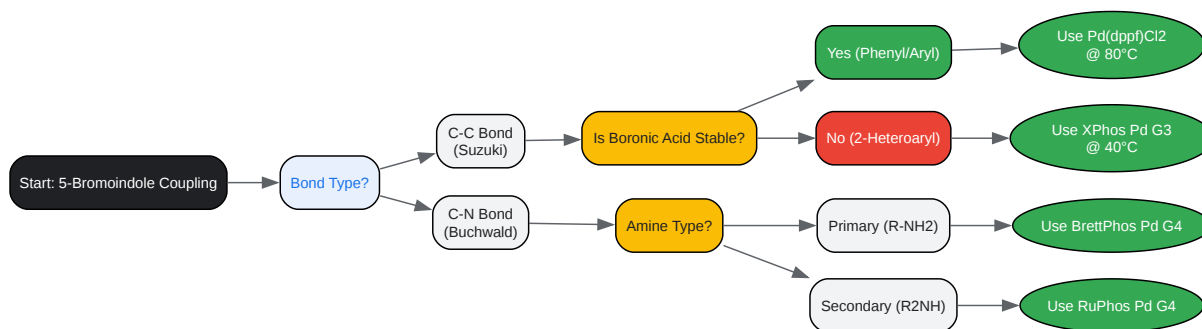

[Click to download full resolution via product page](#)

Caption: Decision matrix for selecting the optimal catalyst based on coupling partner stability and steric requirements.

References

- BenchChem.Application Notes: Palladium-Catalyzed Cross-Coupling of 5-Bromoindoles.[3] (2025).[3][5] [Link](#)
- Sigma-Aldrich.G3 and G4 Buchwald Precatalysts: Representative Coupling Applications and Reaction Scope.[Link](#)
- Organ, M. G., et al.Pd-PEPPSI-IPent: An Active, Sterically Demanding Cross-Coupling Catalyst.[8] *Angew.*[4][8] *Chem. Int. Ed.* (2009).[8] [Link](#)
- CatSci.A General Approach to the Optimisation of Buchwald-Hartwig Aminations.[Link](#)
- Lio, J. et al.The Suzuki Reaction Applied to the Synthesis of Novel Pyrrolyl and Thiophenyl Indazoles. *Molecules* (2012). [Link](#)
- WuXi AppTec.How to Wisely Design Conditions for Buchwald-Hartwig Couplings?[Link](#)

Need Custom Synthesis?

BenchChem offers custom synthesis for rare earth carbides and specific isotopic labeling.

Email: info@benchchem.com or [Request Quote Online](#).

Sources

- [1. youtube.com](https://www.youtube.com) [[youtube.com](https://www.youtube.com)]
- [2. chem.libretexts.org](https://chem.libretexts.org) [chem.libretexts.org]
- [3. pdf.benchchem.com](https://pdf.benchchem.com) [pdf.benchchem.com]
- [4. myers.faculty.chemistry.harvard.edu](https://myers.faculty.chemistry.harvard.edu) [myers.faculty.chemistry.harvard.edu]
- [5. researchgate.net](https://www.researchgate.net) [[researchgate.net](https://www.researchgate.net)]
- [6. The Suzuki Reaction Applied to the Synthesis of Novel Pyrrolyl and Thiophenyl Indazoles - PMC](https://pubmed.ncbi.nlm.nih.gov/115865241/) [[pmc.ncbi.nlm.nih.gov](https://pubmed.ncbi.nlm.nih.gov/115865241/)]
- [7. diva-portal.org](https://diva-portal.org) [diva-portal.org]
- [8. Pd-PEPSSI -IPent catalyst = 95 1158652-41-5](https://www.sigmaaldrich.com) [[sigmaaldrich.com](https://www.sigmaaldrich.com)]
- To cite this document: BenchChem. [Comparative Analysis of Catalysts for 5-Bromoindole Coupling]. BenchChem, [2026]. [Online PDF]. Available at: [<https://www.benchchem.com/product/b1276853/docs#comparative-analysis-of-catalysts-for-5-bromoindole-coupling>]

Disclaimer & Data Validity:

The information provided in this document is for Research Use Only (RUO) and is strictly not intended for diagnostic or therapeutic procedures. While BenchChem strives to provide accurate protocols, we make no warranties, express or implied, regarding the fitness of this product for every specific experimental setup.

Technical Support: The protocols provided are for reference purposes. Unsure if this reagent suits your experiment?

Need Industrial/Bulk Grade? [Request Custom Synthesis Quote](#)

BenchChem

Our mission is to be the trusted global source of essential and advanced chemicals, empowering scientists and researchers to drive progress in science and industry.

Contact

Address: 3281 E Guasti Rd

Ontario, CA 91761, United States

Phone: (601) 213-4426

Email: info@benchchem.com

[Contact our Ph.D. Support Team for a compatibility check](#)