

The Role of 1,4-DPCA in Angiogenesis: A Technical Guide

Author: BenchChem Technical Support Team. **Date:** April 2026

Compound of Interest

Compound Name:	1,4-DPCA
CAS No.:	1382469-40-0
Cat. No.:	B12751491

[Get Quote](#)

For Researchers, Scientists, and Drug Development Professionals

Abstract

1,4-Dihydrophenanthroline-4-one-3-carboxylic acid (**1,4-DPCA**) is a potent small molecule inhibitor of prolyl-4-hydroxylase (PHD) enzymes. Its ability to stabilize the alpha subunit of Hypoxia-Inducible Factor 1 (HIF-1 α) has positioned it as a significant modulator of the angiogenic process. This technical guide provides an in-depth analysis of the molecular mechanisms, experimental evidence, and key signaling pathways associated with **1,4-DPCA**-mediated angiogenesis. It is intended to serve as a comprehensive resource for researchers and professionals in drug development exploring the therapeutic potential of targeting the HIF-1 α pathway for pro- and anti-angiogenic therapies.

Introduction: The Significance of Angiogenesis

Angiogenesis, the formation of new blood vessels from pre-existing ones, is a critical physiological process in development, reproduction, and wound healing. However, it is also a hallmark of various pathological conditions, including tumor growth and metastasis, diabetic retinopathy, and rheumatoid arthritis. The intricate regulation of angiogenesis involves a

delicate balance between pro- and anti-angiogenic factors. A key regulator of this process is the cellular response to hypoxia, primarily mediated by the transcription factor HIF-1.

1,4-DPCA: A Prolyl-4-Hydroxylase Inhibitor

1,4-DPCA is a cell-permeable compound that functions as a potent inhibitor of prolyl-4-hydroxylase (PHD) enzymes.[1] Under normoxic conditions, PHDs hydroxylate specific proline residues on the HIF-1 α subunit, targeting it for ubiquitination and subsequent proteasomal degradation. By inhibiting PHDs, **1,4-DPCA** prevents this degradation, leading to the stabilization and accumulation of HIF-1 α , even in the presence of normal oxygen levels.[2][3] This stabilization allows HIF-1 α to translocate to the nucleus, dimerize with HIF-1 β , and initiate the transcription of a wide array of genes, including those centrally involved in angiogenesis.[2][3]

Mechanism of Action: The HIF-1 α Signaling Pathway

The primary mechanism by which **1,4-DPCA** influences angiogenesis is through the stabilization of HIF-1 α . This initiates a signaling cascade that promotes the expression of several key pro-angiogenic factors.

- **Vascular Endothelial Growth Factor (VEGF):** HIF-1 α is a direct transcriptional activator of the VEGFA gene.[2] VEGF is a potent mitogen and survival factor for endothelial cells, the primary cells lining blood vessels. It promotes endothelial cell proliferation, migration, and tube formation, all essential steps in angiogenesis. Studies have shown that treatment with **1,4-DPCA** leads to an upregulation of VEGF-A production.[2]
- **Chemokine (C-X-C motif) Ligand 12 (CXCL12) and its Receptor (CXCR4):** The HIF-1 α pathway also upregulates the expression of CXCL12 (also known as Stromal cell-Derived Factor-1 or SDF-1) and its receptor, CXCR4.[2] The CXCL12/CXCR4 axis plays a crucial role in cell trafficking and localization to hypoxic microenvironments, including the recruitment of endothelial progenitor cells to sites of neovascularization.[2]
- **Heme Oxygenase 1 (HMOX1):** **1,4-DPCA** treatment has been shown to increase the expression of HMOX1, a pro-angiogenic target gene.[1]

The following diagram illustrates the signaling pathway initiated by **1,4-DPCA**:

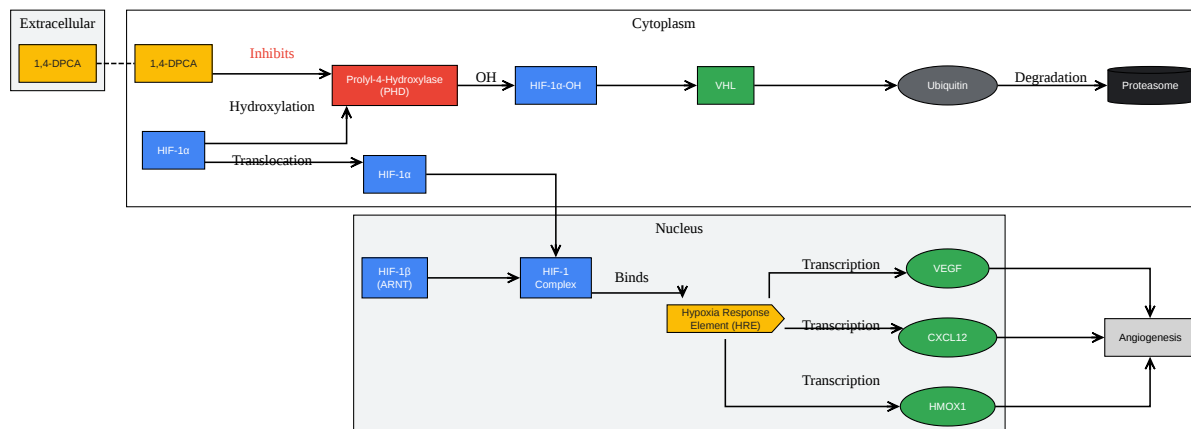

[Click to download full resolution via product page](#)

Caption: 1,4-DPCA inhibits PHD, stabilizing HIF-1α and promoting pro-angiogenic gene expression.

Experimental Evidence and Quantitative Data

The pro-angiogenic effects of **1,4-DPCA** have been demonstrated in various in vitro and in vivo models.

In Vitro Angiogenesis Assays

Standard in vitro assays are employed to assess the direct effects of **1,4-DPCA** on endothelial cells.

- **Tube Formation Assay:** This assay evaluates the ability of endothelial cells to form capillary-like structures on a basement membrane matrix. Treatment with **1,4-DPCA** is expected to enhance tube formation.
- **Cell Migration Assay (Wound Healing/Transwell):** These assays measure the migratory capacity of endothelial cells, a crucial step in angiogenesis. **1,4-DPCA** has been shown to promote cell migration.[2]
- **Cell Proliferation Assay:** The effect of **1,4-DPCA** on endothelial cell proliferation can be quantified using various methods. While some studies show it can inhibit proliferation in certain cancer cell lines, its effect on endothelial cell proliferation in the context of angiogenesis is a key area of investigation.[1]

Table 1: Summary of In Vitro Effects of **1,4-DPCA** on Angiogenesis

Assay	Cell Type	1,4-DPCA Concentration	Observed Effect	Reference
Gene Expression	Mouse B6 cells	Not specified	Increased expression of Vegfa and Hmox1	[1]
Gene Expression	Human Gingival Epithelial & PDL cells	Not specified	Enhanced production of VEGF-A and CXCL12	[2]
Cell Proliferation	T4-2, ZR-75-1, MDA-MB-157, MDA-MB-231	10-20 μ M	Inhibition of proliferation	[1]

In Vivo Angiogenesis Models

Animal models provide a more complex physiological system to study the effects of **1,4-DPCA** on angiogenesis.

- Mouse Model of Periodontitis:** In a mouse model of ligature-induced periodontitis, subcutaneous injection of a **1,4-DPCA** hydrogel increased the numbers of CD31+CD45- endothelial cells in the gingival tissue, indicating enhanced angiogenesis.[2] This was associated with tissue regeneration.[2][4][5]
- Mouse Ear Punch Injury Model:** Systemic delivery of **1,4-DPCA** in a hydrogel carrier promoted tissue regeneration in an ear hole punch injury model in mice, a response that was dependent on HIF-1 α . [2] This regenerative response is often associated with increased vascularization.[3]

Table 2: Summary of In Vivo Effects of **1,4-DPCA** on Angiogenesis

Animal Model	Administration Route	1,4-DPCA Formulation	Observed Angiogenic Effect	Reference
Ligature-Induced Periodontitis (Mouse)	Subcutaneous Injection	Hydrogel	Increased numbers of CD31+CD45- endothelial cells	[2]
Ear Punch Injury (Mouse)	Systemic Delivery	Hydrogel	Promoted tissue regeneration (HIF-1 α -dependent)	[2]
Periodontal Disease (Mouse)	Systemic Administration	PEG gel	Increased vascularization in the tooth pulp	[3][6]

Experimental Protocols

Detailed methodologies are crucial for the reproducibility of scientific findings. Below are representative protocols for key experiments.

Western Blot for HIF-1 α Stabilization

This protocol is designed to detect the stabilization of HIF-1 α in cell lysates following treatment with **1,4-DPCA**.



[Click to download full resolution via product page](#)

Caption: Workflow for detecting HIF-1 α stabilization by Western blot after **1,4-DPCA** treatment.

Protocol Details:

- **Cell Culture and Treatment:** Plate endothelial cells (e.g., HUVECs) and grow to 70-80% confluency. Treat cells with desired concentrations of **1,4-DPCA** for a specified time (e.g., 4-24 hours). Include a vehicle control (e.g., DMSO).
- **Cell Lysis:** Wash cells with ice-cold PBS and lyse using a suitable buffer (e.g., RIPA buffer) supplemented with protease and phosphatase inhibitors. Scrape cells and collect the lysate.
- **Protein Quantification:** Determine the protein concentration of each lysate using a BCA or Bradford assay.
- **SDS-PAGE and Transfer:** Load equal amounts of protein (e.g., 20-40 μ g) onto an SDS-polyacrylamide gel. After electrophoresis, transfer the proteins to a PVDF membrane.
- **Immunoblotting:** Block the membrane with 5% non-fat dry milk in TBST for 1 hour. Incubate with a primary antibody against HIF-1 α overnight at 4°C. Wash the membrane and incubate with an HRP-conjugated secondary antibody for 1 hour at room temperature.
- **Detection:** Visualize the protein bands using an enhanced chemiluminescence (ECL) detection system.

In Vitro Tube Formation Assay

This protocol outlines the steps to assess the effect of **1,4-DPCA** on the formation of capillary-like structures by endothelial cells.

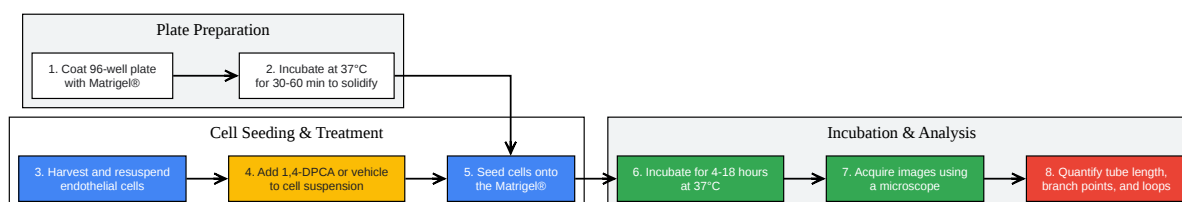

[Click to download full resolution via product page](#)

Caption: Workflow for the in vitro tube formation assay to assess angiogenesis.

Protocol Details:

- **Plate Coating:** Thaw Matrigel® or a similar basement membrane matrix on ice. Coat the wells of a 96-well plate with the Matrigel® and incubate at 37°C for 30-60 minutes to allow for solidification.
- **Cell Preparation and Seeding:** Harvest endothelial cells (e.g., HUVECs) and resuspend them in a serum-reduced medium. Add **1,4-DPCA** at various concentrations to the cell suspension. Seed the cells onto the solidified Matrigel®.
- **Incubation and Imaging:** Incubate the plate at 37°C for 4-18 hours. Monitor the formation of tube-like structures at regular intervals. Capture images using a phase-contrast microscope.
- **Quantification:** Analyze the images using software (e.g., ImageJ with an angiogenesis plugin) to quantify parameters such as total tube length, number of branch points, and number of loops.

Therapeutic Implications and Future Directions

The ability of **1,4-DPCA** to promote angiogenesis through HIF-1 α stabilization holds significant therapeutic potential, particularly in the field of regenerative medicine. By enhancing blood vessel formation, **1,4-DPCA** could be beneficial in treating conditions characterized by ischemia or poor vascularization, such as chronic wounds, peripheral artery disease, and in promoting tissue regeneration after injury.^{[2][3][4][5]}

Conversely, the central role of angiogenesis in tumor growth suggests that targeting the HIF-1 α pathway could also be a viable anti-cancer strategy. While **1,4-DPCA** itself promotes angiogenesis, understanding its mechanism provides a blueprint for developing inhibitors of this pathway to restrict tumor blood supply.

Future research should focus on:

- **Dose-Response and Toxicity Profiles:** Establishing optimal therapeutic windows for **1,4-DPCA** to maximize pro-angiogenic effects while minimizing potential off-target effects.
- **Delivery Systems:** Developing targeted delivery systems, such as hydrogels, to localize the action of **1,4-DPCA** to specific tissues and reduce systemic exposure.^{[2][7]}
- **Combination Therapies:** Investigating the synergistic effects of **1,4-DPCA** with other growth factors or therapeutic agents to enhance tissue regeneration.
- **Clinical Trials:** As of now, there is a lack of information on clinical trials specifically for **1,4-DPCA** in the context of angiogenesis. This represents a critical next step in translating the promising preclinical findings into clinical applications.

Conclusion

1,4-DPCA is a powerful tool for modulating angiogenesis through the stabilization of HIF-1 α . Its well-defined mechanism of action and demonstrated efficacy in preclinical models make it a compound of high interest for both basic research and therapeutic development. This technical guide provides a foundational understanding of **1,4-DPCA**'s role in angiogenesis, offering valuable insights for scientists and researchers working to harness the therapeutic potential of the HIF-1 α pathway. The continued exploration of **1,4-DPCA** and similar molecules will

undoubtedly pave the way for novel treatments for a wide range of angiogenesis-dependent diseases.

Need Custom Synthesis?

BenchChem offers custom synthesis for rare earth carbides and specific isotopic labeling.

Email: info@benchchem.com or [Request Quote Online](#).

References

- [1. medchemexpress.com \[medchemexpress.com\]](https://www.medchemexpress.com)
- [2. An injectable hydrogel-formulated inhibitor of prolyl-4-hydroxylase promotes T regulatory cell recruitment and enhances alveolar bone regeneration during resolution of experimental periodontitis - PMC \[pmc.ncbi.nlm.nih.gov\]](#)
- [3. Prolyl-hydroxylase inhibitor-induced regeneration of alveolar bone and soft tissue in a mouse model of periodontitis through metabolic reprogramming - PMC \[pmc.ncbi.nlm.nih.gov\]](#)
- [4. Prolyl-hydroxylase inhibitor-induced regeneration of alveolar bone and soft tissue in a mouse model of periodontitis through metabolic reprogramming - PubMed \[pubmed.ncbi.nlm.nih.gov\]](#)
- [5. An injectable hydrogel-formulated inhibitor of prolyl-4-hydroxylase promotes T regulatory cell recruitment and enhances alveolar bone regeneration during resolution of experimental periodontitis - PubMed \[pubmed.ncbi.nlm.nih.gov\]](#)
- [6. Frontiers | Prolyl-hydroxylase inhibitor-induced regeneration of alveolar bone and soft tissue in a mouse model of periodontitis through metabolic reprogramming \[frontiersin.org\]](#)
- [7. researchgate.net \[researchgate.net\]](https://www.researchgate.net)
- To cite this document: BenchChem. [The Role of 1,4-DPCA in Angiogenesis: A Technical Guide]. BenchChem, [2026]. [Online PDF]. Available at: [\[https://www.benchchem.com/product/b12751491/docs#the-role-of-1-4-dpca-in-angiogenesis-a-technical-guide\]](https://www.benchchem.com/product/b12751491/docs#the-role-of-1-4-dpca-in-angiogenesis-a-technical-guide)

Disclaimer & Data Validity:

The information provided in this document is for Research Use Only (RUO) and is strictly not intended for diagnostic or therapeutic procedures. While BenchChem strives to provide accurate protocols, we make no warranties, express or implied, regarding the fitness of this product for every specific experimental setup.

Technical Support: The protocols provided are for reference purposes. Unsure if this reagent suits your experiment?

Need Industrial/Bulk Grade? [Request Custom Synthesis Quote](#)

BenchChem

Our mission is to be the trusted global source of essential and advanced chemicals, empowering scientists and researchers to drive progress in science and industry.

Contact

Address: 3281 E Guasti Rd
Ontario, CA 91761, United States
Phone: (601) 213-4426
Email: info@benchchem.com

[Contact our Ph.D. Support Team for a compatibility check](#)