

Technical Support Center: Optimizing Phenoxyalkanoic Acid Synthesis

Author: BenchChem Technical Support Team. **Date:** May 2026

Compound of Interest

Compound Name: 2-(3-Methylphenoxy)butanoic acid

CAS No.: 113104-27-1

Cat. No.: B1275976

[Get Quote](#)

Welcome to the technical support center for phenoxyalkanoic acid synthesis. This guide is designed for researchers, scientists, and drug development professionals to navigate the complexities of this synthetic process and effectively minimize byproduct formation. Drawing upon established chemical principles and field-proven insights, this resource provides in-depth troubleshooting guides, frequently asked questions, and validated protocols to enhance the yield and purity of your target compounds.

Section 1: Troubleshooting Guide - Navigating Common Synthesis Challenges

This section addresses specific issues that may arise during the synthesis of phenoxyalkanoic acids, providing causal explanations and actionable solutions.

Q1: I am observing a significant amount of hydroxyalkanoic acid in my reaction mixture. What is the cause and how can I prevent it?

A1: The presence of hydroxyalkanoic acid is a common issue, primarily arising from the hydrolysis of the haloalkanoic acid reactant.[1][2] This side reaction is competitive with the desired Williamson ether synthesis.

Causality: The formation of hydroxyalkanoic acid is favored by the presence of water and hydroxide ions in the reaction mixture. The hydroxide ions, intended to deprotonate the phenol, can also act as nucleophiles and attack the haloalkanoic acid.

Troubleshooting Protocol:

- **Minimize Water Content:** Ensure all reactants and solvents are as dry as possible. Water is often introduced as a solvent or is a byproduct of the initial acid-base reaction between the phenol and the alkali metal hydroxide.[1] Consider using a two-phase water-organic reaction medium or techniques that remove water as it is formed, such as azeotropic distillation.[1]
- **Control Stoichiometry and Addition Rate:** The simultaneous addition of equivalent amounts of the haloalkanoic acid and the alkali metal hydroxide to a hot mixture of the phenol and its alkali metal salt can minimize the concentration of free hydroxide ions available for the hydrolysis side reaction.[1]
- **Optimize pH:** Maintain the reaction pH in a range that favors the phenoxide as the dominant nucleophile without having an excessive concentration of hydroxide ions. A weakly basic medium, using carbonates instead of hydroxides, can sometimes be advantageous.[3]
- **Temperature Control:** While higher temperatures can increase the rate of the desired reaction, they can also accelerate the hydrolysis of the haloalkanoic acid.[4][5] The optimal temperature should be determined empirically for your specific system.

Q2: My final product is contaminated with unreacted phenol. How can I improve the conversion of my starting material?

A2: Incomplete conversion of the starting phenol is a frequent challenge that directly impacts yield and purity. This can be due to several factors, including insufficient reactivity of the electrophile, steric hindrance, or suboptimal reaction conditions.

Causality: The Williamson ether synthesis is an SN2 reaction, and its efficiency is highly dependent on the nature of the reactants and the reaction environment.[6][7] If the phenoxide nucleophile cannot efficiently attack the haloalkanoic acid, the starting phenol will remain.

Troubleshooting Protocol:

- **Choice of Haloalkanoic Acid:** The reactivity of the haloalkanoic acid is critical. The leaving group ability follows the trend $I > Br > Cl$. [8][9] While chloroacetic acid is commonly used, switching to bromoacetic or iodoacetic acid can significantly enhance the reaction rate. However, this must be balanced with cost and availability.
- **Base Selection:** Ensure complete deprotonation of the phenol to form the more nucleophilic phenoxide. A strong base like sodium hydride (NaH) or potassium hydride (KH) can be more effective than alkali metal hydroxides, particularly for less acidic phenols. [6]
- **Solvent Effects:** The choice of solvent can dramatically influence the reaction rate. Polar aprotic solvents like DMF (dimethylformamide) or DMSO (dimethyl sulfoxide) are often preferred as they solvate the cation of the alkoxide, leaving the anionic nucleophile more reactive. [10]
- **Increase Reaction Time and/or Temperature:** If the reaction is sluggish, extending the reaction time or cautiously increasing the temperature can drive it to completion. [11] Monitor the reaction progress by a suitable analytical technique (e.g., TLC, HPLC) to determine the optimal endpoint and avoid decomposition.

Q3: I am observing the formation of an unexpected byproduct that I suspect is a result of C-alkylation. Is this possible and how can I avoid it?

A3: While O-alkylation is the desired pathway in the Williamson ether synthesis, competitive C-alkylation of the phenoxide can occur, particularly with phenols that have electron-rich aromatic rings.

Causality: The phenoxide ion is an ambident nucleophile, meaning it can react at either the oxygen or the carbon atoms of the aromatic ring. The regioselectivity of the alkylation is influenced by factors such as the solvent, counter-ion, and the nature of the electrophile.

Troubleshooting Protocol:

- **Solvent Choice:** Polar protic solvents can favor O-alkylation by solvating the phenoxide oxygen, making it less available for reaction and promoting reaction at the less-solvated carbon positions. Conversely, polar aprotic solvents generally favor O-alkylation.
- **Counter-ion Effect:** The nature of the cation associated with the phenoxide can influence the O/C alkylation ratio. Larger, softer cations tend to favor O-alkylation.
- **Reaction Temperature:** Lower reaction temperatures generally favor O-alkylation, as the transition state for this pathway is typically lower in energy.

Section 2: Frequently Asked Questions (FAQs)

A quick reference for common queries regarding phenoxyalkanoic acid synthesis.

- **What are the most common byproducts in phenoxyalkanoic acid synthesis?** The most prevalent byproduct is the corresponding hydroxyalkanoic acid, formed from the hydrolysis of the haloalkanoic acid starting material.^[1] Unreacted starting phenol is also a common impurity. Depending on the specific substrates and conditions, byproducts from C-alkylation or self-condensation of reactants can also be observed.^[10]
- **How can I purify my crude phenoxyalkanoic acid product?** Purification is typically achieved through a combination of techniques. An initial workup involving acidification of the reaction mixture to precipitate the carboxylic acid, followed by extraction into an organic solvent, is common.^[10] Further purification can be achieved by recrystallization from a suitable solvent or by column chromatography.^[11]
- **What analytical techniques are suitable for monitoring the reaction and assessing product purity?** Thin-layer chromatography (TLC) is a rapid and effective technique for monitoring the progress of the reaction. For quantitative analysis and purity assessment, High-Performance Liquid Chromatography (HPLC) and Gas Chromatography (GC) are widely used.^{[12][13]} For GC analysis, derivatization of the carboxylic acid to its methyl ester is often necessary.^[12]
- **What is the optimal pH for the reaction?** The optimal pH is a balance between ensuring the phenol is deprotonated to its more reactive phenoxide form and minimizing the concentration of hydroxide ions that can lead to the hydrolysis of the haloalkanoic acid.^[1] This typically

translates to alkaline conditions, but the exact pH should be optimized for each specific reaction.

Section 3: Experimental Protocols

The following are generalized protocols that should be adapted and optimized for specific substrates and scales.

Protocol 1: Synthesis of a Generic Phenoxyalkanoic Acid

- **Reactant Preparation:** In a round-bottom flask equipped with a magnetic stirrer and a reflux condenser, dissolve the substituted phenol in a suitable solvent (e.g., ethanol, DMF).
- **Base Addition:** Add a stoichiometric equivalent of a base (e.g., sodium hydroxide, potassium carbonate) to the solution and stir until the phenol is completely converted to its corresponding phenoxide salt.
- **Addition of Haloalkanoic Acid:** Slowly add a slight excess (e.g., 1.1 equivalents) of the haloalkanoic acid to the reaction mixture.
- **Reaction:** Heat the mixture to reflux and monitor the reaction progress using TLC or HPLC. The reaction time will vary depending on the reactivity of the substrates.
- **Workup:** After the reaction is complete, cool the mixture to room temperature and remove the solvent under reduced pressure. Dissolve the residue in water and acidify with a mineral acid (e.g., HCl) to a pH of approximately 2 to precipitate the crude phenoxyalkanoic acid.
- **Isolation:** Collect the precipitate by vacuum filtration and wash with cold water to remove inorganic salts.
- **Purification:** Recrystallize the crude product from an appropriate solvent system to obtain the pure phenoxyalkanoic acid.

Protocol 2: Purification by Recrystallization

- **Solvent Selection:** Choose a solvent in which the phenoxyalkanoic acid is sparingly soluble at room temperature but highly soluble at elevated temperatures.
- **Dissolution:** Dissolve the crude product in the minimum amount of the hot solvent.
- **Decolorization (Optional):** If the solution is colored, add a small amount of activated charcoal and heat for a short period.
- **Hot Filtration:** Quickly filter the hot solution through a pre-warmed funnel to remove any insoluble impurities and the activated charcoal.
- **Crystallization:** Allow the filtrate to cool slowly to room temperature, and then in an ice bath, to induce crystallization.
- **Isolation and Drying:** Collect the crystals by vacuum filtration, wash with a small amount of the cold solvent, and dry under vacuum.

Section 4: Data Presentation and Visualization

Table 1: Impact of Reaction Parameters on Byproduct Formation

Parameter	Condition	Impact on Hydroxyalkanoic Acid Formation	Impact on Unreacted Phenol	Recommended Action
Water Content	High	Increased	No direct impact	Use dry solvents and reactants.
Base	Strong (e.g., NaOH)	Increased	Decreased	Use a weaker base (e.g., K ₂ CO ₃) or control addition rate.
Temperature	High	Increased	Decreased	Optimize for a balance between reaction rate and byproduct formation.
Leaving Group	Poor (e.g., -Cl)	No direct impact	Increased	Use a better leaving group (e.g., -Br, -I) if feasible.

Diagrams

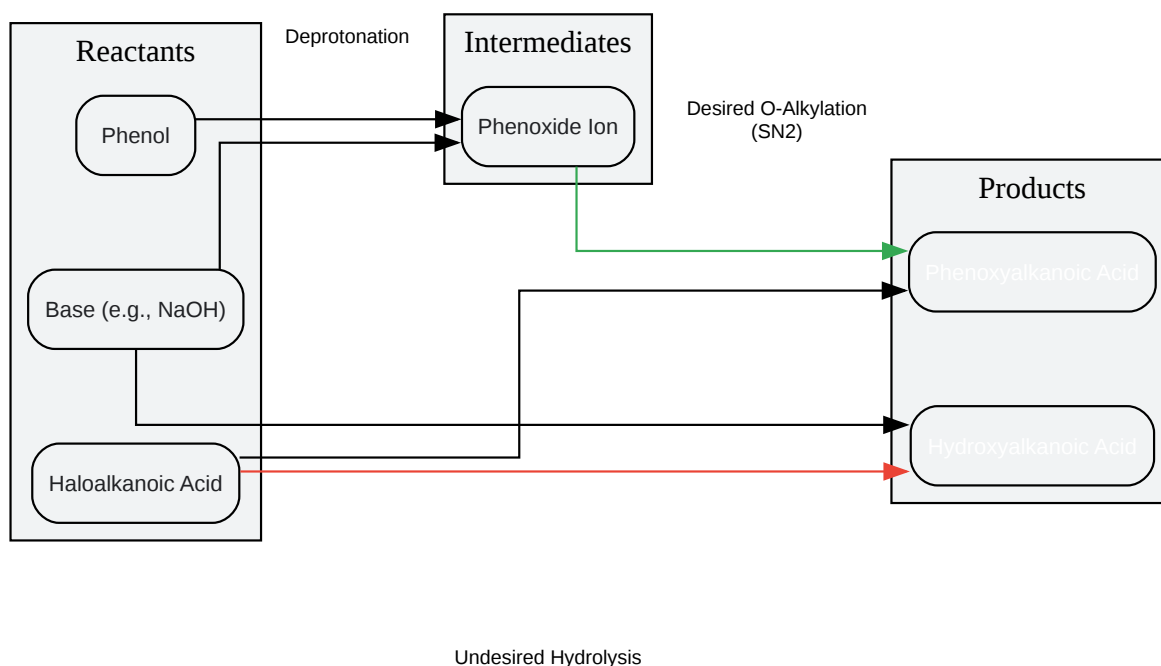

[Click to download full resolution via product page](#)

Caption: Reaction scheme for phenoxyalkanoic acid synthesis highlighting the desired and undesired pathways.

Caption: A troubleshooting workflow for addressing common byproduct issues in phenoxyalkanoic acid synthesis.

References

- EP0334595A2 - Synthesis of 2-(4-hydroxyphenoxy)alkanoic acids - Google Patents.
- Method 1658: The Determination of Phenoxy-Acid Herbicides in Municipal and Industrial Wastewater - EPA. Available at: [\[Link\]](#)
- US4035416A - Process for making phenoxyalkanoic acids - Google Patents.
- BIOLOGICAL DEGRADATION OF THE PHENOXY ACID HERBICIDE 2,4-DICHLOROPHENOXYACETIC ACID (2,4-D) Submitted to the Faculty of Gricidua - Bibliothèque et Archives Canada. Available at: [\[Link\]](#)

- The Production of Phenoxy Herbicides. Available at: [\[Link\]](#)
- Leaving Groups - Chemistry LibreTexts. Available at: [\[Link\]](#)
- The Williamson Ether Synthesis - Master Organic Chemistry. Available at: [\[Link\]](#)
- CN109776301B - Synthesis method of 2, 4-dichlorophenoxyacetic acid compound - Google Patents.
- How does reaction time impact synthetic product purity and yield? - Biotage. Available at: [\[Link\]](#)
- Determination and Occurrence of Phenoxyacetic Acid Herbicides and Their Transformation Products in Groundwater Using Ultra High Performance Liquid Chromatography Coupled to Tandem Mass Spectrometry - NIH. Available at: [\[Link\]](#)
- Byproduct formation during the biosynthesis of spinosyn A and evidence for an enzymatic interplay to prevent its formation - NIH. Available at: [\[Link\]](#)
- Preparation method of phenoxy-carboxylic acid herbicides - Google Patents.
- Degradation of phenoxyalkanoic acid herbicides by isolated bacterial strain LKDC4 *Pseudomonas aeruginosa* - PubMed. Available at: [\[Link\]](#)
- The Conjugate Acid Is A Better Leaving Group - Master Organic Chemistry. Available at: [\[Link\]](#)
- (PDF) Process design for the production of 2,4-dichlorophenoxyacetic acid - ResearchGate. Available at: [\[Link\]](#)
- Maximizing Yield and Purity: Strategies for Fine Chemical Synthesis - AZoM. Available at: [\[Link\]](#)
- 2,4-DICHLOROPHENOXYACETIC ACID - IARC Publications. Available at: [\[Link\]](#)
- Phenoxy Herbicides: Production, Uses And Toxicology - Chemcess. Available at: [\[Link\]](#)

- Biological Profile and Synthesis of Phenoxyacetic Acid Derivatives: A Review - Jetir.Org. Available at: [\[Link\]](#)
- Williamson Ether Synthesis - Chemistry LibreTexts. Available at: [\[Link\]](#)
- Small Molecule Development Analytical Methods for Faster Time to Market - Hovione. Available at: [\[Link\]](#)
- Recent advances in heterolytic nucleofugal leaving groups - PMC - NIH. Available at: [\[Link\]](#)
- (PDF) Microwave-Assisted Synthesis of 2-Phenoxybenzoic Acids - ResearchGate. Available at: [\[Link\]](#)
- Effect of Temperature on the Purity and Yield of Aspirin - AWS. Available at: [\[Link\]](#)
- Novel phenoxyacetic herbicides synthesized from longifolene-derived primary amine for sustainable weed management - PMC - NIH. Available at: [\[Link\]](#)
- Mechanism of Formation of the crazy Byproducts in Sharpless Dihydroxylation Reaction. Available at: [\[Link\]](#)
- Can Reaction Temperature Impact Synthetic Product Yield and Purity? - Biotage. Available at: [\[Link\]](#)
- Design, Synthesis, and Biological Evaluation of Novel Phenoxy Acetic Acid Derivatives as Selective COX-2 Inhibitors Coupled with Comprehensive Bio-Pharmacological Inquiry, Histopathological Profiling, and Toxicological Scrutiny - PMC - PubMed Central. Available at: [\[Link\]](#)
- Williamson Ether Synthesis reaction - BYJU'S. Available at: [\[Link\]](#)
- Leaving group - Wikipedia. Available at: [\[Link\]](#)
- 2,4-Dichlorophenoxyacetic acid - Wikipedia. Available at: [\[Link\]](#)
- A facile synthesis of 2-(4-((4-chlorophenyl)(hydroxy)methyl) phenoxy)-2-methylpropanoic acid: Metabolite of anti-hyperlipidemic drug Fenofibrate - PMC - NIH. Available at: [\[Link\]](#)

- Phenoxy-carboxylic acid herbicides in environment: Recent updates on pretreatment and analysis methods - PubMed. Available at: [\[Link\]](#)
- DEVELOPMENT OF A SYNTHETIC ROUTE TO THE ACTIVE INGREDIENT OF AN AGRICULTURAL HERBICIDE by Rory O'Donovan A Thesis submitted fo. Available at: [\[Link\]](#)
- Williamson ether synthesis | Organic Chemistry 1: An open textbook - Lumen Learning. Available at: [\[Link\]](#)
- Development of an Extraction Method Based on a Zirconium-based Metal Organic Framework for the Detection and Determination of some Pesticid - Regular Article. Available at: [\[Link\]](#)
- Common Leaving Groups. Available at: [\[Link\]](#)
- Synthesis of 2,4-D ester herbicides . New routes using inorganic solid supports. Available at: [\[Link\]](#)
- Design, Synthesis, and Biological Evaluation of Novel Phenoxy Acetic Acid Derivatives as Selective COX-2 Inhibitors Coupled with Comprehensive Bio-Pharmacological Inquiry, Histopathological Profiling, and Toxicological Scrutiny - MDPI. Available at: [\[Link\]](#)
- Williamson Ether Synthesis: O-Alkylation Reaction Using Halogenated Hydrocarbons as Alkylating Agents | Francis Academic Press. Available at: [\[Link\]](#)
- Analytical Methods - OPUS. Available at: [\[Link\]](#)
- Determination of Phenoxy Acid Herbicides From Aqueous Samples by Improved Clean-up on Polymeric Pre-columns at High pH - Analyst (RSC Publishing). Available at: [\[Link\]](#)

Need Custom Synthesis?

BenchChem offers custom synthesis for rare earth carbides and specific isotopic labeling.

Email: info@benchchem.com or [Request Quote Online](#).

Sources

- [1. US4035416A - Process for making phenoxyalkanoic acids - Google Patents \[patents.google.com\]](#)
- [2. nzic.org.nz \[nzic.org.nz\]](#)
- [3. CN109776301B - Synthesis method of 2, 4-dichlorophenoxyacetic acid compound - Google Patents \[patents.google.com\]](#)
- [4. terra-docs.s3.us-east-2.amazonaws.com \[terra-docs.s3.us-east-2.amazonaws.com\]](#)
- [5. biotage.com \[biotage.com\]](#)
- [6. masterorganicchemistry.com \[masterorganicchemistry.com\]](#)
- [7. byjus.com \[byjus.com\]](#)
- [8. chem.libretexts.org \[chem.libretexts.org\]](#)
- [9. Recent advances in heterolytic nucleofugal leaving groups - PMC \[pmc.ncbi.nlm.nih.gov\]](#)
- [10. EP0334595A2 - Synthesis of 2-\(4-hydroxyphenoxy\)alkanoic acids - Google Patents \[patents.google.com\]](#)
- [11. biotage.com \[biotage.com\]](#)
- [12. epa.gov \[epa.gov\]](#)
- [13. Determination and Occurrence of Phenoxyacetic Acid Herbicides and Their Transformation Products in Groundwater Using Ultra High Performance Liquid Chromatography Coupled to Tandem Mass Spectrometry - PMC \[pmc.ncbi.nlm.nih.gov\]](#)
- To cite this document: BenchChem. [Technical Support Center: Optimizing Phenoxyalkanoic Acid Synthesis]. BenchChem, [2026]. [Online PDF]. Available at: [\[https://www.benchchem.com/product/b1275976/docs#technical-support-center-optimizing-phenoxyalkanoic-acid-synthesis\]](https://www.benchchem.com/product/b1275976/docs#technical-support-center-optimizing-phenoxyalkanoic-acid-synthesis)

Disclaimer & Data Validity:

The information provided in this document is for Research Use Only (RUO) and is strictly not intended for diagnostic or therapeutic procedures. While BenchChem strives to provide accurate protocols, we make no warranties, express or implied, regarding the fitness of this product for every specific experimental setup.

Technical Support: The protocols provided are for reference purposes. Unsure if this reagent suits your experiment?

Need Industrial/Bulk Grade? [Request Custom Synthesis Quote](#)

BenchChem

Our mission is to be the trusted global source of essential and advanced chemicals, empowering scientists and researchers to drive progress in science and industry.

Contact

Address: 3281 E Guasti Rd
Ontario, CA 91761, United States
Phone: (601) 213-4426
Email: info@benchchem.com

[Contact our Ph.D. Support Team for a compatibility check](#)