

Application Notes and Protocols: The Sulfoxide-Magnesium Exchange in Modern Synthesis

Author: BenchChem Technical Support Team. **Date:** May 2026

Compound of Interest

Compound Name: *1-Bromo-4-(methylsulfinyl)benzene*
CAS No.: 934-71-4
Cat. No.: B1274105

[Get Quote](#)

Introduction: Beyond a Protecting Group - The Sulfoxide as a Linchpin in C-C Bond Formation

For decades, the sulfoxide group has been a cornerstone in organic synthesis, primarily recognized for its role as a potent chiral auxiliary and a directing group in electrophilic aromatic substitution.[1][2] However, its reactivity landscape is far broader and more nuanced. A particularly powerful, yet sometimes overlooked, transformation is the sulfoxide-magnesium exchange reaction. This process allows for the direct conversion of an aryl sulfoxide into a highly functionalized Grignard reagent, unlocking a gateway to a diverse array of complex molecules.[3][4]

This technical guide delves into the reaction of **1-Bromo-4-(methylsulfinyl)benzene** with Grignard reagents, a process that elegantly combines a halogen-magnesium exchange with a subsequent sulfoxide-magnesium exchange. We will explore the underlying mechanisms, provide a detailed experimental protocol, and showcase its applications in the synthesis of valuable biaryl compounds, a motif prevalent in pharmaceuticals and advanced materials.[5]

This document is intended for researchers, scientists, and drug development professionals seeking to leverage this versatile methodology in their synthetic endeavors.

Theoretical Background: The Mechanism of the Sulfoxide-Magnesium Exchange

The reaction of an aryl sulfoxide with a Grignard reagent initiates a fascinating cascade of events. The process, known as a sulfoxide-magnesium exchange, involves the displacement of the sulfinyl group by the alkyl or aryl group of the Grignard reagent, ultimately forming a new organomagnesium species.^{[3][6][7]}

The currently accepted mechanism proceeds through the formation of a transient sulfurane intermediate. The Grignard reagent, acting as a nucleophile, attacks the electrophilic sulfur atom of the sulfoxide. This leads to a hypervalent sulfur species which then undergoes ligand coupling and reductive elimination to furnish the new Grignard reagent and a sulfenate byproduct.^[1]

In the specific case of **1-Bromo-4-(methylsulfinyl)benzene**, the reaction with a Grignard reagent like isopropylmagnesium chloride (often used as a "turbo Grignard" reagent in the form of $i\text{PrMgCl}\cdot\text{LiCl}$ for enhanced reactivity) can proceed via two main pathways:

- **Halogen-Magnesium Exchange:** The Grignard reagent can first undergo a bromine-magnesium exchange with the aryl bromide, generating 4-(methylsulfinyl)phenylmagnesium bromide.
- **Sulfoxide-Magnesium Exchange:** Subsequently, or concurrently, another equivalent of the Grignard reagent can react with the sulfoxide moiety, leading to the formation of a di-Grignard reagent or undergoing further reactions.

The precise outcome can be controlled by stoichiometry and reaction conditions. For the purpose of this guide, we will focus on a scenario where the sulfoxide group is ultimately displaced to facilitate a cross-coupling reaction.

Experimental Protocol: Synthesis of a Biaryl Compound via a Tandem Halogen-Magnesium

Exchange and Kumada Coupling

This protocol outlines a representative procedure for the synthesis of a 4-substituted biphenyl derivative, leveraging the in-situ generated Grignard reagent from **1-Bromo-4-(methylsulfinyl)benzene** in a subsequent nickel-catalyzed Kumada coupling reaction.^{[8][9][10]}

Materials:

- **1-Bromo-4-(methylsulfinyl)benzene**
- Magnesium turnings
- Isopropylmagnesium chloride lithium chloride complex (iPrMgCl·LiCl, "Turbo Grignard") solution in THF (commercially available or prepared)^[11]
- Anhydrous Tetrahydrofuran (THF)
- Aryl bromide (coupling partner)
- [1,3-Bis(diphenylphosphino)propane]nickel(II) chloride (NiCl₂(dppp))
- Anhydrous diethyl ether
- Saturated aqueous ammonium chloride (NH₄Cl) solution
- Saturated aqueous sodium bicarbonate (NaHCO₃) solution
- Brine (saturated aqueous NaCl solution)
- Anhydrous magnesium sulfate (MgSO₄) or sodium sulfate (Na₂SO₄)
- Silica gel for column chromatography
- Solvents for chromatography (e.g., hexanes, ethyl acetate)

Equipment:

- Three-neck round-bottom flask

- Reflux condenser
- Dropping funnel
- Magnetic stirrer and stir bar
- Inert gas (Argon or Nitrogen) supply with manifold
- Schlenk line or glovebox for handling air- and moisture-sensitive reagents
- Heating mantle or oil bath
- Ice bath
- Standard laboratory glassware for workup and purification
- Rotary evaporator

Workflow Diagram:

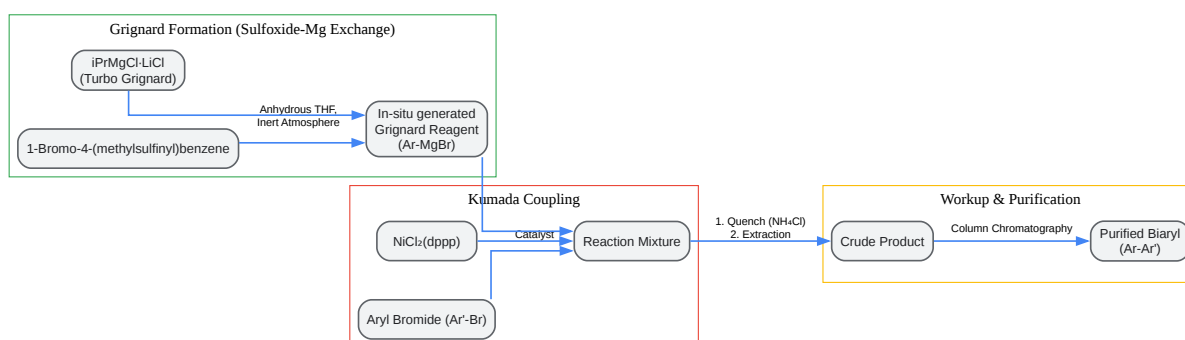

[Click to download full resolution via product page](#)

Need Custom Synthesis?

BenchChem offers custom synthesis for rare earth carbides and specific isotopic labeling.

Email: info@benchchem.com or [Request Quote Online](#).

Sources

- [1. pubs.acs.org](https://pubs.acs.org) [pubs.acs.org]
- [2. researchgate.net](https://researchgate.net) [researchgate.net]
- [3. chemrxiv.org](https://chemrxiv.org) [chemrxiv.org]
- [4. Thieme E-Journals - Synfacts / Abstract](https://thieme-connect.com) [thieme-connect.com]
- [5. chemrevlett.com](https://chemrevlett.com) [chemrevlett.com]
- [6. A Sulfoxide Reagent for One-Pot, Three-Component Syntheses of Sulfoxides and Sulfinamides - PMC](https://pubmed.ncbi.nlm.nih.gov) [[pmc.ncbi.nlm.nih.gov](https://pubmed.ncbi.nlm.nih.gov)]
- [7. Reaction of sulfoxides with grignard reagents | Semantic Scholar](https://www.semanticscholar.org) [[semanticscholar.org](https://www.semanticscholar.org)]
- [8. researchgate.net](https://researchgate.net) [researchgate.net]
- [9. Kumada coupling - Wikipedia](https://en.wikipedia.org) [en.wikipedia.org]
- [10. Kumada Coupling](https://www.organic-chemistry.org) [[organic-chemistry.org](https://www.organic-chemistry.org)]
- [11. researchgate.net](https://researchgate.net) [researchgate.net]
- To cite this document: BenchChem. [Application Notes and Protocols: The Sulfoxide-Magnesium Exchange in Modern Synthesis]. BenchChem, [2026]. [Online PDF]. Available at: [<https://www.benchchem.com/product/b1274105/docs#application-notes-and-protocols-the-sulfoxide-magnesium-exchange-in-modern-synthesis>]

Disclaimer & Data Validity:

The information provided in this document is for Research Use Only (RUO) and is strictly not intended for diagnostic or therapeutic procedures. While BenchChem strives to provide accurate protocols, we make no warranties, express or implied, regarding the fitness of this product for every specific experimental setup.

Technical Support: The protocols provided are for reference purposes. Unsure if this reagent suits your experiment?

Need Industrial/Bulk Grade? [Request Custom Synthesis Quote](#)

BenchChem

Our mission is to be the trusted global source of essential and advanced chemicals, empowering scientists and researchers to drive progress in science and industry.

Contact

Address: 3281 E Guasti Rd
Ontario, CA 91761, United States
Phone: (601) 213-4426
Email: info@benchchem.com

[Contact our Ph.D. Support Team for a compatibility check](#)