

Application Note: Selective Synthesis of N-(But-2-ynyl)-4-methylaniline

Author: BenchChem Technical Support Team. **Date:** May 2026

Compound of Interest

Compound Name: *But-2-ynyl-p-tolyl-amine*

CAS No.: 435345-29-2

Cat. No.: B1274550

[Get Quote](#)

Introduction & Strategic Significance

N-(But-2-ynyl)-4-methylaniline (also referred to as N-(but-2-ynyl)-p-toluidine) is a critical building block in the synthesis of nitrogen-containing heterocycles. It serves as a primary substrate for gold(I)-catalyzed intramolecular hydroamination, a powerful method for constructing indole and quinoline scaffolds found in pharmaceutical agents.

The Synthetic Challenge: Selectivity

The primary challenge in synthesizing secondary amines via direct alkylation is polyalkylation. The product (N-alkyl aniline) is often more nucleophilic than the starting material (p-toluidine), leading to the formation of the undesired tertiary amine (N,N-di(but-2-ynyl)-4-methylaniline).

Core Directive: This protocol utilizes a controlled stoichiometry strategy combined with an inorganic base in an aprotic polar solvent to maximize mono-alkylation selectivity.

Experimental Design & Mechanism

Reaction Scheme

The synthesis proceeds via an

nucleophilic substitution. p-Toluidine acts as the nucleophile, displacing bromide from 1-bromo-2-butyne. Potassium carbonate (

) is employed as a scavenger base to neutralize the generated HBr, driving the equilibrium forward.

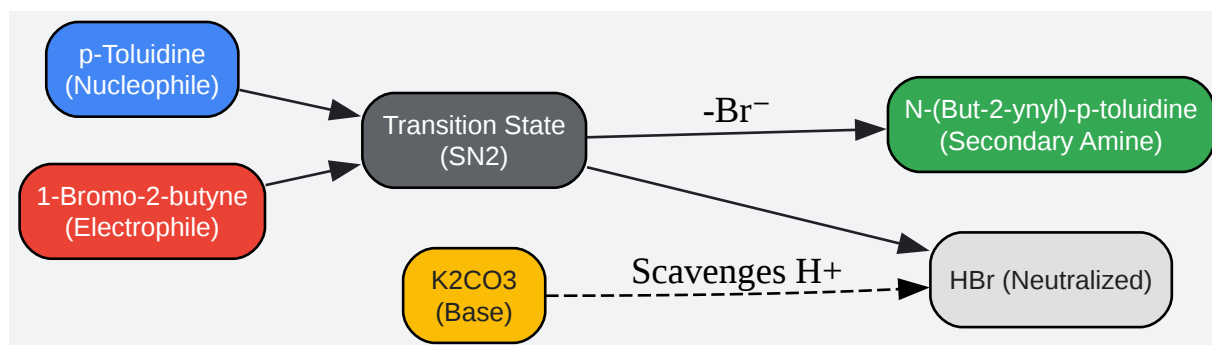

[Click to download full resolution via product page](#)

Figure 1: Mechanistic pathway for the mono-alkylation of p-toluidine.

Detailed Protocol

Materials & Reagents

Reagent	MW (g/mol)	Equiv.[1]	Amount (Example)	Role
p-Toluidine	107.16	1.2	1.28 g	Nucleophile (Excess)
1-Bromo-2-butyne	133.00	1.0	1.33 g (approx 0.88 mL)	Electrophile
Potassium Carbonate	138.21	2.0	2.76 g	Base
Acetonitrile (MeCN)	-	-	20 mL	Solvent

“

Critical Safety Note: 1-Bromo-2-butyne is a lachrymator and potential alkylating agent. Handle only in a fume hood.

Step-by-Step Procedure

- Preparation: In a 100 mL round-bottom flask equipped with a magnetic stir bar, dissolve p-toluidine (1.2 equiv) in anhydrous Acetonitrile (0.5 M concentration relative to bromide).
 - Why 1.2 equiv? A slight excess of the amine statistically favors the attack of the starting material over the product, reducing over-alkylation.
- Base Addition: Add Potassium Carbonate (2.0 equiv) to the solution. The mixture will appear as a suspension.
- Electrophile Addition: Add 1-Bromo-2-butyne (1.0 equiv) dropwise over 10 minutes at room temperature.
 - Control Point: Rapid addition increases the local concentration of electrophile, promoting double alkylation. Dropwise addition is essential.
- Reaction: Stir the mixture at 50°C for 6–8 hours. Monitor via TLC (Hexane/EtOAc 8:2).
 - Endpoint: Disappearance of the bromide spot. A small spot for p-toluidine will remain (due to excess).
- Quench & Workup:
 - Filter the reaction mixture through a celite pad to remove inorganic salts ().
 - Concentrate the filtrate under reduced pressure (Rotavap).

- Redissolve the residue in Ethyl Acetate (30 mL) and wash with water (2 x 15 mL) followed by brine (15 mL).
- Dry the organic layer over anhydrous

, filter, and concentrate.
- Purification: Purify the crude oil via flash column chromatography on silica gel.
 - Eluent: Gradient from 100% Hexane to 10% EtOAc/Hexane.
 - Order of Elution: Dialkylated byproduct (fastest)

Target Product

Unreacted p-Toluidine.

Workflow Logic

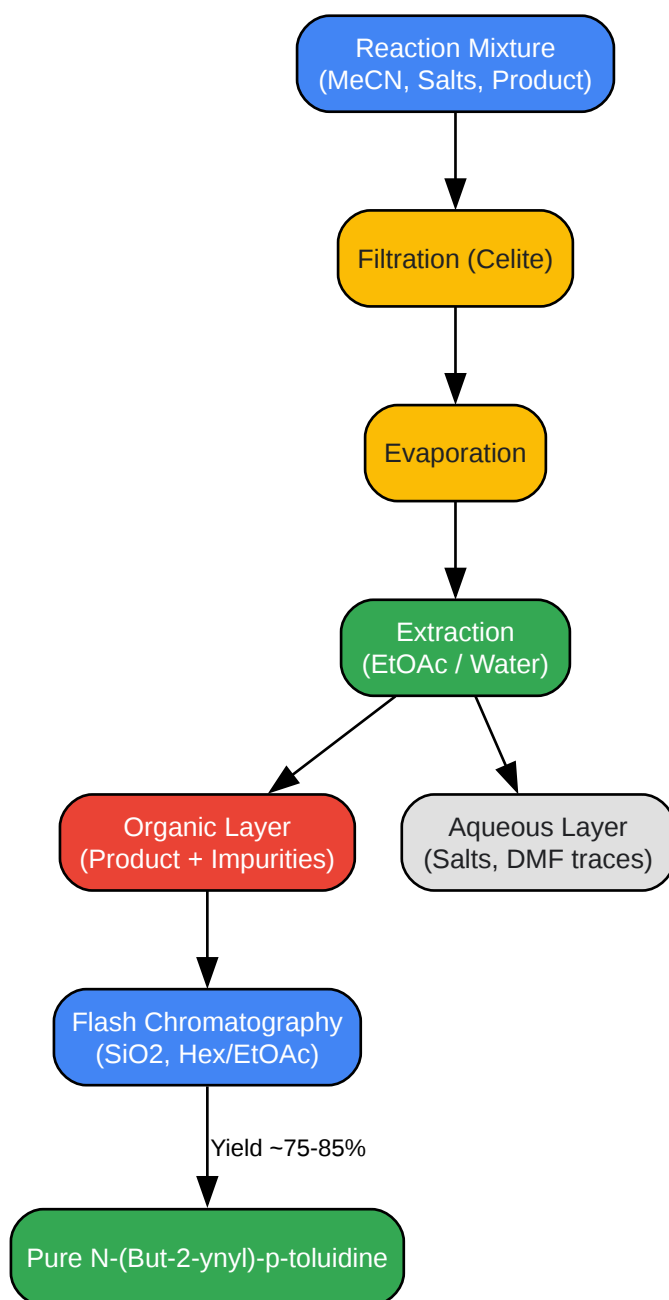

[Click to download full resolution via product page](#)

Figure 2: Purification and isolation workflow.

Validation & Characterization (Self-Validating Data)

To ensure the integrity of the synthesized compound, compare your analytical data against these expected values.

NMR Spectroscopy Data

Nucleus	Shift (ppm)	Multiplicity	Integral	Assignment
H	7.02	Doublet (Hz)	2H	Aromatic (meta to N)
H	6.58	Doublet (Hz)	2H	Aromatic (ortho to N)
H	3.86	Singlet (broad)	2H	
H	3.60	Broad Singlet	1H	(Exchangeable)
H	2.24	Singlet	3H	
H	1.80	Triplet (Hz)	3H	

Diagnostic Check:

- If the signal at 3.86 ppm integrates to 4H and the NH signal is missing, you have formed the tertiary amine (over-alkylation).
- If the triplet at 1.80 ppm is missing, check if you used propargyl bromide (terminal alkyne) instead of 1-bromo-2-butyne.

Mass Spectrometry

- Formula:
- Calculated MW: 159.23 g/mol
- Expected MS (ESI+):

References

- General N-Alkylation Protocol: Bhattacharyya, S., et al. "Selective N-alkylation of primary amines with R-NH₂-HBr and alkyl bromides using a competitive deprotonation/protonation strategy." RSC Advances, 2014, 4, 18229-18233. [Link](#)
- Gold-Catalyzed Applications: Dorel, R., & Echavarren, A. M. "Gold(I)-Catalyzed Activation of Alkynes for the Construction of Molecular Complexity." Chemical Reviews, 2015, 115(17), 9028–9079. [Link](#)
- Indole Synthesis Utility: Zhang, Y., et al. "Gold-Catalyzed Cascade Cyclization of 2-Alkynyl-N-Propargylanilines by Rearrangement of a Propargyl Group." Organic Letters, 2018.

Need Custom Synthesis?

BenchChem offers custom synthesis for rare earth carbides and specific isotopic labeling.

Email: info@benchchem.com or [Request Quote Online](#).

Sources

- [1. Indole synthesis \[organic-chemistry.org\]](#)
- To cite this document: BenchChem. [Application Note: Selective Synthesis of N-(But-2-ynyl)-4-methylaniline]. BenchChem, [2026]. [Online PDF]. Available at: [\[https://www.benchchem.com/product/b1274550/docs#application-note-selective-synthesis-of-n-but-2-ynyl-4-methylaniline\]](https://www.benchchem.com/product/b1274550/docs#application-note-selective-synthesis-of-n-but-2-ynyl-4-methylaniline)

Disclaimer & Data Validity:

The information provided in this document is for Research Use Only (RUO) and is strictly not intended for diagnostic or therapeutic procedures. While BenchChem strives to provide accurate protocols, we make no warranties, express or implied, regarding the fitness of this product for every specific experimental setup.

Technical Support: The protocols provided are for reference purposes. Unsure if this reagent suits your experiment?

Need Industrial/Bulk Grade? [Request Custom Synthesis Quote](#)

BenchChem

Our mission is to be the trusted global source of essential and advanced chemicals, empowering scientists and researchers to drive progress in science and industry.

Contact

Address: 3281 E Guasti Rd
Ontario, CA 91761, United States
Phone: (601) 213-4426
Email: info@benchchem.com

[Contact our Ph.D. Support Team for a compatibility check](#)