

Troubleshooting low yields in chromone synthesis

Author: BenchChem Technical Support Team. **Date:** May 2026

Compound of Interest

Compound Name: 3-Bromo-6-chlorochromone

CAS No.: 73220-38-9

Cat. No.: B1273435

[Get Quote](#)

Technical Support Center: Chromone Synthesis

Welcome to the technical support center for chromone synthesis. This resource is designed for researchers, scientists, and drug development professionals to navigate the common challenges encountered during the synthesis of chromone scaffolds. The chromone core is a privileged structure in medicinal chemistry, but its synthesis can be fraught with challenges leading to low yields and difficult purifications.^{[1][2]} This guide provides in-depth, field-proven insights in a direct question-and-answer format to help you troubleshoot your experiments effectively.

Frequently Asked Questions (FAQs)

This section addresses broad, high-level questions that are common starting points for troubleshooting.

Q1: My reaction yield is consistently low. What are the primary factors I should investigate?

A1: Persistently low yields in chromone synthesis typically stem from one or more of the following core areas: suboptimal reaction conditions, inappropriate catalyst/reagent choice, electronic effects of your substrates, or the formation of stable side products.[3][4]

- **Reaction Conditions:** Many classical chromone syntheses, such as the Kostanecki-Robinson or Simonis reactions, require specific, often harsh, conditions like prolonged heating.[3][5] The temperature and reaction time are critical variables that must be optimized. Modern approaches like microwave-assisted synthesis can dramatically reduce reaction times and improve yields by ensuring uniform and rapid heating.[6][7]
- **Catalyst Choice:** The selection between acid and base catalysis is fundamental and depends entirely on the synthetic route.[8] For instance, the Baker-Venkataraman rearrangement requires a strong base (e.g., KOH, NaH) to facilitate the key intramolecular acyl transfer.[4][9] In contrast, the subsequent cyclization of the resulting 1,3-diketone to the chromone is acid-catalyzed (e.g., HCl, H₂SO₄).[10][11] The specific catalyst and its concentration can be the difference between a high-yielding reaction and a complex mixture.
- **Substituent Effects:** The electronic nature of substituents on your phenolic starting material significantly impacts reactivity.[7] Electron-withdrawing groups (EWGs) can decrease the nucleophilicity of the phenol, potentially slowing down key steps and requiring more forcing conditions.[7] Conversely, electron-donating groups (EDGs) can increase reactivity but may also promote undesirable side reactions like self-condensation.[3][12]
- **Solvent Purity:** For base-catalyzed steps, the use of anhydrous aprotic solvents (e.g., THF, DMSO, dry pyridine) is often critical.[4][9] Protic solvents like water or ethanol can quench the base or cause hydrolysis of ester intermediates, halting the reaction.[9]

Q2: How can I effectively monitor the progress of my chromone synthesis?

A2: The most common and accessible method for real-time reaction monitoring is Thin-Layer Chromatography (TLC).[7] By co-spotting the reaction mixture with your starting materials on a TLC plate, you can visually track the consumption of reactants and the appearance of the product spot. For more quantitative and precise analysis, High-Performance Liquid Chromatography (HPLC) is the preferred method.[7][13] For complex mechanistic studies,

techniques like Pressurized Sample Infusion-Mass Spectrometry (PSI-ESI-MS) and in-situ NMR spectroscopy can provide detailed insights into reaction intermediates and kinetics.[14]

Q3: What are the most common side products in chromone synthesis, and how can I minimize them?

A3: Side product formation is a primary cause of low yields. The most frequent impurities are coumarins, unreacted intermediates, and products from self-condensation.

- **Coumarins:** In reactions like the Simonis synthesis, the condensation of a phenol with a β -ketoester can lead to either a chromone or a coumarin.[5][15] The choice of condensing agent is critical: phosphorus pentoxide (P_2O_5) typically favors chromone formation, whereas sulfuric acid (H_2SO_4) often yields the isomeric coumarin.[7][16]
- **Incomplete Cyclization:** In two-step syntheses like the Baker-Venkataraman rearrangement, the 1,3-diketone intermediate may fail to cyclize completely. This can be due to insufficient acid strength, low temperature, or short reaction times in the cyclization step. Ensuring the complete conversion of the intermediate is key.[3]
- **Self-Condensation:** Starting materials, particularly aldehydes used in reactions leading to chromanones, can undergo self-condensation, especially in the presence of base and with electron-donating groups on the aromatic ring.[3][12] This can be minimized by carefully controlling stoichiometry and reaction temperature.[3]

Troubleshooting Specific Synthetic Routes

Different synthetic strategies have unique failure modes. This section provides targeted advice for common named reactions used to synthesize chromones.

Issue 1: Poor Yields in the Baker-Venkataraman Rearrangement

Question: I'm performing a Baker-Venkataraman rearrangement to get my 1,3-diketone intermediate, but the yield is very low, and I recover mostly starting material. What's going wrong?

Answer: The Baker-Venkataraman rearrangement is an intramolecular acyl transfer that is highly dependent on the efficient formation of a key enolate intermediate.^{[11][17]} Low yields are almost always traced back to issues with the base, solvent, or the stability of the starting ester.

- Cause - Ineffective Deprotonation: The reaction is initiated by the abstraction of a proton alpha to the ketone.^[11] If the base is not strong enough or is used in insufficient quantity, this equilibrium will not favor the enolate, and the reaction will not proceed.
 - Solution: Use a strong base such as potassium tert-butoxide, sodium hydride (NaH), or powdered potassium hydroxide (KOH).^{[3][9]} Ensure you are using at least one full equivalent of the base, and often 2-3 equivalents are required to drive the reaction to completion.^[4]
- Cause - Solvent Issues: The presence of water or other protic solvents will quench the base and can hydrolyze your starting ester.^[9]
 - Solution: Use anhydrous aprotic solvents like dry pyridine, THF, or DMSO.^{[4][9]} Ensure all glassware is oven- or flame-dried before use and run the reaction under an inert atmosphere (e.g., Nitrogen or Argon).
- Cause - Suboptimal Temperature: While some reactive systems can proceed at room temperature, many require heating to facilitate the rearrangement.^[9]
 - Solution: Gently heat the reaction mixture. A temperature of 50 °C is often a good starting point.^{[4][10]} Monitor the reaction by TLC to avoid decomposition at higher temperatures.

Workflow: Troubleshooting the Baker-Venkataraman Rearrangement

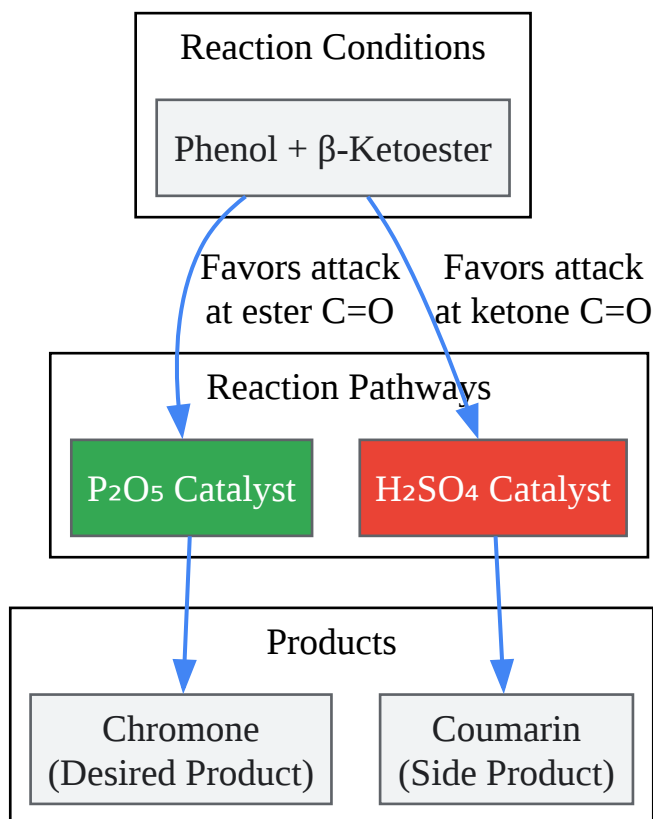
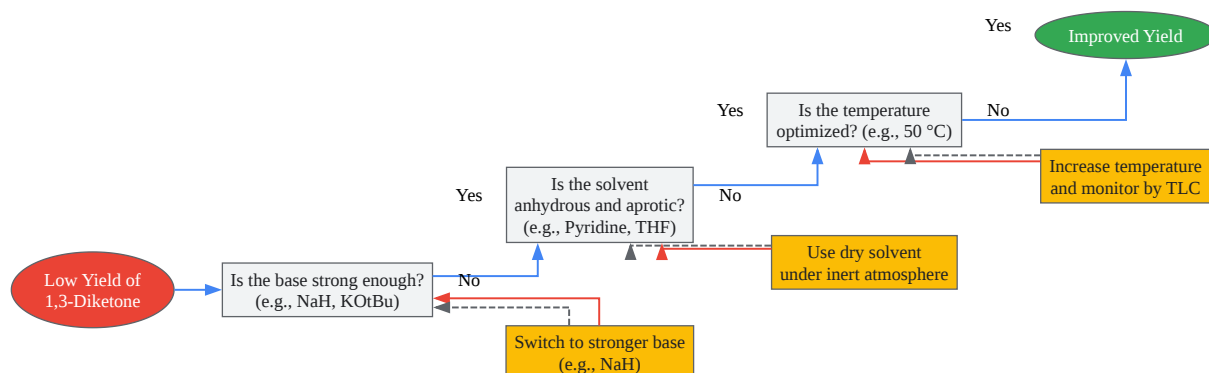

[Click to download full resolution via product page](#)

Need Custom Synthesis?

BenchChem offers custom synthesis for rare earth carbides and specific isotopic labeling.

Email: info@benchchem.com or [Request Quote Online](#).

Sources

- [1. Synthesis of Chromones and Their Applications During the Last Ten Years | Semantic Scholar \[semanticscholar.org\]](#)
- [2. asianpubs.org \[asianpubs.org\]](#)
- [3. pdf.benchchem.com \[pdf.benchchem.com\]](#)
- [4. pdf.benchchem.com \[pdf.benchchem.com\]](#)
- [5. files01.core.ac.uk \[files01.core.ac.uk\]](#)
- [6. Optimizing the Synthetic Route of Chromone-2-carboxylic Acids: A Step forward to Speed-up the Discovery of Chromone-based Multitarget-directed Ligands - PMC \[pmc.ncbi.nlm.nih.gov\]](#)
- [7. pdf.benchchem.com \[pdf.benchchem.com\]](#)
- [8. ijrpc.com \[ijrpc.com\]](#)
- [9. alfa-chemistry.com \[alfa-chemistry.com\]](#)
- [10. pdf.benchchem.com \[pdf.benchchem.com\]](#)
- [11. Baker–Venkataraman rearrangement - Wikipedia \[en.wikipedia.org\]](#)
- [12. pubs.acs.org \[pubs.acs.org\]](#)
- [13. pdf.benchchem.com \[pdf.benchchem.com\]](#)
- [14. Analytical techniques for reaction monitoring, mechanistic investigations, and metal complex discovery \[dspace.library.uvic.ca\]](#)
- [15. ijrar.org \[ijrar.org\]](#)
- [16. researchgate.net \[researchgate.net\]](#)
- [17. onlineorganicchemistrytutor.com \[onlineorganicchemistrytutor.com\]](#)
- To cite this document: BenchChem. [Troubleshooting low yields in chromone synthesis]. BenchChem, [2026]. [Online PDF]. Available at:

[<https://www.benchchem.com/product/b1273435/docs#troubleshooting-low-yields-in-chromone-synthesis>]

Disclaimer & Data Validity:

The information provided in this document is for Research Use Only (RUO) and is strictly not intended for diagnostic or therapeutic procedures. While BenchChem strives to provide accurate protocols, we make no warranties, express or implied, regarding the fitness of this product for every specific experimental setup.

Technical Support: The protocols provided are for reference purposes. Unsure if this reagent suits your experiment?

Need Industrial/Bulk Grade? [Request Custom Synthesis Quote](#)

BenchChem

Our mission is to be the trusted global source of essential and advanced chemicals, empowering scientists and researchers to drive progress in science and industry.

Contact

Address: 3281 E Guasti Rd
Ontario, CA 91761, United States
Phone: (601) 213-4426
Email: info@benchchem.com

[Contact our Ph.D. Support Team for a compatibility check](#)