

Spectral Analysis of 2-Bromo-2,2-difluoroacetamide: A Technical Guide

Author: BenchChem Technical Support Team. **Date:** May 2026

Compound of Interest

Compound Name: 2-Bromo-2,2-difluoroacetamide

CAS No.: 2169-67-7

Cat. No.: B1273100

[Get Quote](#)

This technical guide provides an in-depth analysis of the spectral data for **2-Bromo-2,2-difluoroacetamide**, a key building block in the synthesis of novel pharmaceutical and agrochemical agents. Designed for researchers, scientists, and drug development professionals, this document offers a comprehensive examination of the Nuclear Magnetic Resonance (NMR), Infrared (IR), and Mass Spectrometry (MS) data for this compound. The guide emphasizes the causal relationships behind experimental choices and provides detailed, self-validating protocols for data acquisition.

Introduction: The Structural Significance of 2-Bromo-2,2-difluoroacetamide

2-Bromo-2,2-difluoroacetamide ($C_2H_2BrF_2NO$) is a halogenated amide of significant interest in medicinal chemistry and materials science. Its unique structural features, including the electrophilic carbon center bearing both bromine and fluorine atoms, and the primary amide functionality, make it a versatile synthon for introducing the difluoromethyl group into larger molecules. Accurate and unambiguous characterization of this compound is paramount for its effective utilization in research and development. This guide provides a detailed spectroscopic roadmap for its identification and quality control.

Nuclear Magnetic Resonance (NMR) Spectroscopy

NMR spectroscopy is an indispensable tool for elucidating the precise molecular structure of **2-Bromo-2,2-difluoroacetamide**. The analysis of ^1H , ^{13}C , and ^{19}F NMR spectra provides definitive evidence for the connectivity and chemical environment of each atom in the molecule.

Predicted ^1H NMR Spectral Data

The ^1H NMR spectrum of **2-Bromo-2,2-difluoroacetamide** is predicted to be simple, exhibiting a single broad signal corresponding to the two equivalent protons of the primary amide group.

| Predicted Chemical Shift (δ) | Multiplicity | Integration | Assignment |
|---------------------------------------|---------------|-------------|------------------|
| ~7.0 - 8.0 ppm | Broad Singlet | 2H | -NH ₂ |

Expertise & Experience: The broadness of the amide proton signal is a characteristic feature resulting from quadrupole broadening by the ^{14}N nucleus and chemical exchange with trace amounts of water in the NMR solvent. The chemical shift is also highly dependent on the solvent and concentration due to varying degrees of hydrogen bonding.[1][2]

Predicted ^{13}C NMR Spectral Data

The proton-decoupled ^{13}C NMR spectrum is expected to show two distinct signals, corresponding to the carbonyl carbon and the α -carbon.

| Predicted Chemical Shift (δ) | Assignment |
|---------------------------------------|----------------------|
| ~165 - 175 ppm | C=O (Amide Carbonyl) |
| ~110 - 120 ppm (t) | CBrF ₂ |

Expertise & Experience: The carbonyl carbon of the amide is expected to appear in the typical downfield region for amides.[3] The α -carbon signal is anticipated to be a triplet due to coupling with the two directly attached fluorine atoms ($^1\text{J-CF}$). The significant downfield shift of the α -carbon is attributed to the combined electron-withdrawing effects of the bromine and two fluorine atoms.

Predicted ^{19}F NMR Spectral Data

The ^{19}F NMR spectrum will provide a direct and sensitive probe for the fluorine environment in the molecule.

| Predicted Chemical Shift (δ) | Multiplicity | Assignment |
|---------------------------------------|--------------|---------------------|
| ~ -60 to -80 ppm | Singlet | -CF ₂ Br |

Expertise & Experience: Fluorine-19 is a highly sensitive nucleus with a wide chemical shift range, making ^{19}F NMR a powerful tool.[4][5] The chemical shift of the two equivalent fluorine atoms is influenced by the electronegativity of the adjacent bromine and carbonyl group.[6] The absence of other magnetically active nuclei in close proximity (other than the quadrupolar bromine) would likely result in a singlet.

Experimental Protocol for NMR Data Acquisition

The following protocol outlines the steps for acquiring high-quality NMR spectra of **2-Bromo-2,2-difluoroacetamide**.

Diagram of NMR Workflow

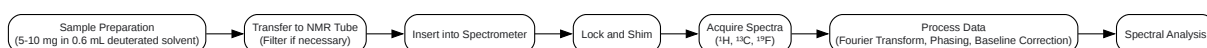

[Click to download full resolution via product page](#)

Caption: Workflow for NMR data acquisition and analysis.

Step-by-Step Methodology:

- **Sample Preparation:** Dissolve approximately 5-10 mg of **2-Bromo-2,2-difluoroacetamide** in 0.6 mL of a suitable deuterated solvent (e.g., DMSO-d₆ or CDCl₃) in a clean, dry vial.[7] Ensure complete dissolution.
- **Filtration and Transfer:** If any particulate matter is present, filter the solution through a small plug of glass wool in a Pasteur pipette directly into a clean 5 mm NMR tube.

- Spectrometer Setup: Insert the NMR tube into the spectrometer. Lock the spectrometer on the deuterium signal of the solvent and shim the magnetic field to achieve optimal homogeneity.[8]
- ^1H NMR Acquisition: Acquire the ^1H NMR spectrum using a standard pulse program. A sufficient number of scans should be averaged to obtain a good signal-to-noise ratio.
- ^{13}C NMR Acquisition: Acquire the proton-decoupled ^{13}C NMR spectrum. Due to the low natural abundance of ^{13}C , a larger number of scans and a longer relaxation delay may be necessary.[3][9]
- ^{19}F NMR Acquisition: Acquire the ^{19}F NMR spectrum. Given the high sensitivity of the ^{19}F nucleus, a relatively short acquisition time is typically required.[5][10]
- Data Processing: Process the acquired free induction decays (FIDs) by applying a Fourier transform, followed by phase and baseline correction to obtain the final spectra.[8]

Infrared (IR) Spectroscopy

FT-IR spectroscopy is employed to identify the functional groups present in **2-Bromo-2,2-difluoroacetamide**, providing valuable structural confirmation.

Predicted IR Spectral Data

The IR spectrum will be characterized by the distinct absorption bands of the primary amide group and the carbon-halogen bonds.

| Predicted Wavenumber (cm ⁻¹) | Intensity | Vibration | Assignment |
|--|---------------|--------------|---|
| 3400 - 3100 | Medium, Broad | N-H Stretch | Primary Amide (-NH ₂) [11][12] |
| 1680 - 1640 | Strong | C=O Stretch | Amide I band[11][12] |
| 1650 - 1620 | Medium | N-H Bend | Amide II band[13] |
| 1100 - 1000 | Strong | C-F Stretch | Fluorinated Alkane |
| 700 - 600 | Medium | C-Br Stretch | Brominated Alkane |

Expertise & Experience: The N-H stretching region for a primary amide typically shows two bands (asymmetric and symmetric stretches), which may be broadened due to hydrogen bonding in the solid state.[11][14] The strong carbonyl absorption (Amide I) is a hallmark of the amide functional group. The C-F and C-Br stretches appear in the fingerprint region and provide evidence for the halogenation.

Experimental Protocol for FT-IR Data Acquisition

Diagram of FT-IR Workflow

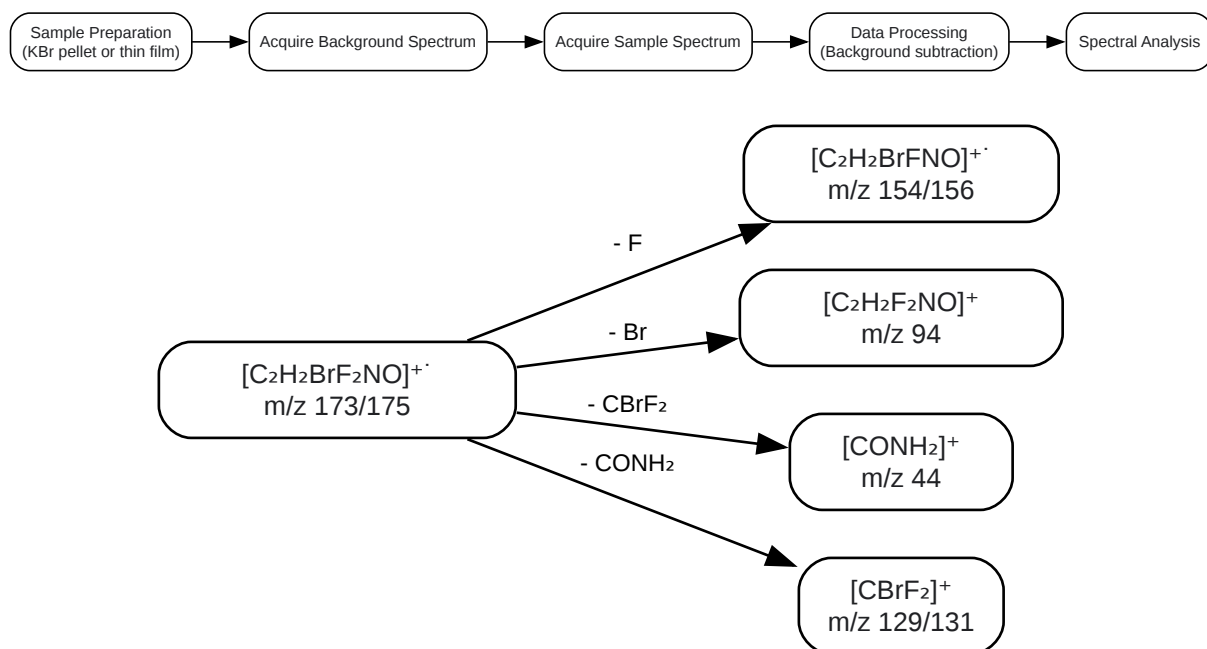

[Click to download full resolution via product page](#)

Caption: Predicted fragmentation pathway for **2-Bromo-2,2-difluoroacetamide**.

Experimental Protocol for EI-MS Data Acquisition

Diagram of EI-MS Workflow

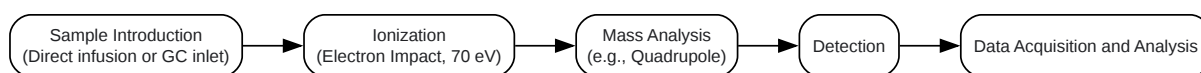

[Click to download full resolution via product page](#)

Caption: Workflow for EI-MS data acquisition and analysis.

Step-by-Step Methodology:

- **Sample Introduction:** Introduce a small amount of the sample into the mass spectrometer, either via a direct insertion probe or through a gas chromatograph (GC) inlet if the compound is sufficiently volatile and thermally stable.
- **Ionization:** The sample is bombarded with a beam of high-energy electrons (typically 70 eV) in the ion source, causing ionization and fragmentation. [15]3. **Mass Analysis:** The resulting ions are accelerated and separated based on their mass-to-charge ratio (m/z) by a mass analyzer (e.g., a quadrupole).
- **Detection:** The separated ions are detected, and their abundance is recorded.
- **Data Analysis:** The resulting mass spectrum is plotted as relative intensity versus m/z . The molecular ion and fragment ions are identified to confirm the structure of the compound. [16]

Conclusion

The comprehensive spectral analysis presented in this guide, encompassing NMR, IR, and MS techniques, provides a robust framework for the unequivocal identification and characterization of **2-Bromo-2,2-difluoroacetamide**. The predicted spectral data, grounded in established principles and data from analogous structures, serves as a reliable reference for researchers.

The detailed experimental protocols offer a standardized approach to data acquisition, ensuring reproducibility and accuracy. This technical guide is intended to be a valuable resource for scientists engaged in the synthesis, quality control, and application of this important chemical entity.

References

- University of Rochester. (n.d.). How to Get a Good ¹H NMR Spectrum. Department of Chemistry. Retrieved from [[Link](#)]
- St. Paul's Cathedral Mission College. (n.d.). INFRARED SPECTROSCOPY. Retrieved from [[Link](#)]
- LibreTexts Chemistry. (2023, March 16). 4.3: Fourier-Transform Infrared Spectroscopy (FT-IR). Retrieved from [[Link](#)]
- The Infrared Spectra of Amides. Part 1. The Stretching Vibrations of Primary Carboxamides. (2025, August 7). ResearchGate. Retrieved from [[Link](#)]
- Chemistry Steps. (n.d.). Amide infrared spectra. Retrieved from [[Link](#)]
- (n.d.). IR Chart. Retrieved from [[Link](#)]
- (n.d.). Sample preparation for FT-IR. Retrieved from [[Link](#)]
- PubChem. (n.d.). N-Bromoacetamide. Retrieved from [[Link](#)]
- Protocol for determining protein dynamics using FT-IR spectroscopy. (2023, December 2). PMC - NIH. Retrieved from [[Link](#)]
- Scribd. (n.d.). ¹³C NMR Estimation Protocol. Retrieved from [[Link](#)]
- (n.d.). ¹³-C NMR Protocol for beginners AV-400. Retrieved from [[Link](#)]
- PubChem. (n.d.). 2-Bromoacetamide. Retrieved from [[Link](#)]
- (n.d.). NMR Sample Preparation. Retrieved from [[Link](#)]

- Protocols.io. (2019, October 28). Steps for Building an Open Source EI-MS Mass Spectral Library for GC-MS -based Metabolomics. Retrieved from [\[Link\]](#)
- UCI Aerosol Photochemistry Group. (2014, June 17). Fourier Transform Infrared Spectroscopy. Retrieved from [\[Link\]](#)
- (n.d.). Fluorine NMR. Retrieved from [\[Link\]](#)
- Spectroscopy Online. (2020, January 1). Organic Nitrogen Compounds, VII: Amides—The Rest of the Story. Retrieved from [\[Link\]](#)
- Innovatech Labs. (2022, December 22). How Does FTIR Analysis Work?. Retrieved from [\[Link\]](#)
- Chemistry Steps. (n.d.). ¹³C Carbon NMR Spectroscopy. Retrieved from [\[Link\]](#)
- Oregon State University. (n.d.). ¹H NMR Chemical Shifts. Retrieved from [\[Link\]](#)
- (n.d.). ¹⁹F Fluorine NMR. Retrieved from [\[Link\]](#)
- ACS Publications. (2016, May 3). How to Compute Electron Ionization Mass Spectra from First Principles. Retrieved from [\[Link\]](#)
- AIP Publishing. (2023, April 6). Protocol for structure determination of unknowns by EI mass spectrometry. II. Diagnostic ions in one ring alicyclic, heterocyclic, and aromatic compounds. Retrieved from [\[Link\]](#)
- UCSB Chem and Biochem. (n.d.). F19 detection. Retrieved from [\[Link\]](#)
- IMSERC. (n.d.). TUTORIAL: 1D ¹H-coupled ¹⁹F SPECTRUM. Retrieved from [\[Link\]](#)
- SHIMADZU CORPORATION. (n.d.). Ionization Modes: EI. Retrieved from [\[Link\]](#)
- AIP Publishing. (2022, September 13). Protocol for Structure Determination of Unknowns by EI Mass Spectrometry. I. Diagnostic Ions for Acyclic Compounds with up to One Functional Group. Retrieved from [\[Link\]](#)

- ResearchGate. (n.d.). Fig. 4. The amide proton region of the ^1H NMR spectra: in DMSO-d 6 of.... Retrieved from [\[Link\]](#)
- KPU Pressbooks. (n.d.). 6.8 ^{13}C NMR Spectroscopy – Organic Chemistry I. Retrieved from [\[Link\]](#)
- LibreTexts Chemistry. (2022, July 20). 5.4: The ^1H -NMR experiment. Retrieved from [\[Link\]](#)
- Books. (2018, September 28). Chapter 5: Acquiring ^1H and ^{13}C Spectra. Retrieved from [\[Link\]](#)
- PMC - NIH. (2022, April 6). Practical Considerations and Guidelines for Spectral Referencing for Fluorine NMR Ligand Screening. Retrieved from [\[Link\]](#)
- ACS Publications. (n.d.). Solution NMR Measurement of Amide Proton Chemical Shift Anisotropy in ^{15}N -Enriched Proteins. Correlation with Hydrogen Bond Length. Retrieved from [\[Link\]](#)
- PMC - NIH. (n.d.). Anomalous amide proton chemical shifts as signatures of hydrogen bonding to aromatic sidechains. Retrieved from [\[Link\]](#)
- (n.d.). A GUIDE TO ^1H NMR CHEMICAL SHIFT VALUES. Retrieved from [\[Link\]](#)
- (n.d.). CONTENTS 1. ^{13}C NMR spectroscopy • Chemical shift. Retrieved from [\[Link\]](#)
- PMC - NIH. (n.d.). Fluorine-19 NMR Chemical Shift Probes Molecular Binding to Lipid Membranes. Retrieved from [\[Link\]](#)
- Western University. (n.d.). NMR Sample Preparation. Retrieved from [\[Link\]](#)
- UCSB Chem and Biochem. (n.d.). ^{19}F Chemical Shifts and Coupling Constants. Retrieved from [\[Link\]](#)
- LibreTexts Chemistry. (2014, August 6). 5.2 Mass Spectrometry. Retrieved from [\[Link\]](#)
- PubMed. (n.d.). ^{19}F NMR chemical shifts induced by a helical peptide. Retrieved from [\[Link\]](#)

- (n.d.). Mass Spectrometry (MS) Fragmentation Patterns (HL) (DP IB Chemistry): Revision Note. Retrieved from [\[Link\]](#)

Need Custom Synthesis?

BenchChem offers custom synthesis for rare earth carbides and specific isotopic labeling.

Email: info@benchchem.com or [Request Quote Online](#).

Sources

- [1. researchgate.net \[researchgate.net\]](https://www.researchgate.net)
- [2. Anomalous amide proton chemical shifts as signatures of hydrogen bonding to aromatic sidechains - PMC \[pmc.ncbi.nlm.nih.gov\]](https://pubmed.ncbi.nlm.nih.gov/)
- [3. ¹³C Carbon NMR Spectroscopy - Chemistry Steps \[chemistrysteps.com\]](https://www.chemistrysteps.com)
- [4. biophysics.org \[biophysics.org\]](https://www.biophysics.org)
- [5. ¹⁹Flourine NMR \[chem.ch.huji.ac.il\]](https://chem.ch.huji.ac.il)
- [6. alfa-chemistry.com \[alfa-chemistry.com\]](https://www.alfa-chemistry.com)
- [7. How To \[chem.rochester.edu\]](https://chem.rochester.edu)
- [8. books.rsc.org \[books.rsc.org\]](https://books.rsc.org)
- [9. 6.8 ¹³C NMR Spectroscopy – Organic Chemistry I \[kpu.pressbooks.pub\]](https://kpu.pressbooks.pub)
- [10. Practical Considerations and Guidelines for Spectral Referencing for Fluorine NMR Ligand Screening - PMC \[pmc.ncbi.nlm.nih.gov\]](https://pubmed.ncbi.nlm.nih.gov/)
- [11. spcm.ac.in \[spcm.ac.in\]](https://spcm.ac.in)
- [12. Chemistry: Amide infrared spectra \[openchemistryhelp.blogspot.com\]](https://openchemistryhelp.blogspot.com)
- [13. spectroscopyonline.com \[spectroscopyonline.com\]](https://www.spectroscopyonline.com)
- [14. researchgate.net \[researchgate.net\]](https://www.researchgate.net)
- [15. Ionization Modes: EI : SHIMADZU \(Shimadzu Corporation\) \[shimadzu.com\]](https://www.shimadzu.com)
- [16. pubs.aip.org \[pubs.aip.org\]](https://pubs.aip.org)
- To cite this document: BenchChem. [Spectral Analysis of 2-Bromo-2,2-difluoroacetamide: A Technical Guide]. BenchChem, [2026]. [Online PDF]. Available at: [\[https://www.benchchem.com/product/b1273100/docs#spectral-analysis-of-2-bromo-2-2-difluoroacetamide-a-technical-guide\]](https://www.benchchem.com/product/b1273100/docs#spectral-analysis-of-2-bromo-2-2-difluoroacetamide-a-technical-guide)

Disclaimer & Data Validity:

The information provided in this document is for Research Use Only (RUO) and is strictly not intended for diagnostic or therapeutic procedures. While BenchChem strives to provide accurate protocols, we make no warranties, express or implied, regarding the fitness of this product for every specific experimental setup.

Technical Support: The protocols provided are for reference purposes. Unsure if this reagent suits your experiment?

Need Industrial/Bulk Grade? [Request Custom Synthesis Quote](#)

BenchChem

Our mission is to be the trusted global source of essential and advanced chemicals, empowering scientists and researchers to drive progress in science and industry.

Contact

Address: 3281 E Guasti Rd
Ontario, CA 91761, United States
Phone: (601) 213-4426
Email: info@benchchem.com

[Contact our Ph.D. Support Team for a compatibility check](#)