

Synthesis of Lead Chromate Nanowires for Electronic Applications: Application Notes and Protocols

Author: BenchChem Technical Support Team. **Date:** May 2026

Compound of Interest

Compound Name: *Chrome Orange*

CAS No.: *85188-12-1*

Cat. No.: *B12721388*

[Get Quote](#)

For Researchers, Scientists, and Drug Development Professionals

This document provides detailed application notes and protocols for the synthesis of lead chromate (PbCrO_4) nanowires, materials with promising applications in the field of electronics. The following sections detail the synthesis methodologies, quantitative properties of the nanowires, and a general overview of their application in sensing devices.

Introduction

Lead chromate, a monoclinic crystalline material, has garnered significant interest for its unique electronic and optical properties at the nanoscale.[1][2] As one-dimensional nanostructures, lead chromate nanowires offer a high surface-area-to-volume ratio, making them suitable for various electronic applications, including sensors and photodetectors.[2] This document outlines established methods for the synthesis of these nanowires, providing researchers with the necessary protocols to fabricate these materials in a laboratory setting.

Experimental Protocols

Two primary methods for the synthesis of lead chromate nanowires are detailed below: a room-temperature solution-phase synthesis and a microwave-assisted synthesis.

Protocol 1: Room-Temperature Solution-Phase Synthesis

This method allows for the large-scale synthesis of single-crystalline lead chromate nanorods and nanowires without the need for surfactants or polymers.[3]

Materials:

- Lead (II) nitrate ($\text{Pb}(\text{NO}_3)_2$)
- Potassium chromate (K_2CrO_4)
- Deionized (DI) water

Equipment:

- Beakers
- Magnetic stirrer
- Centrifuge
- Drying oven

Procedure:

- Precursor Solution Preparation:
 - Prepare a 0.1 M aqueous solution of lead (II) nitrate. .
 - Prepare a 0.1 M aqueous solution of potassium chromate.
- Reaction:

- In a beaker, place a specific volume of the lead (II) nitrate solution.
- While stirring vigorously, add an equal volume of the potassium chromate solution dropwise.
- A yellow precipitate of lead chromate will form immediately.
- Continue stirring the solution at room temperature for 2-4 hours to ensure a complete reaction and crystallization.
- Purification:
 - Collect the precipitate by centrifugation at 5000 rpm for 10 minutes.
 - Discard the supernatant.
 - Wash the precipitate by re-dispersing it in deionized water and centrifuging again. Repeat this washing step three times to remove any unreacted ions.
 - Finally, wash the precipitate with ethanol to remove excess water.
- Drying:
 - Dry the purified lead chromate nanowires in an oven at 60-80°C for several hours.

Protocol 2: Microwave-Assisted Synthesis

This method offers a rapid route to synthesize lead chromate nanorods.[4] The morphology of the product can be controlled by adjusting the reaction temperature and the presence of a base.[4]

Materials:

- Lead (II) acetate ($\text{Pb}(\text{CH}_3\text{COO})_2$)
- Potassium dichromate ($\text{K}_2\text{Cr}_2\text{O}_7$)
- Sodium hydroxide (NaOH) (optional, for morphology control)

- Deionized (DI) water

Equipment:

- Microwave reactor
- Reaction vessels (microwave-safe)
- Magnetic stirrer
- Centrifuge
- Drying oven

Procedure:

- Precursor Solution Preparation:
 - Prepare an aqueous solution of lead (II) acetate.
 - Prepare an aqueous solution of potassium dichromate.
- Reaction for PbCrO_4 Rods:
 - Mix the lead acetate and potassium dichromate solutions in a microwave-safe reaction vessel.
 - Place the vessel in a microwave reactor and heat to 50°C for 10 minutes.[4]
- Reaction for Pb_2CrO_5 Rods (Alternative Phase):
 - To synthesize dilead pentaoxochromate (Pb_2CrO_5) rods, add sodium hydroxide to the precursor solution mixture.
 - Heat the solution in the microwave reactor to 90°C for 10 minutes.[4]
- Purification and Drying:
 - Follow the same purification and drying steps as outlined in Protocol 2.1 (steps 3 and 4).

Data Presentation

The physical and electronic properties of synthesized lead chromate nanostructures are summarized in the tables below.

Table 1: Morphological and Structural Properties of Lead Chromate Nanowires/Nanorods

| Synthesis Method | Morphology | Dimensions | Crystal Structure | Reference |
|--------------------------------|----------------------|---|--------------------|-----------|
| Aqueous Solution | Nanorods & Nanowires | Length: several μm , Diameter: 50-200 nm | Monoclinic | [1] |
| Microwave-Assisted | Rods | - | Single-crystalline | [4] |
| Co-precipitation with Tween-80 | Nanorods | 37.8 - 51.9 nm | Monoclinic | [5] |
| Chemical Co-precipitation | Nanoparticles | ~ 70.4 nm | Tetrahedral | [6][7] |

Table 2: Electronic and Optical Properties of Lead Chromate Nanostructures

| Property | Value | Conditions | Reference |
|-------------------------------------|--------------------------------|------------------------------|-----------|
| Dielectric Constant (ϵ') | ~ 2400 | 120°C , 100 Hz | [2] |
| Polarization Value | $0.26 \mu\text{C}/\text{cm}^2$ | Applied field of 4.0 kV/mm | [2] |
| Band Gap | 4.4 eV | - | [6] |

Visualizations

The following diagrams illustrate the experimental workflow for the synthesis of lead chromate nanowires and a general schematic for a nanowire-based sensor.

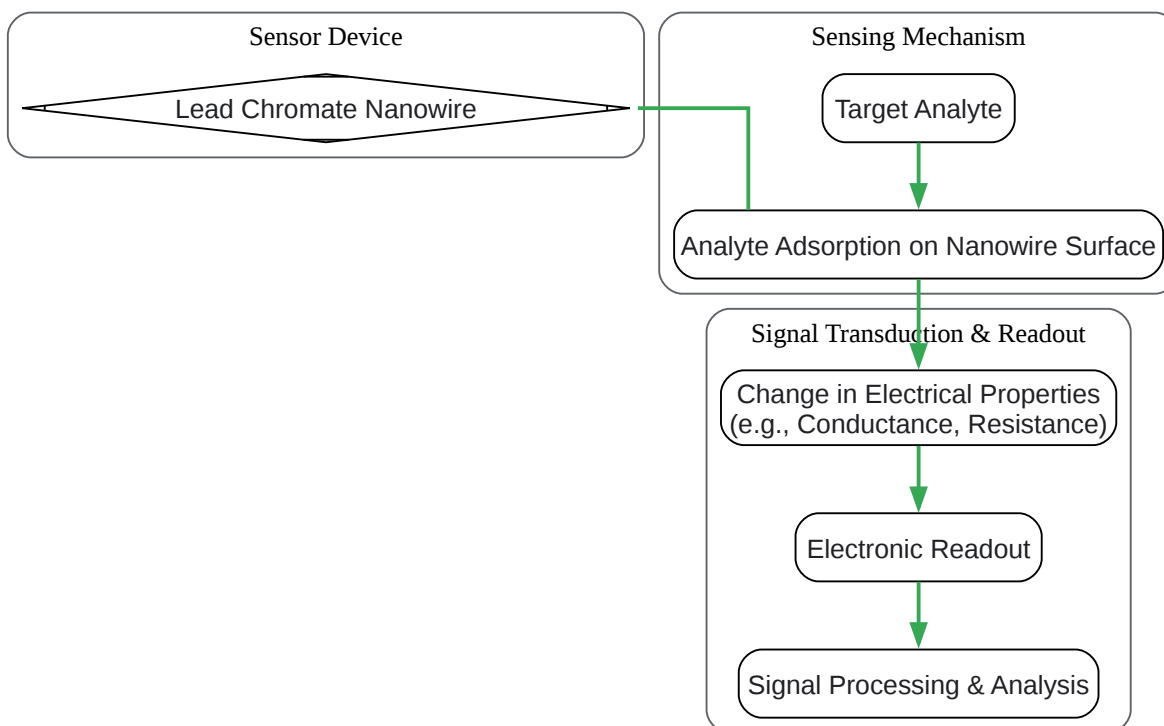
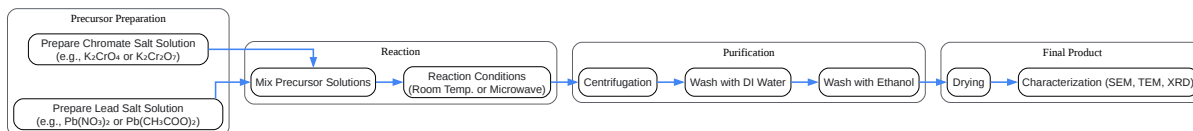

[Click to download full resolution via product page](#)

Need Custom Synthesis?

BenchChem offers custom synthesis for rare earth carbides and specific isotopic labeling.

Email: info@benchchem.com or [Request Quote Online](#).

References

- [1. researchgate.net \[researchgate.net\]](#)
- [2. d-nb.info \[d-nb.info\]](#)
- [3. academic.oup.com \[academic.oup.com\]](#)
- [4. researchgate.net \[researchgate.net\]](#)
- [5. researchgate.net \[researchgate.net\]](#)
- [6. Synthesis And Characterization Of Lead Chromate Nanoparticles, IJSR - International Journal of Scientific Research\(IJSR\), IJSR | World Wide Journals \[worldwidejournals.com\]](#)
- [7. worldwidejournals.com \[worldwidejournals.com\]](#)
- To cite this document: BenchChem. [Synthesis of Lead Chromate Nanowires for Electronic Applications: Application Notes and Protocols]. BenchChem, [2026]. [Online PDF]. Available at: [<https://www.benchchem.com/product/b12721388/docs#synthesis-of-lead-chromate-nanowires-for-electronic-applications-application-notes-and-protocols>]

Disclaimer & Data Validity:

The information provided in this document is for Research Use Only (RUO) and is strictly not intended for diagnostic or therapeutic procedures. While BenchChem strives to provide accurate protocols, we make no warranties, express or implied, regarding the fitness of this product for every specific experimental setup.

Technical Support: The protocols provided are for reference purposes. Unsure if this reagent suits your experiment?

Need Industrial/Bulk Grade? [Request Custom Synthesis Quote](#)

BenchChem

Our mission is to be the trusted global source of essential and advanced chemicals, empowering scientists and researchers to drive progress in science and industry.

Contact

Address: 3281 E Guasti Rd

Ontario, CA 91761, United States

Phone: (601) 213-4426

Email: info@benchchem.com

[Contact our Ph.D. Support Team for a compatibility check](#)