

**Application Notes & Protocols: Synthesis of GABA-A Receptor Agon

Author: BenchChem Technical Support Team. **Date:** May 2026

Compound of Interest

Compound Name: 3-Bromo-5-aminomethylisoxazole

CAS No.: 2763-93-1

Cat. No.: B1272057

[Get Quote](#)

ists from Isoxazole Precursors**

For Researchers, Scientists, and Drug Development Professionals

Abstract

The γ -aminobutyric acid type A (GABA-A) receptor, a ligand-gated ion channel, is a principal mediator of inhibitory neurotransmission in the central nervous system (CNS).[1][2] Its modulation is a cornerstone of therapeutic intervention for a spectrum of neurological and psychiatric disorders, including anxiety, epilepsy, and sleep disturbances. Isoxazole derivatives, particularly those structurally analogous to the native ligand GABA, have emerged as a privileged scaffold in the design of potent and selective GABA-A receptor agonists.[3][4] This document provides a comprehensive guide to the synthesis of key isoxazole-based GABA-A agonists, with a focus on muscimol and gaboxadol (THIP). We will explore the underlying chemical principles, provide detailed, field-tested protocols, and discuss the structure-activity relationships (SAR) that govern the interaction of these synthetic ligands with their biological target.

Introduction: The Isoxazole Scaffold in GABA-A Receptor Modulation

The GABA-A receptor is a heteropentameric chloride ion channel with a rich pharmacology.[1] [5] The orthosteric binding site, where GABA and its analogs bind, exhibits stringent structural and stereochemical requirements for activation.[1] The isoxazole ring, particularly the 3-isoxazolol moiety, serves as an effective bioisosteric replacement for the carboxylic acid group of GABA, while the aminomethyl side chain mimics the amino group of the endogenous neurotransmitter.[6] This structural mimicry allows isoxazole-based compounds like muscimol to act as potent agonists at the GABA binding site.[4][7]

Muscimol, a psychoactive isoxazole found in *Amanita muscaria* mushrooms, is a powerful GABA-A receptor agonist and has been instrumental as a research tool in neuroscience.[4][7] Gaboxadol (4,5,6,7-tetrahydroisoxazolo[5,4-c]pyridin-3-ol, THIP), a bicyclic analog of muscimol, also demonstrates potent GABA-A agonistic activity.[3][8] The synthesis of these and related compounds from isoxazole precursors is a key area of medicinal chemistry research aimed at developing novel therapeutics with improved selectivity and pharmacokinetic profiles.[1][3]

Key Advantages of the Isoxazole Scaffold:

- **Bioisosteric Mimicry:** The 3-hydroxyisoxazole moiety effectively mimics the carboxylate group of GABA.[6]
- **Structural Rigidity:** The isoxazole ring introduces conformational constraints, which can enhance binding affinity and selectivity for specific GABA-A receptor subtypes.
- **Synthetic Tractability:** The isoxazole ring can be synthesized through various established methods, including 1,3-dipolar cycloaddition reactions, allowing for diverse substitutions and the generation of compound libraries for SAR studies.[9][10]

Core Synthetic Strategies

The synthesis of isoxazole-based GABA-A agonists generally involves two key stages: the construction of the core isoxazole ring and the subsequent elaboration of the side chains to introduce the necessary pharmacophoric elements.

Construction of the Isoxazole Ring

A prevalent and versatile method for synthesizing the isoxazole nucleus is the [3+2] cycloaddition reaction between a nitrile oxide and an alkyne.[9] This reaction allows for the regioselective formation of 3,5-disubstituted isoxazoles.

Diagram of the [3+2] Cycloaddition Pathway:

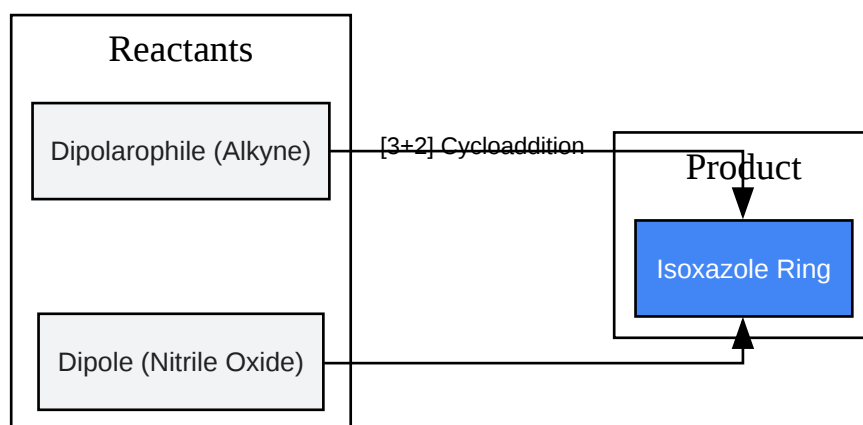

[Click to download full resolution via product page](#)

Caption: General scheme of isoxazole synthesis via [3+2] cycloaddition.

Alternative strategies include the reaction of β -ketonitriles with hydroxylamine to yield 3-aminoisoxazoles.[10] The choice of synthetic route is often dictated by the desired substitution pattern on the isoxazole ring and the availability of starting materials.

Elaboration of Functional Groups

Once the isoxazole core is established, subsequent chemical transformations are required to introduce the aminomethyl side chain and other functionalities necessary for GABA-A receptor agonism. These transformations often involve:

- Reduction of Esters or Carboxylic Acids: Conversion of an ester or carboxylic acid at the 5-position of the isoxazole to the corresponding alcohol, followed by conversion to an amine.
- Protection/Deprotection Strategies: The use of protecting groups for the amine and hydroxyl functionalities is often necessary to prevent unwanted side reactions during the synthesis.

Detailed Synthetic Protocols

The following protocols are provided as illustrative examples for the synthesis of key isoxazole-based GABA-A agonists. Researchers should adapt these protocols based on their specific laboratory conditions and available instrumentation.

Protocol 1: Synthesis of Muscimol from Ibotenic Acid

Muscimol can be synthesized from ibotenic acid, a naturally occurring amino acid found in Amanita species, through a straightforward decarboxylation reaction.^{[7][11]}

Experimental Workflow:

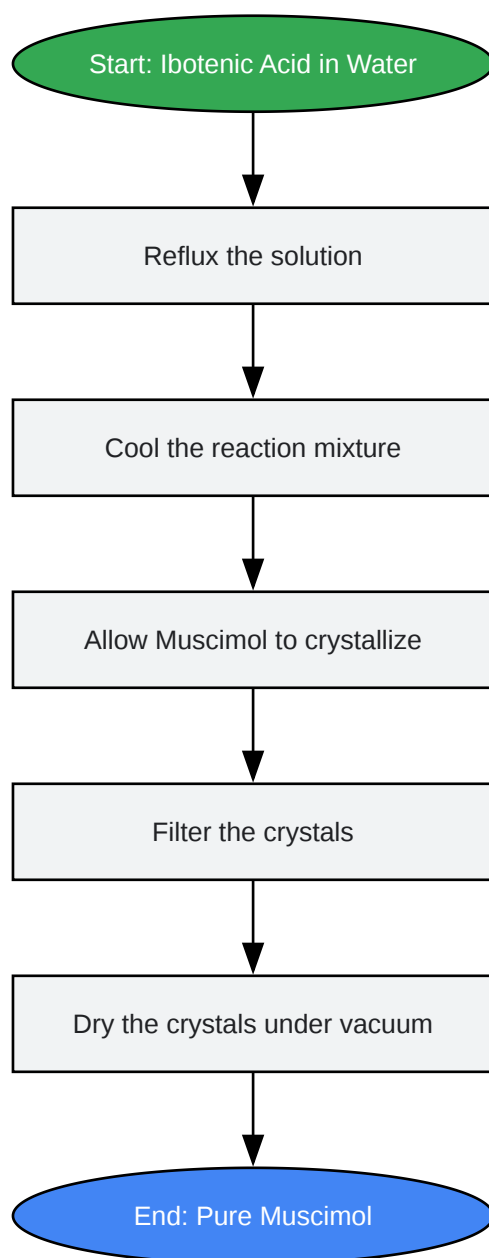

[Click to download full resolution via product page](#)

Caption: Workflow for the synthesis of Muscimol from Ibotenic Acid.

Step-by-Step Methodology:

- Dissolution: Dissolve ibotenic acid in approximately 10 times its weight of deionized water in a round-bottom flask equipped with a reflux condenser.[11]

- Decarboxylation: Heat the solution to reflux. The decarboxylation of ibotenic acid to muscimol will occur. Monitor the reaction progress by thin-layer chromatography (TLC).
- Crystallization: Once the reaction is complete (typically after several hours), remove the heat source and allow the solution to cool slowly to room temperature, and then further in an ice bath to facilitate the crystallization of muscimol.
- Isolation: Collect the crystalline muscimol by vacuum filtration and wash with a small amount of cold water.
- Drying: Dry the purified muscimol under vacuum to a constant weight.

Characterization: The final product should be characterized by Nuclear Magnetic Resonance (NMR) spectroscopy, Mass Spectrometry (MS), and melting point determination to confirm its identity and purity.[9]

Protocol 2: Multi-step Synthesis of Gaboxadol (THIP)

The synthesis of gaboxadol is more complex and involves the construction of the bicyclic ring system. A common route starts from pyrrolidin-2-one.[8]

Key Intermediate Synthesis Pathway:

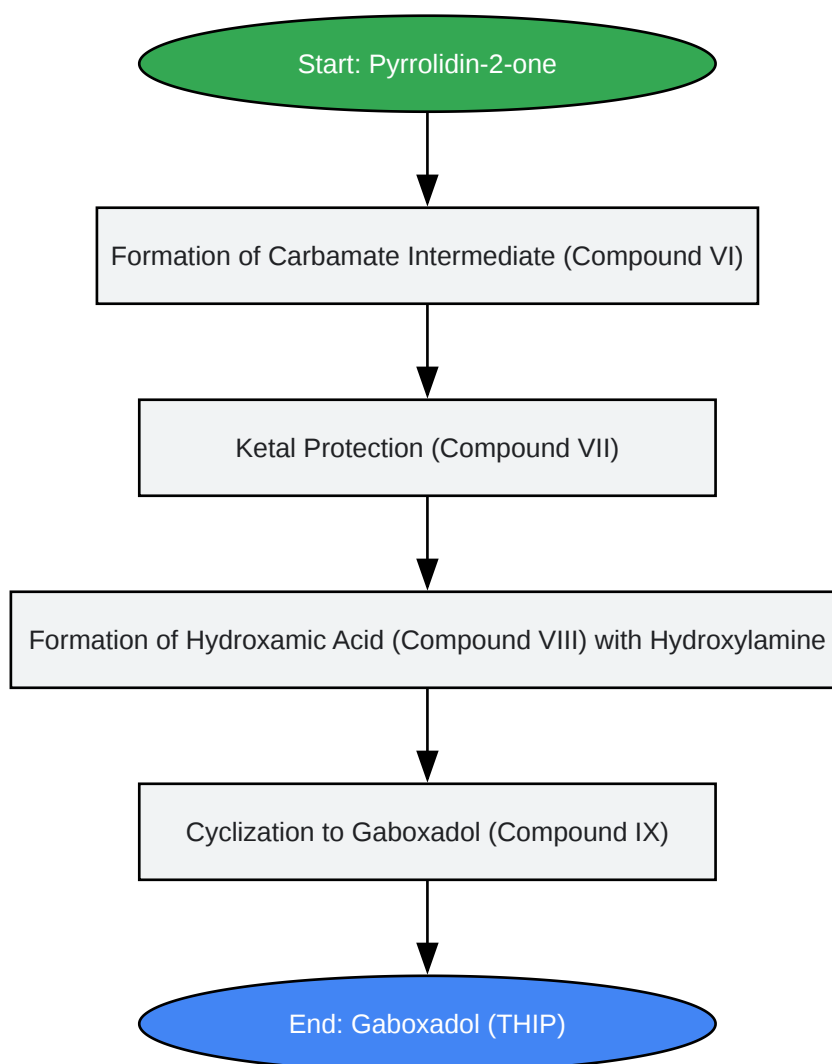

[Click to download full resolution via product page](#)

Caption: Simplified synthetic pathway to Gaboxadol.

Detailed Step-by-Step Methodology (Conceptual Outline):

- Step 1: Formation of the Carbamate Intermediate: A key step involves the formation of a carbamate intermediate, such as dimethyl 5-hydroxy-3,6-dihydropyridine-1,4(2H)-dicarboxylate, from pyrrolidin-2-one.[8] This transformation establishes the core piperidine ring of gaboxadol.
- Step 2: Protection of the Ketone: The keto-enol tautomerism of the intermediate allows for the protection of the ketone as a ketal, for instance, using ethylene glycol.[8]

- Step 3: Formation of the Hydroxamic Acid: The protected intermediate is then reacted with hydroxylamine to form the corresponding hydroxamic acid.[8] This introduces the N-OH functionality required for the isoxazole ring.
- Step 4: Cyclization to Form the Isoxazole Ring: The final step involves an acid-catalyzed cyclization of the hydroxamic acid to form the fused isoxazole ring of gaboxadol.[8]

Note: The specific reagents and reaction conditions for each step can be found in the cited patent literature (EP 0000338) and related publications.[8]

Structure-Activity Relationship (SAR) Insights

The pharmacological profile of isoxazole-based GABA-A agonists is highly dependent on their chemical structure.

Compound	Key Structural Feature	GABA-A Receptor Activity	Reference
Muscimol	5-aminomethyl-3-isoxazolol	Potent agonist	[4][7]
Gaboxadol (THIP)	Bicyclic (fused piperidine ring)	Potent agonist	[3][8]
4-PIOL	5-(4-piperidyl)-3-isoxazolol	Agonist, with derivatives showing subtype selectivity	[1]
Guvacine	Tetrahydropyridine carboxylic acid	GABA uptake inhibitor	
Isoguvacine	Tetrahydropyridine carboxylic acid	GABA-A agonist	

Key SAR Observations:

- The 3-isoxazolol moiety is crucial for agonist activity, acting as a bioisostere of the GABA carboxylate group.[6]

- The aminomethyl side chain at the 5-position is essential for binding to the GABA site. Modifications to this chain can significantly alter potency and efficacy.
- Conformational restriction, as seen in gaboxadol, can lead to enhanced selectivity for certain GABA-A receptor subtypes.[3]
- Substitutions on the isoxazole ring or the side chain can be explored to fine-tune the pharmacological properties, including potency, efficacy, and subtype selectivity.[1][6]

Characterization and Quality Control

The purity and identity of the synthesized compounds are critical for obtaining reliable pharmacological data. The following analytical techniques are essential for characterization:

- Nuclear Magnetic Resonance (NMR) Spectroscopy (^1H and ^{13}C): To confirm the chemical structure and assess purity.[9][12]
- Mass Spectrometry (MS): To determine the molecular weight of the compound.[9][13]
- Infrared (IR) Spectroscopy: To identify key functional groups.[9][13]
- High-Performance Liquid Chromatography (HPLC): To determine the purity of the final compound.[13]
- Melting Point Determination: As an indicator of purity.[9]
- Elemental Analysis: To confirm the elemental composition.[13]

Conclusion

The synthesis of GABA-A receptor agonists from isoxazole precursors represents a vibrant and impactful area of medicinal chemistry. The protocols and principles outlined in this guide provide a solid foundation for researchers to synthesize and explore novel isoxazole-based compounds. A thorough understanding of the synthetic methodologies, coupled with a rational approach to structure-activity relationship studies, will continue to drive the development of next-generation therapeutics targeting the GABA-A receptor.

References

- Synthesis of Muscimole - Erowid. [\[Link\]](#)
- Synthesis of GABAA Receptor Agonists and Evaluation of their α -Subunit Selectivity and Orientation in the GABA Binding Site - PMC. [\[Link\]](#)
- Synthesis, Characterization And Biological Activity Of Isoxazole Derivatives - IJCRT.org. [\[Link\]](#)
- WO2016150953A1 - Manufacture of 4,5,6,7-tetrahydroisoxazolo[5,4-c]pyridin-3-ol - Google P
- Synthesis of [3H]muscimol - PMC - PubMed Central - NIH. [\[Link\]](#)
- GABA Receptor Agonists. Synthesis of Muscimol Analogues Including (R)- and (S)-5-(1-Aminoethyl)-3-isoxazolol and (RS)-5-Aminomethyl-2-isoxazolin-3-ol. - ResearchGate. [\[Link\]](#)
- The Green and Effective Synthesis of Isoxazole-Based Molecules Under Ultrasonic Irradiation Approaches - MDPI. [\[Link\]](#)
- Psychoactive Isoxazoles, Muscimol, and Isoxazole Derivatives from the Amanita (Agaricomycetes) Species: Review of New Trends in Synthesis, Dosage, and Biological Properties - PubMed. [\[Link\]](#)
- Classics in Chemical Neuroscience: Muscimol - ACS Publications. [\[Link\]](#)
- Psychoactive Isoxazoles, Muscimol and Isoxazole derivatives from the Amanita (Agaricomycetes) Species. New Trends in Synthesis, Dosage, and Biological Properties: A Review | Request PDF - ResearchGate. [\[Link\]](#)
- Synthesis, characterization and antimicrobial evaluation of isoxazole derivatives - Der Pharma Chemica. [\[Link\]](#)
- GABA receptor agonists: relationship between structure and biological activity in vivo and in vitro - PubMed. [\[Link\]](#)

- Synthesis and characterization of a novel gamma-aminobutyric acid type A (GABAA) receptor ligand that combines outstanding metabolic stability, pharmacokinetics, and anxiolytic efficacy - PubMed Central. [\[Link\]](#)
- The synthetic and therapeutic expedition of isoxazole and its analogs - PMC. [\[Link\]](#)
- (PDF) Synthesis, characterization of isoxazole derivatives and evaluation of their antibacterial, antioxidant and anticancer activity - ResearchGate. [\[Link\]](#)
- Regulating AMPA Receptors with Isoxazole-4-Carboxamide Derivatives: An Electrophysiological Study - MDPI. [\[Link\]](#)
- A novel class of potent 3-isoxazolol GABA(A) antagonists: design, synthesis, and pharmacology - PubMed. [\[Link\]](#)
- CA2759598C - Isoxazole-thiazole derivatives as gaba a receptor inverse agonists for use in the treatment of cognitive disorders - Google P
- Synthesis of New GABAA Receptor Modulator with Pyrazolo[1,5-a]quinazoline (PQ) Scaffold. [\[Link\]](#)
- Design, synthesis, characterization and antimicrobial evaluation of isoxazole derivatives - Scholars Research Library. [\[Link\]](#)
- A review of isoxazole biological activity and present synthetic techniques. [\[Link\]](#)
- Structure-activity Relationships of Neuroactive Steroids Acting on the GABAA Receptor. [\[Link\]](#)
- Synthesis and Receptor Binding Studies of $\alpha 5$ GABAAR Selective Novel Imidazodiazepines Targeted for Psychiatric and Cognitive Disorders - MDPI. [\[Link\]](#)
- GABA receptor agonists: pharmacological spectrum and therapeutic actions - PubMed. [\[Link\]](#)
- Binding modes and basis of $\alpha 5$ selectivity of isoxazole compounds a,... - ResearchGate. [\[Link\]](#)

- Isoxazole/Isoxazoline Skeleton in the Structural Modification of Natural Products: A Review - MDPI. [\[Link\]](#)
- GABA receptor agonist - Wikipedia. [\[Link\]](#)
- Advances in isoxazole chemistry and their role in drug discovery - RSC Publishing. [\[Link\]](#)
- The Green and Effective Synthesis of Isoxazole-Based Molecules Under Ultrasonic Irradiation Approaches - PubMed Central. [\[Link\]](#)
- Isoxazole synthesis - Organic Chemistry Portal. [\[Link\]](#)
- Synthesis of Fused Isoxazoles: A Comprehensive Review - MDPI. [\[Link\]](#)

Need Custom Synthesis?

BenchChem offers custom synthesis for rare earth carbides and specific isotopic labeling.

Email: info@benchchem.com or [Request Quote Online](#).

Sources

1. Synthesis of GABAA Receptor Agonists and Evaluation of their α -Subunit Selectivity and Orientation in the GABA Binding Site - PMC [pubmed.ncbi.nlm.nih.gov]
2. GABA receptor agonist - Wikipedia [en.wikipedia.org]
3. Psychoactive Isoxazoles, Muscimol, and Isoxazole Derivatives from the Amanita (Agaricomycetes) Species: Review of New Trends in Synthesis, Dosage, and Biological Properties - PubMed [pubmed.ncbi.nlm.nih.gov]
4. pubs.acs.org [pubs.acs.org]
5. mdpi.com [mdpi.com]
6. researchgate.net [researchgate.net]
7. Synthesis of [^3H]muscimol - PMC [pubmed.ncbi.nlm.nih.gov]
8. WO2016150953A1 - Manufacture of 4,5,6,7-tetrahydroisoxazolo[5,4-c]pyridin-3-ol - Google Patents [patents.google.com]
9. ijcrt.org [ijcrt.org]

- [10. The synthetic and therapeutic expedition of isoxazole and its analogs - PMC \[pmc.ncbi.nlm.nih.gov\]](#)
- [11. Synthesis of Muscimole \[erowid.org\]](#)
- [12. researchgate.net \[researchgate.net\]](#)
- [13. derpharmachemica.com \[derpharmachemica.com\]](#)
- To cite this document: BenchChem. [****Application Notes & Protocols: Synthesis of GABA-A Receptor Agon**]. BenchChem, [2026]. [Online PDF]. Available at: [\[https://www.benchchem.com/product/b1272057/docs#application-notes-protocols-synthesis-of-gaba-a-receptor-agon\]](https://www.benchchem.com/product/b1272057/docs#application-notes-protocols-synthesis-of-gaba-a-receptor-agon)

Disclaimer & Data Validity:

The information provided in this document is for Research Use Only (RUO) and is strictly not intended for diagnostic or therapeutic procedures. While BenchChem strives to provide accurate protocols, we make no warranties, express or implied, regarding the fitness of this product for every specific experimental setup.

Technical Support: The protocols provided are for reference purposes. Unsure if this reagent suits your experiment?

Need Industrial/Bulk Grade? [Request Custom Synthesis Quote](#)

BenchChem

Our mission is to be the trusted global source of essential and advanced chemicals, empowering scientists and researchers to drive progress in science and industry.

Contact

Address: 3281 E Guasti Rd
Ontario, CA 91761, United States
Phone: (601) 213-4426
Email: info@benchchem.com

Contact our Ph.D. Support Team for a compatibility check