

# The Pivotal Role of 1-Butyl-4-iodobenzene in Advancing Organic Electronics

**Author:** BenchChem Technical Support Team. **Date:** December 2025

## Compound of Interest

Compound Name: 1-Butyl-4-iodobenzene

Cat. No.: B1271667

[Get Quote](#)

An In-depth Technical Guide for Researchers and Drug Development Professionals

Introduction: **1-Butyl-4-iodobenzene**, a halogenated aromatic compound, has emerged as a crucial building block in the synthesis of advanced organic electronic materials. Its unique molecular structure, featuring a reactive iodine atom and a solubilizing butyl group, makes it an ideal precursor for creating high-performance polymers for a range of applications, including organic field-effect transistors (OFETs), organic photovoltaics (OPVs), and organic light-emitting diodes (OLEDs). This technical guide provides a comprehensive overview of the applications of **1-butyl-4-iodobenzene** in organic electronics, detailing the synthesis of key polymers, their optoelectronic properties, and their performance in electronic devices.

## From Monomer to High-Performance Polymer: The Synthetic Pathway

The primary application of **1-butyl-4-iodobenzene** in organic electronics lies in its use as a monomer for the synthesis of hole-transporting polymers. The most prominent among these is poly(N-(4-butylphenyl)diphenylamine), often referred to as poly(4-butyltriphenylamine) (PTPA). The synthesis typically proceeds through a Suzuki coupling reaction, a versatile palladium-catalyzed cross-coupling method ideal for creating carbon-carbon bonds.

A key derivative of **1-butyl-4-iodobenzene** for this purpose is 4-butyl-N,N-bis(4-bromophenyl)aniline. This monomer, which can be synthesized from **1-butyl-4-iodobenzene**,

is then polymerized with a suitable comonomer, such as 9,9-dioctylfluorene-2,7-diboronic acid bis(1,3-propanediol) ester, to yield copolymers with tailored properties.

Experimental Protocol: Synthesis of Poly(9,9-dioctylfluorene-co-N-(4-butylphenyl)diphenylamine) (TFB)

A representative experimental protocol for the synthesis of a copolymer incorporating the 4-butylphenyl)diphenylamine moiety via Suzuki coupling is as follows:

- **Monomer Preparation:** Synthesize or procure 2,7-dibromo-9,9-dioctylfluorene and N,N-diphenyl-N-(4-butylphenyl)amine. The latter can be prepared through the Buchwald-Hartwig amination of **1-butyl-4-iodobenzene** with diphenylamine.
- **Borylation of Fluorene Monomer:** The 2,7-dibromo-9,9-dioctylfluorene is converted to its corresponding diboronic acid or ester derivative.
- **Polymerization:**
  - In an inert atmosphere (e.g., under argon), a mixture of the fluorene diboronic ester, N,N-bis(4-bromophenyl)-4-butylaniline, a palladium catalyst such as tetrakis(triphenylphosphine)palladium(0) [Pd(PPh<sub>3</sub>)<sub>4</sub>], and a base (e.g., aqueous sodium carbonate or potassium carbonate) is dissolved in a suitable solvent system, typically a mixture of toluene and water.
  - The reaction mixture is heated to reflux (around 80-100 °C) and stirred for a period ranging from 24 to 72 hours, until the desired molecular weight is achieved.
  - The polymerization is quenched, and the resulting polymer is precipitated by adding the reaction mixture to a non-solvent like methanol.
  - The polymer is then purified through repeated washing and reprecipitation to remove catalyst residues and low molecular weight oligomers.

## Core Applications in Organic Electronic Devices

Polymers derived from **1-butyl-4-iodobenzene**, particularly copolymers like Poly(9,9-dioctylfluorene-co-N-(4-butylphenyl)diphenylamine) (TFB), are primarily utilized as hole-

transporting layers (HTLs) in various organic electronic devices. The butyl group enhances the solubility of the polymer, facilitating solution-based processing techniques which are crucial for large-area and low-cost device fabrication. The triphenylamine moiety provides the necessary electronic properties for efficient hole transport.

## Organic Field-Effect Transistors (OFETs)

In OFETs, polymers containing the 4-butyltriphenylamine unit serve as the active semiconductor layer. The performance of these devices is critically dependent on the charge carrier mobility of the material.

Polymer	Hole Mobility (cm <sup>2</sup> /Vs)	HOMO Level (eV)	LUMO Level (eV)	Reference
Poly(9,9-dioctylfluorene-co-N-(4-butylphenyl)diphenylamine) (TFB)	2 x 10 <sup>-3</sup>	5.3	2.3	[1][2]

Table 1: Key performance metrics of a representative polymer derived from a **1-butyl-4-iodobenzene** precursor.

The relatively high hole mobility and suitable energy levels of TFB make it an effective material for p-channel OFETs.[1][2]

## Organic Light-Emitting Diodes (OLEDs)

In OLEDs, these polymers function as a hole-injection or hole-transport layer, facilitating the efficient injection of holes from the anode and their transport to the emissive layer. This leads to improved device efficiency and stability. The electron-blocking properties of TFB also help to confine electrons within the emissive layer, further enhancing the recombination efficiency.[3]

## Organic Photovoltaics (OPVs)

In OPVs, polymers derived from **1-butyl-4-iodobenzene** can be used as the donor material in the active layer of a bulk heterojunction solar cell. Their HOMO level allows for efficient charge

transfer to a suitable acceptor material.

## Visualizing the Core Processes

To better understand the synthesis and application of these materials, the following diagrams illustrate the key workflows and relationships.

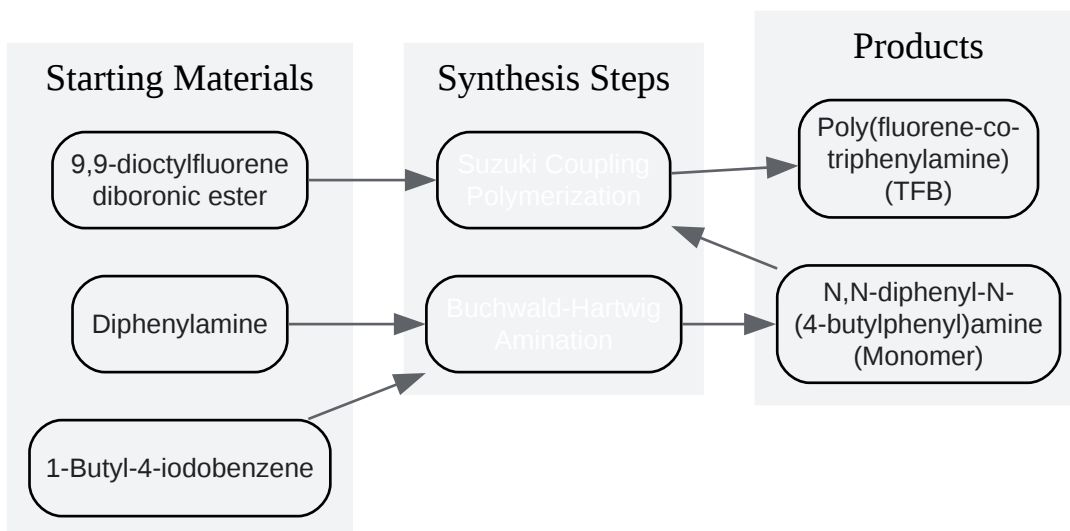

[Click to download full resolution via product page](#)

*Synthetic pathway from **1-Butyl-4-iodobenzene** to a hole-transporting copolymer.*

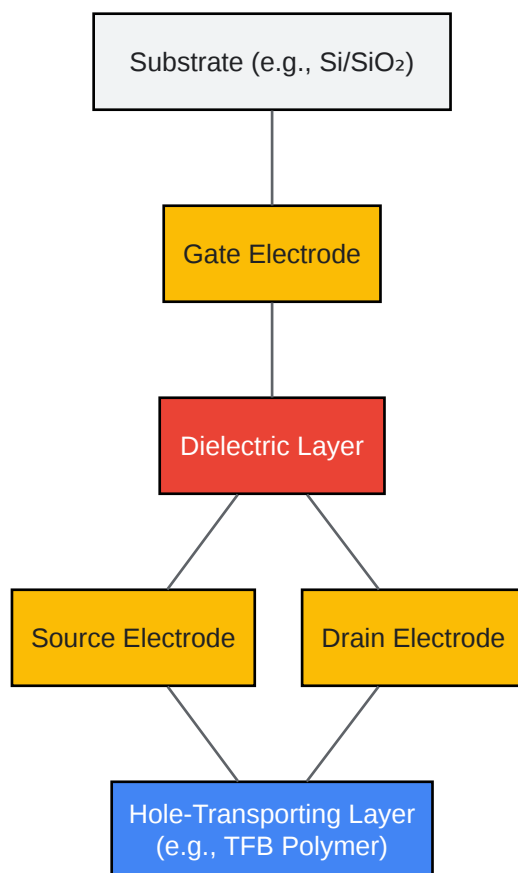

[Click to download full resolution via product page](#)

*Typical bottom-gate, top-contact OFET device architecture utilizing a TFB polymer.*

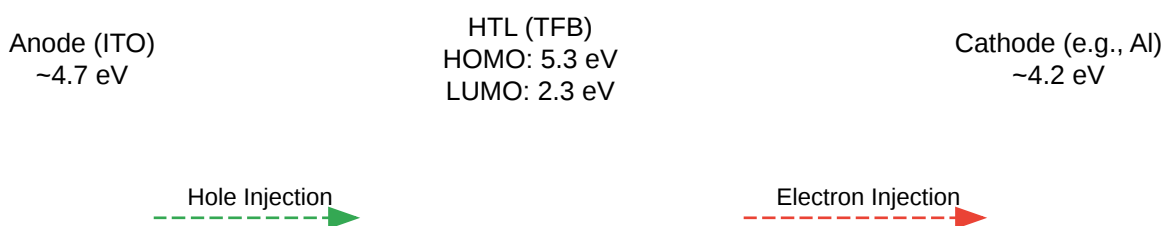

[Click to download full resolution via product page](#)

*Energy level diagram for a device incorporating a TFB polymer as the HTL.*

## Conclusion

**1-Butyl-4-iodobenzene** is a valuable and versatile building block for the synthesis of high-performance hole-transporting polymers used in a variety of organic electronic devices. The incorporation of the butylphenyl-diphenylamine moiety, derived from **1-butyl-4-iodobenzene**,

into polymer backbones imparts desirable properties such as good solubility, high hole mobility, and appropriate energy levels for efficient charge injection and transport. As research in organic electronics continues to advance, the demand for well-defined and functionalized monomers like **1-butyl-4-iodobenzene** is expected to grow, paving the way for the development of next-generation flexible and low-cost electronic applications.

### Need Custom Synthesis?

BenchChem offers custom synthesis for rare earth carbides and specific isotopic labeling.

Email: [info@benchchem.com](mailto:info@benchchem.com) or [Request Quote Online](#).

## References

- 1. Poly(9,9-dioctylfluorene-co-N-(4-butylphenyl)diphenylamine) Three Chongqing Chemdad Co. , Ltd [chemdad.com]
- 2. Poly(9,9-dioctylfluorene-co-N-(4-butylphenyl)diphenylamine) | 220797-16-0 [chemicalbook.com]
- 3. nbinno.com [nbinno.com]
- To cite this document: BenchChem. [The Pivotal Role of 1-Butyl-4-iodobenzene in Advancing Organic Electronics]. BenchChem, [2025]. [Online PDF]. Available at: [https://www.benchchem.com/product/b1271667#1-butyl-4-iodobenzene-applications-in-organic-electronics]

---

### Disclaimer & Data Validity:

The information provided in this document is for Research Use Only (RUO) and is strictly not intended for diagnostic or therapeutic procedures. While BenchChem strives to provide accurate protocols, we make no warranties, express or implied, regarding the fitness of this product for every specific experimental setup.

**Technical Support:** The protocols provided are for reference purposes. Unsure if this reagent suits your experiment? [[Contact our Ph.D. Support Team for a compatibility check](#)]

**Need Industrial/Bulk Grade?** [Request Custom Synthesis Quote](#)

# BenchChem

Our mission is to be the trusted global source of essential and advanced chemicals, empowering scientists and researchers to drive progress in science and industry.

## Contact

Address: 3281 E Guasti Rd

Ontario, CA 91761, United States

Phone: (601) 213-4426

Email: [info@benchchem.com](mailto:info@benchchem.com)