

An In-depth Technical Guide to (-)-cis-2-Benzylaminocyclohexanemethanol: Properties, Synthesis, and Applications

Author: BenchChem Technical Support Team. **Date:** May 2026

Compound of Interest

Compound Name:	(-)-cis-2-Benzylaminocyclohexanemethanol
CAS No.:	71581-93-6
Cat. No.:	B1270552

[Get Quote](#)

This guide provides a comprehensive technical overview of **(-)-cis-2-Benzylaminocyclohexanemethanol**, a chiral amino alcohol with significant applications in asymmetric synthesis and as a building block in the development of complex molecules. This document is intended for researchers, scientists, and professionals in the fields of organic chemistry, medicinal chemistry, and drug development.

Introduction: The Significance of Chiral 1,2-Amino Alcohols

(-)-cis-2-Benzylaminocyclohexanemethanol, also known as (-)-N-Benzyl-cis-2-hydroxymethylcyclohexylamine, belongs to the class of chiral 1,2-amino alcohols. This structural motif is of paramount importance in modern organic synthesis and medicinal chemistry. The presence of two vicinal stereocenters, coupled with the coordinating ability of the amino and hydroxyl groups, makes these molecules highly effective as chiral ligands and auxiliaries in a wide array of stereoselective transformations. The "cis" configuration of the

substituents on the cyclohexane ring enforces a specific spatial arrangement, which is crucial for achieving high levels of stereocontrol in catalyzed reactions. Understanding the physicochemical properties, synthesis, and reactivity of this compound is therefore essential for its effective utilization in the laboratory and in the development of new chemical entities.

Physicochemical and Spectroscopic Properties

A thorough understanding of the physical and chemical properties of a compound is the foundation for its successful application. The key properties of **(-)-cis-2-Benzylaminocyclohexanemethanol** are summarized in the table below.

Property	Value	Source(s)
Molecular Formula	C ₁₄ H ₂₁ NO	[1]
Molecular Weight	219.32 g/mol	[1]
Appearance	White to light yellow crystalline powder	[2]
Melting Point	67-69 °C	[1]
Optical Rotation ([α] ₂₀ /D, c=1 in methanol)	-24°	[1]
Purity	>98.0%	[2]
CAS Number	71581-93-6	[1]

Spectroscopic Data:

Spectroscopic techniques are indispensable for the structural elucidation and purity assessment of organic compounds.

- Nuclear Magnetic Resonance (NMR) Spectroscopy: ¹H and ¹³C NMR spectroscopy are used to confirm the molecular structure of **(-)-cis-2-Benzylaminocyclohexanemethanol**. The proton NMR spectrum will show characteristic signals for the aromatic protons of the benzyl group, the methine and methylene protons of the cyclohexane ring, and the protons of the hydroxymethyl and amino groups.

- Infrared (IR) Spectroscopy: The IR spectrum provides information about the functional groups present in the molecule. Key absorptions are expected for the O-H stretch of the alcohol, the N-H stretch of the secondary amine, C-H stretches of the aromatic and aliphatic portions, and C-N and C-O stretching vibrations.
- Mass Spectrometry (MS): Mass spectrometry is used to determine the molecular weight and fragmentation pattern of the compound, further confirming its identity.

Synthesis of (-)-cis-2-Benzylaminocyclohexanemethanol

The enantioselective synthesis of chiral 1,2-amino alcohols is a well-established field in organic chemistry. While a specific, detailed, step-by-step protocol for the synthesis of **(-)-cis-2-Benzylaminocyclohexanemethanol** is not readily available in peer-reviewed literature, a highly plausible and effective route is through the reductive amination of a suitable keto-alcohol precursor. The following is an adapted, expert-devised protocol based on established methodologies for similar transformations.[3][4]

Proposed Synthetic Pathway: Diastereoselective Reduction and Reductive Amination

The synthesis can be envisioned in two key steps starting from commercially available materials. The rationale is to first establish the cis-relationship between the hydroxyl and the subsequent amino group.

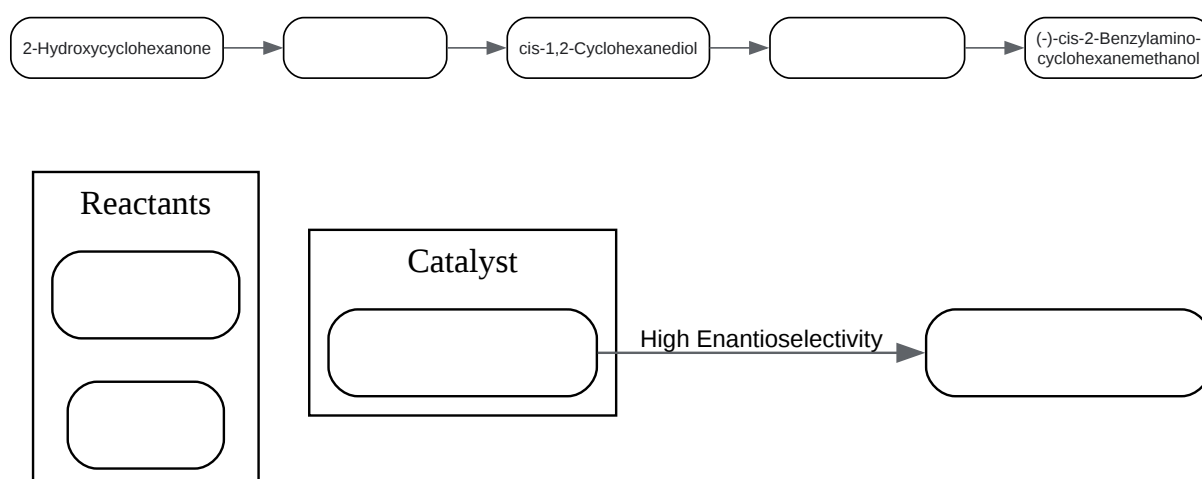

[Click to download full resolution via product page](#)

Need Custom Synthesis?

BenchChem offers custom synthesis for rare earth carbides and specific isotopic labeling.

Email: info@benchchem.com or [Request Quote Online](#).

Sources

- [1. sigmaaldrich.com](https://www.sigmaaldrich.com) [[sigmaaldrich.com](https://www.sigmaaldrich.com)]
- [2. d-nb.info](https://www.d-nb.info) [[d-nb.info](https://www.d-nb.info)]
- [3. researchgate.net](https://www.researchgate.net) [[researchgate.net](https://www.researchgate.net)]
- [4. researchgate.net](https://www.researchgate.net) [[researchgate.net](https://www.researchgate.net)]
- To cite this document: BenchChem. [An In-depth Technical Guide to (-)-cis-2-Benzylaminocyclohexanemethanol: Properties, Synthesis, and Applications]. BenchChem, [2026]. [Online PDF]. Available at: [<https://www.benchchem.com/product/b1270552/docs#an-in-depth-technical-guide-to-cis-2-benzylaminocyclohexanemethanol-properties-synthesis-and-applications>]

Disclaimer & Data Validity:

The information provided in this document is for Research Use Only (RUO) and is strictly not intended for diagnostic or therapeutic procedures. While BenchChem strives to provide accurate protocols, we make no warranties, express or implied, regarding the fitness of this product for every specific experimental setup.

Technical Support: The protocols provided are for reference purposes. Unsure if this reagent suits your experiment?

Need Industrial/Bulk Grade? [Request Custom Synthesis Quote](#)

BenchChem

Our mission is to be the trusted global source of essential and advanced chemicals, empowering scientists and researchers to drive progress in science and industry.

Contact

Address: 3281 E Guasti Rd

Ontario, CA 91761, United States

Phone: (601) 213-4426

Email: info@benchchem.com

[Contact our Ph.D. Support Team for a compatibility check](#)